

OPERATION MANUAL

EN | Original

MZO 200

FROM PRODUCTION 2021

EDITIN 11.2022

REFERENCE NUMBER MZO-200-AGCO_BA_21_EN_2022-11

Machine identification

In order for your dealer to assist you as efficiently as possible, you will need to provide some information about your machine. Please enter the information here.

Designation

Working width

Weight

Machine number

Additional equipment

Dealer's address

Manufacturer's address

Müthing GmbH & Co. KG Soest
Am Silberg 23
59494 Soest
Germany

Handover declaration

- Fill out this sheet with your dealer.
- Then separate this sheet from the operating manual and send it to the manufacturer within 10 days of delivery. Only in this way will the guarantee be effective from the date of delivery

To
Müthing Gmbh & Co. KG Soest
Am Silberg 23
59494 Soest
Germany

I have bought the machine described below from Müthing GmbH & Co. KG Soest, and confirm full delivery and handover of the machine including the operating manual and spare parts list, as well as training in operating the devices with safety instructions and warning information from your dealer.

I confirm additionally that I have read and understood the operating manual and am in agreement with the information contained therein. This applies in particular to the chapter Safety.

Client

Name		First name	
Address			
Post code		Town/city	
Telephone		Fax	
E-mail		Date	

Machine

Machine	MU-	Serial number	
Working width		Gear-box	
Rigid mounting		Non-rigid mounting	
Year of construction		Delivery date	
Delivered by			

Signature of client

Signature and stamp of sales partner

Handover declaration

Handover declaration – Copy

– This sheet remains with the client in the operating manual

I have bought the machine described below from Müthing GmbH & Co. KG Soest, and confirm full delivery and handover of the machine including the operating manual and spare parts list, as well as training in operating the devices with safety instructions and warning information from your dealer.

I confirm additionally that I have read and understood the operating manual and am in agreement with the information contained therein. This applies in particular to the chapter Safety.

Client

Name		First name	
Address			
Post code		Town/city	
Telephone		Fax	
E-mail		Date	

Machine

Machine	MU-	Serial number	
Working width		Gear-box	
Rigid mounting		Non-rigid mounting	
Year of construction		Delivery date	
Delivered by			

Signature of client

Signature and stamp of sales partner



Table of Contents

Handover declaration	3	Parking and storage	33
Handover declaration – Copy	5	Setting down the machine in a secure position	33
About this operating manual	8	Storing the machine	35
Target group	8	Maintenance	36
Safety	8	For your safety	36
Instruction	8	General information	37
Other applicable documents	8	Working on the baler	39
Symbols	9	Maintenance intervals and setting work	42
Safety	10	Lubricating work	43
For your safety	10	PTO shaft	45
Warning signs	10	Transmission oil	47
Definitions	13	Chopping blades	48
Who is allowed to operate the machine?	13	V-belt	49
Assembly	13	Fault elimination	50
Putting the machine into operation	13	Disposal of the machine	52
Care and maintenance	15	EC Declaration of Incorporation	53
Further regulations	16	In accordance with the EC Directive 2006/42/EG	53
Familiarising yourself with the machine ..	17	UK Declaration of Incorporation	54
Range of application of the machine	17	UKCA	54
Features of the machine	18	Index	55
Designation of components	19		
Technical specifications	20		
Delivery and assembly	21		
Checking the scope of delivery	21		
Coupling the machine	22		
Prerequisites	22		
Chopper	22		
PTO shaft	23		
Hydraulics	24		
Preparation	25		
Working width	25		
Press wheel	26		
Shear bars	26		
Guide plates	27		
Driving on the road	28		
Transport without coupling	28		
Chopping	29		
Tips	29		
Work position	29		
Task	30		
Cleaning and care	32		
Cleaning	32		
Care	32		

About this operating manual

Target group

This operating manual is intended for trained machine operators and persons who are otherwise qualified to carry out landscape work and who have received training in how to use this machine.

Safety

Familiarise yourself with the contents of this operating manual which are relevant for your activity before commissioning or assembling the machine. Always read through the safety instructions in the chapter "Safety" and observe the warning information in the individual chapters. In this way, you will achieve optimum work results and operational safety.

For the employer

Staff must be instructed in the safe handling of the machine before the initial commissioning. Untrained or unauthorised persons are not permitted to use the machine.

The following are included in this training:

- Checking that staff possess the necessary requirements for safely handling the machine.
- Handing out the operating manual and the other relevant and applicable documents or an intensive course of training which, in particular, includes the safe handling of the machine.

Regular instruction sessions

Instruct your staff regularly, but at least once a year, concerning the basic procedural measures for safely handling the machine.

Instruction

You will receive training from your dealership concerning using the controls, safe operation and care of the machine. Commissioning without first receiving training is not permitted.

Other applicable documents

In addition to the operating manual, other documents also form an integral part of the machine:

EC Declaration of Incorporation	Integral part of this operating manual → Chapter »EC Declaration of Incorporation«, Page 53
List of approved balers	Integral part of the delivery with this machine
Certification by the authorised specialist workshop that the machine has been correctly fitted	Integral part of the delivery with this machine
Spare parts list	Integral part of the delivery with this machine
PTO shaft operating manual	Integral part of the delivery with this machine

About this operating manual

Symbols

In order to make this manual clear and easy to read, we have used various symbols. They are explained below:

- A bullet point accompanies each item in a list
- ▶ A triangle indicates operating functions which must be performed
- An arrow indicates a cross-reference to other sections of this manual
- [+] A plus sign indicates an accessory that is not included in the standard version.

Pictograms

We have also used pictograms to help you find instructions more quickly:



The warning triangle indicates warning information. Failure to observe these safety instructions can result in:

- Moderate to serious injury
- Fatal injury

You will find the warning information associated with individual operations, where it is important to observe the warning information before these operations are carried out.

You will also find safety instructions in the chapter »Safety« which cannot be assigned to any particular operations, but increase your ability to work safely in different situations.



This sign indicates important instructions regarding the machine. Failure to observe these safety instructions can result in:

- Serious faults in the correct operation of the machine.
- Damage to the machine



This symbol indicates information, tips and instructions about operation.



This symbol indicates tips for assembly or adjustment work.



This symbol indicates examples that help you to understand the instructions better.

Parts in the text which refer to individual machines or to conditions have a colored background. After the colored section, the text then applies again to all machines. For example:

Only for machines with a pneumatic brake system

- ▶ Connect brake hoses
- ▶ Connect hydraulic hoses

Safety

For your safety

This chapter contains general safety instructions. Each chapter of the operating manual contains additional warning instructions which are not described here. Observe the safety instructions:

- In the interest of your own safety,
- In the interest of the safety of others
- To ensure the safety of the machine

Numerous risks can result from handling landscaping machines the wrong way. Therefore, always work with particular care and never under time pressure.

For the employer

Inform personnel working with the machine of these safety instructions at regular intervals and according to statutory regulations.

Warning signs

On the machine you will find labels that serve to ensure your safety. The labels must not be removed. If labels become illegible or begin to peel off, new labels can be ordered and attached in the appropriate places.

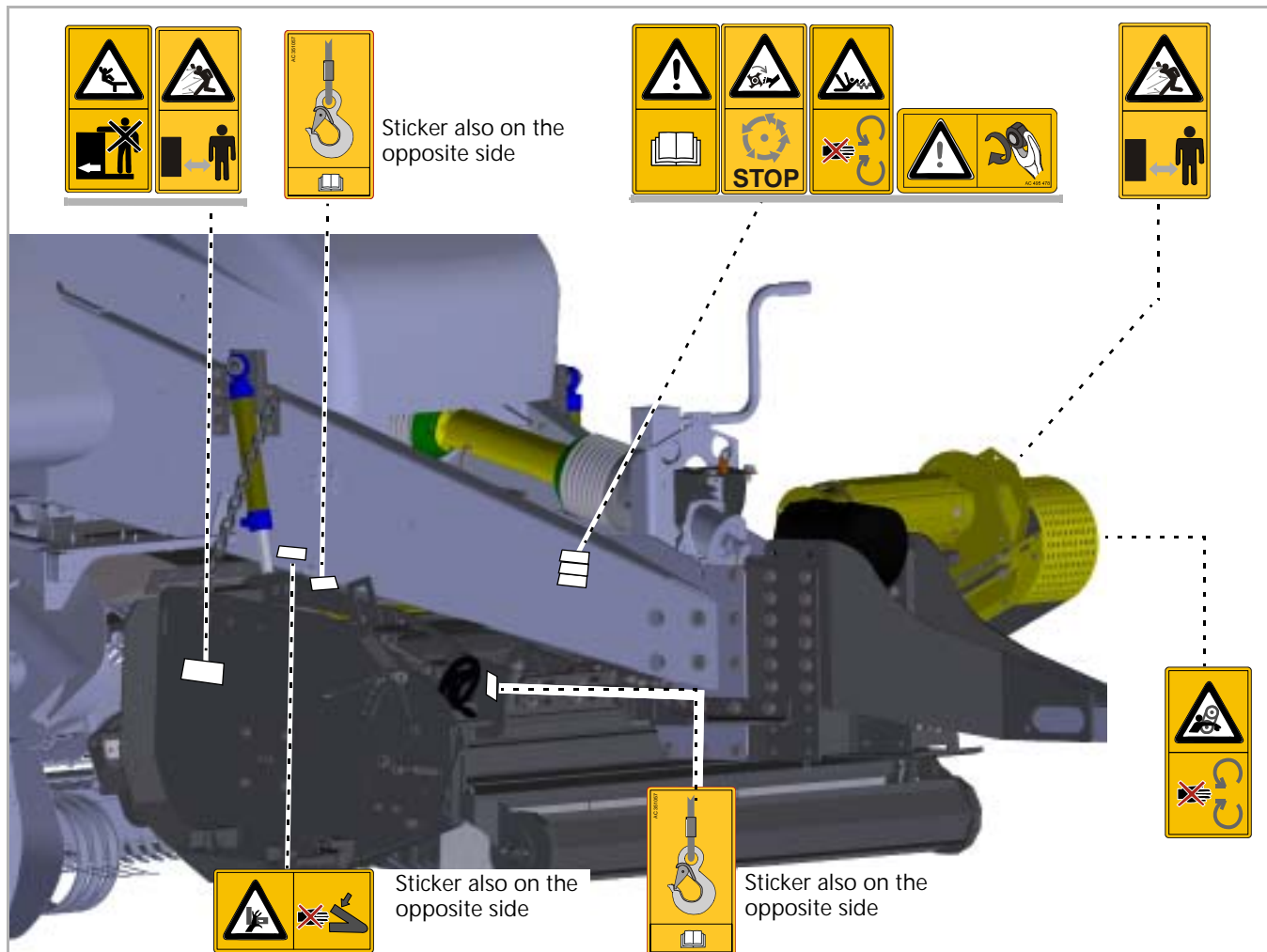

Meaning of warning signs



Read the operating manual carefully and follow the instructions
Commissioning of the machine must not take place before the operating manual has been read and understood. This particularly applies to safety instructions.



Riding on the machine is prohibited
It can result in serious or even fatal injury.



Do not remove protective devices
Never open or remove the protective devices while the tractor's engine is running. Never operate the machine without the protective device.



Be aware of the danger of being pulled in
There is a danger of being pulled into the PTO shaft in the event of inappropriate use.



Shackles
Only raise the machine using loading equipment at the points indicated.



Rotating and trailing machine parts
Only approach the machine when all machine parts have stopped moving.



Danger of objects being thrown out

During operation, there is a danger of objects such as stones being picked up and thrown out by the machine. Ensure that no persons are present in the hazard area.



Retighten screws

After the first hours of operation, and as required, all screws must be checked and tightened if necessary. Vibrations might have loosened the screwed connections.



Caution, risk of crushing

Avoid the hazard area. Gaps between components may become smaller or disappear completely.

Definitions

All direction information is given in relation to the direction of travel of the machine:

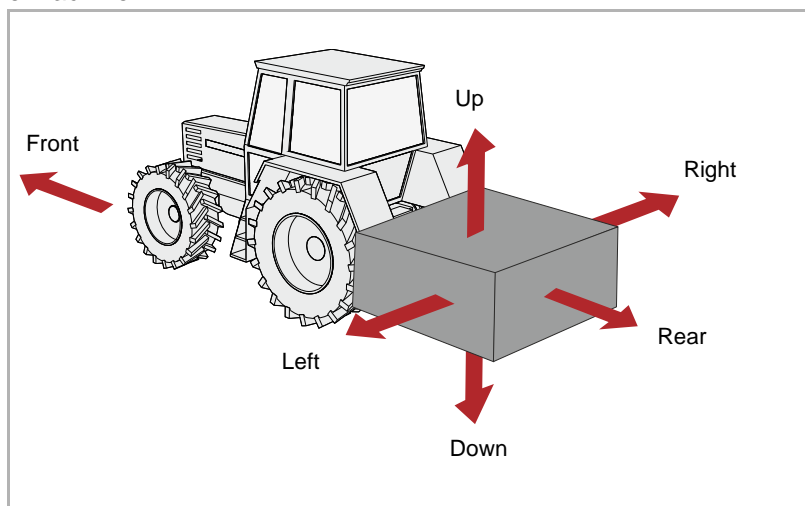

Who is allowed to operate the machine?

Only qualified personnel

Only qualified persons who have been informed of the dangers associated with handling the machine are permitted to operate, service or repair the machine. As a rule, such persons are trained and experienced in agricultural work or have been thoroughly trained in a similar fashion.

Assembly

Authorised specialist workshop

Only an authorised specialist workshop must fit the machine to an approved baler. The specialist workshop will issue a certificate to confirm that the machine has been fitted correctly. The machine must not be started up if an installation certificate has not been issued.

Failure to observe these instructions can result in serious or fatal injury.

Putting the machine into operation

Training required before commissioning

The machine must not be put into operation until the user has been given proper training by an employee of the dealer, a factory representative, or an employee of the manufacturer. Commissioning without training can lead to damage to the machine due to false operation or accidents can happen.

Ensure that the machine is in perfect working condition

Do not operate the machine unless it is in perfect working condition. Check all important components and replace any defective components before starting the machine. Defective components can cause damage to equipment and personal injury.

Do not remove the protective equipment

The protective equipment must not be removed or by-passed. Check all protective equipment before starting the machine. Unprotected machine parts can cause serious or fatal injury.

Riding on the machine is strictly prohibited

People or objects must never be transported on the machine. Riding on the machine poses a risk to life and limb and is strictly prohibited.

Height of the machine and overhead power lines

If a height of 4.00 m is exceeded when folding the machine in and out, the machine must not be folded in the vicinity of live overhead power lines. Danger of electrocution! Should the machine come into contact with a live overhead power line:

- Do not attempt to exit the tractor cabin
- Do not touch any metal parts on the tractor
- Do not create any conductive contact with the ground
- Warn all persons in the area not to approach the tractor or the machine
- Wait for help from professional emergency service personnel as power in the live overhead power line must first be switched off

Never climb onto the machine beneath live overhead power lines. The voltage can jump across even if the lines are not actually touching the machine.

Check the hazard area

Before driving off, folding out, and operating the machine and during operation, check its hazard area. Make sure that you have an adequate view. Do not begin work until the hazard area is cleared of any persons or objects. Information regarding the hazard area can be found in the corresponding chapter.

→ Chapter »Chopping«, Section »Task«, Page 30.

Parts could be ejected from the machine at high speed in certain circumstances. The hazard area, particularly in front of and behind the machine, must be cleared of any persons, animals or objects before starting.

Any use of the machine without verification of the hazard area can lead to serious or fatal accidents.

Retighten all nuts, bolts and screws

Nuts, bolts and screws should be checked at regular intervals and tightened if necessary. Screws can come loose unnoticed while operating. Damage to the machine or accidents may be caused as a result.

What to do in the event of a fault

In the event of a malfunction, shut down and secure the machine immediately. The fault may be eliminated immediately, or a specialist workshop must be assigned the task. Further operation of the machine can lead to damage to the machine or injury to persons.

Care and maintenance

Observe the care and maintenance intervals

Observe prescribed intervals for maintenance checks and inspections specified in the operating manual. If these periods are not observed, this can lead to damage to the machine, poor quality of work or accidents.

Use original replacement parts

Many components have special properties that are essential for the stability and correct operation of the machine. Unsuitable spare parts or accessory parts or incorrectly performed repairs or changes can cause damage to the machine, accidents or serious injury.

Müthing strongly recommends using only approved original Müthing accessories and spare parts. Müthing can guarantee the safety, reliability and suitability of these parts only.

Use of non-original Müthing spare parts shall invalidate any warranty claims.

When performing any care and maintenance work:

- Switch off the PTO stub shaft
- Depressurise the hydraulic system
- Park the tractor safely, switch off the engine
- Secure the tractor against being started up by third parties
- Make sure the machine is standing securely. Provide additional support as required
- Do not use parts of the machine as climbing aids; use only secure steps, ladders or other means of access
- Secure the machine against rolling away
- Never reach into the V-belt while it is moving

It is only possible to guarantee work safety during care or maintenance work through observing these regulations.

Turn off the electrical supply

Prior to carrying out work on the electrical system, disconnect the system from the power supply. Systems supplied with electrical power can cause damage to equipment and personal injury.

Replace hydraulic hoses

Replace hydraulic hoses every six years. Hydraulic hoses can age without any externally visible damage. Defect hydraulic lines can lead to severe or fatal injuries.

Caution when cleaning with a high-pressure cleaner

The machine can be cleaned using either water or a steam jet. Only use a low pressure to clean bearings, fans, signal mixer units, plastic parts and hydraulic hoses. Excessively high pressures can cause damage to these parts.

Before carrying out welding work, disconnect the battery and alternator

Before carrying out any electric welding work on the attached machine, disconnect the tractor battery and the alternator. This avoids damage to the electrical system.

Tighten all screwed connections

All screw connections that are released during maintenance and repair work must now be retightened. Loose screwed connections can cause bolts to undo without you noticing during your work. As a result, machine parts can become detached. Otherwise, this may result in severe injury or damage to equipment.

Further regulations

Observe the regulations

In addition to these safety instructions, observe the following:

- Accident prevention regulations
- Generally recognised safety regulations, occupational health requirements and road traffic regulations
- Information and instructions in this operating manual
- Operation, maintenance and repair instructions

Familiarising yourself with the machine

This chapter contains general information on your machine as well as information on:

- Range of application
- Features
- Designation of components
- Technical specifications

Range of application of the machine

The machine may only be used for its intended agricultural or associated purpose in conjunction with an approved baler.

Tool	Purpose
M chopping blade	Chopping straw, hay, grass that has started to dry out or other vegetation of a similar consistency, which has been deposited in swaths.

Since the conditions of use are very varied, the user must pay particular attention to the machine's performance limits. The machine must be switched off immediately if there is any indication of overstress.

Proper use

The machine should only be used for the designated work as described in this operating manual. Any application other than or beyond this is considered improper use.

Examples of improper use:

- Transporting persons or objects
 - Cutting of any products other than those specified or those of a similar nature
- »Range of application of the machine«
- Transferring power to other objects
 - Fitting to balers that have not been approved. A list of the approved balers is provided with the machine and is an integral part of the delivery of the machine
 - Working widths under 250 mm ground clearance
 - Any type of ground work
 - Use of the machine in a position in which the tools do not point towards the ground, for example in a vertical position

The manufacturer and dealers are not liable for damage caused by improper use. The risk is borne solely by the user.

Familiarising yourself with the machine

Features of the machine

Robust housing in optimised form

The housing is particularly robust for heavy use and is designed in an optimised form.

Power transmission

Power is transmitted to a gear box via a PTO shaft. From there, the V-belt is driven by another PTO shaft.

Safety

The machine is constructed in accordance with EU and GB regulations, for maximum possible safety of operation.

Familiarising yourself with the machine

Designation of components

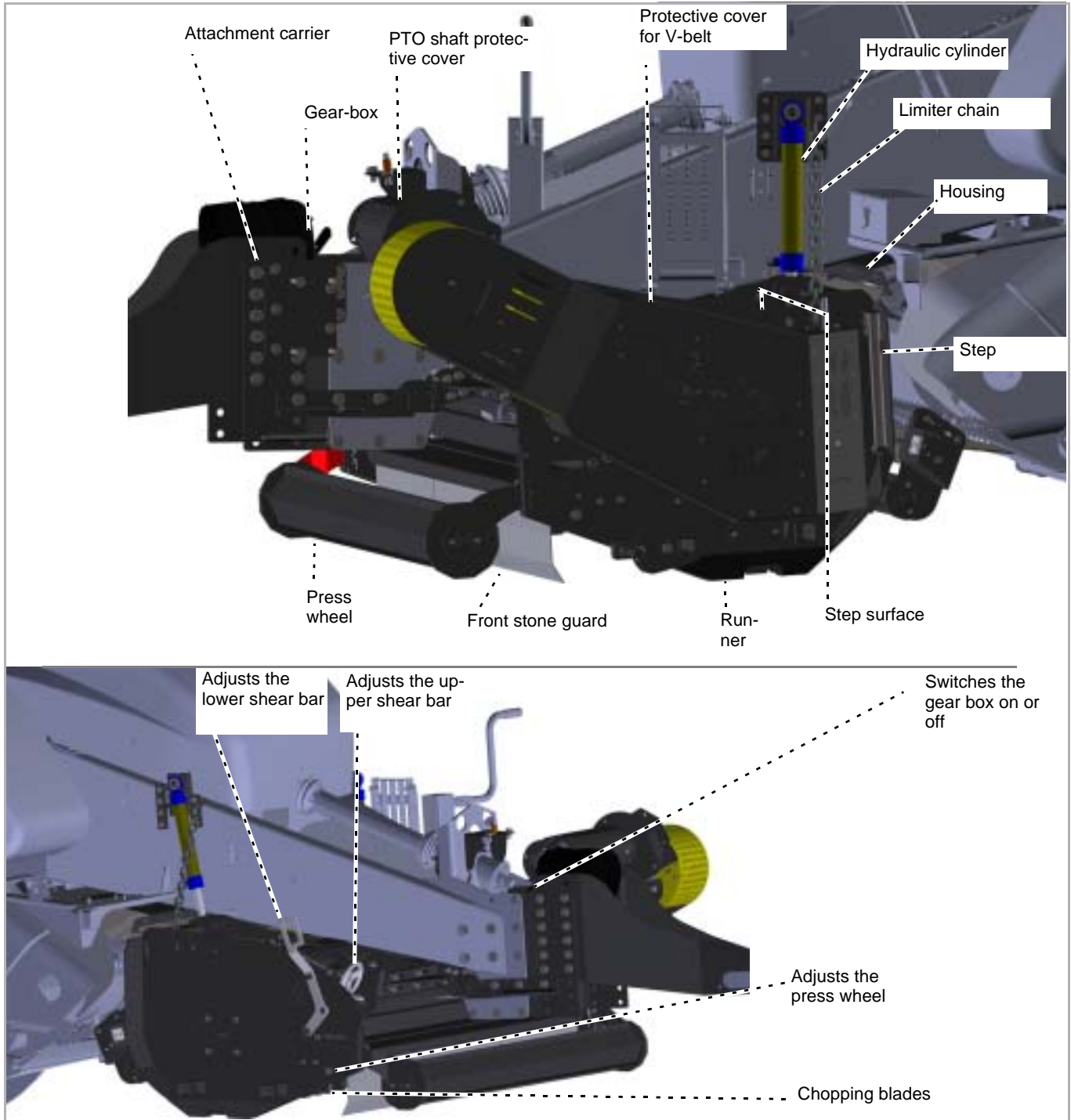

Familiarising yourself with the machine

Technical specifications

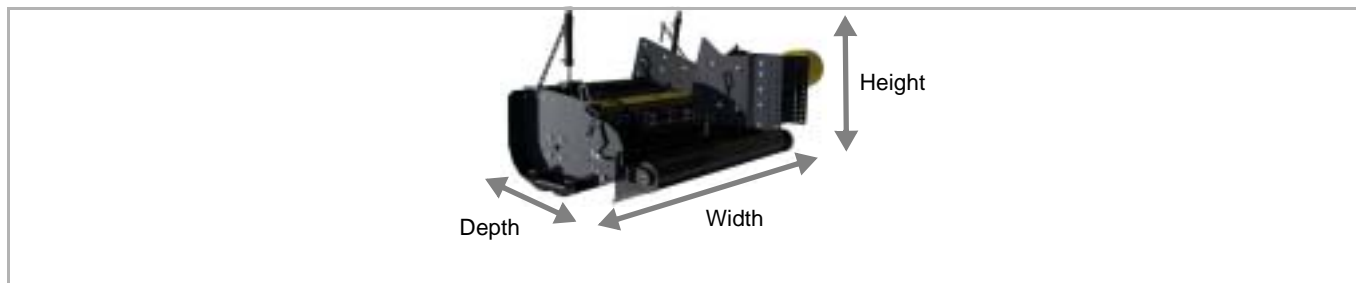

		MZO 200
Height [m]		
Uncoupled		1.20
Width [m]		
Machine width		2.50
Working width		2.00
Depth [m]		
In transport position		1,56
Total weight [kg]		
Depending on equipment level, approx.		850
Rotational speed of rotor [rpm]		
PTO stub shaft 1000 rpm		3000
Power requirement [kW]		
Minimum		80
Maximum permitted		150
Working depth [mm]		
Minimum above ground		250
Maximum above ground		500
PTO shaft		
Model		GE 2400 MZO
Number of tools		
Chopping blades, depending on the rotor		44 / 88
Lubricants		
Gear-box oil, fully synthetic		SAE 75/90
Noise emission [dB(A)]		
In the workplace		< 80
Paint colors		
Yellow		RAL 1007
Black		RAL 9005

Checking the scope of delivery

The machine is delivered completely assembled. If parts of the machine have not been assembled, please contact your dealer.



Do not assemble the machine yourself

Do not perform assembly work yourself since requirements for an orderly condition of the machine are :

- Observance of a sequence of worksteps
- Compliance with tolerances and torques
- Certification of the specialist workshop by the manufacturer

If parts have not been fitted to the machine correctly, this may result in accidents or in serious or fatal injury.



If parts are missing or have been damaged during transportation, please submit a claim immediately to your dealer, importer or the manufacturer.

Coupling the machine

Prerequisites

The baler has been prepared by an authorised specialist workshop so that the chopper can be fitted. You can check that the requirements have been fulfilled:

- You are in possession of a certificate issued by the authorised specialist workshop or by the manufacturer with regard to the installation of the chopper
- The baler can be found on the list of approved balers
- The headstock on the baler is prepared for fitting the chopper.

If all the requirements have been fulfilled, you can fit the chopper to the baler.

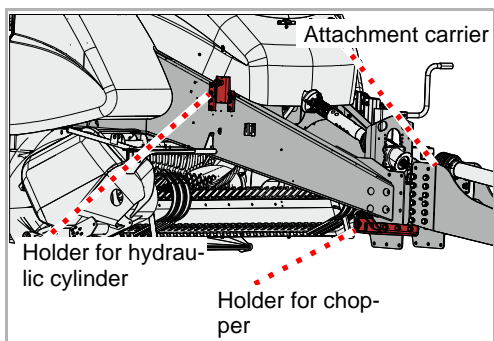

Chopper

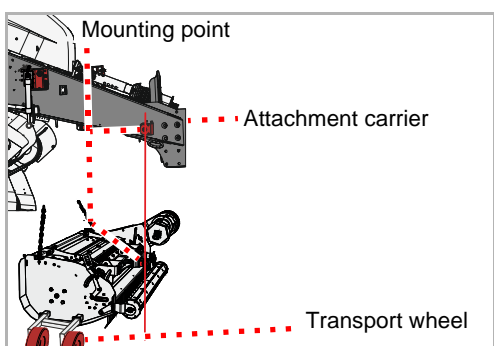

- ▶ Secure the baler against rolling away
 - ▶ Raise the drawbar of the baler over the spindle on the support leg
- Baler operating manual

- ▶ Move the chopper underneath the attachment carrier using the transport wheels. In doing so, the mounting points on the chopper should be lined up with the mounting points on the attachment carrier.

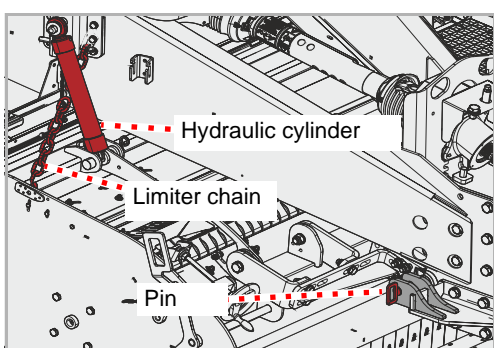

- ▶ Undo the pins on both sides of the attachment carrier
- ▶ Lower the drawbar of the baler over the spindle on the support leg until the mounting points on the attachment carrier coincide with the mounting points on the chopper. If necessary, align the chopper as required.
- ▶ Secure the chopper using the pins on both sides of the attachment carrier

Coupling the machine

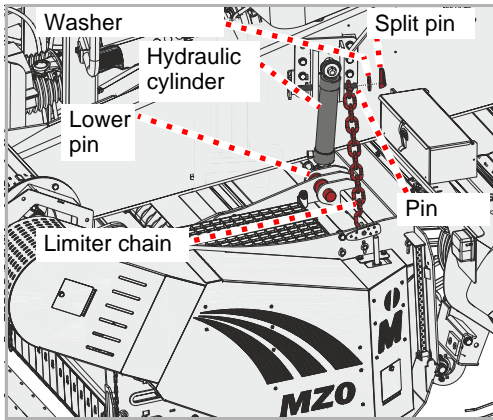

- ▶ Attach the hydraulic cylinder to the lower pin and secure it using a washer and split pin
- ▶ Hook the limiter chain on the pin and secure it using a washer and split pin
- ▶ Also attach the hydraulic cylinder and limiter chain on the other side
- ▶ Raise the baler
- ▶ Remove the transport wheels

PTO shaft

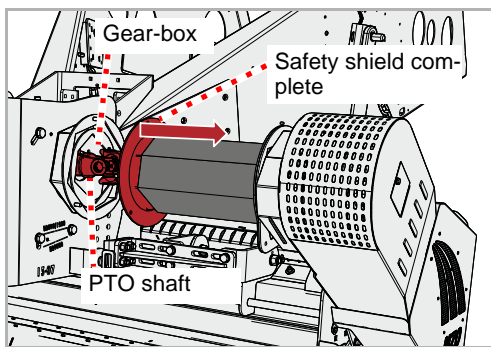

- ▶ Push back the PTO shaft guard and connect the chopper's PTO shaft to the gear box. Make sure that the lock pins engage securely.

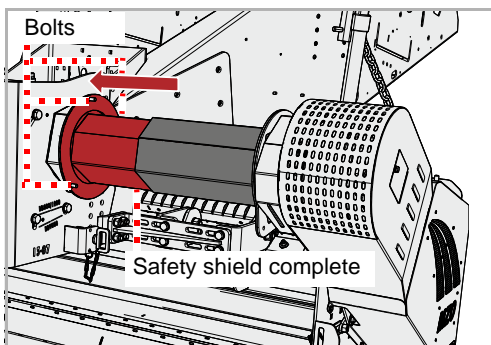

- ▶ Fit the PTO shaft guard and secure it with nuts

Coupling the machine

Hydraulics

The following functions can be controlled:

Function	Color of dust cap
Raising or lowering the machine	Red

- ▶ Connect the hydraulic hose to a single-acting control valve

Working width

The working depth can be adjusted using limiter chains. The optimum working depth is dependent on the swath height.



Tools must not come into contact with the ground

Any contact with the ground could result in stones or other material not being held back safely by the stone guard.

Persons even outside of the hazard area could be injured by ejected material.

Minimum clearance from the ground: 250 mm

The minimum clearance from the ground must not fall below 250 mm during work. If there is a large number of stones on the ground, a clearance of at least 300 mm is necessary.

If the blades come into contact with stones, this may create sparks, which could cause a fire.

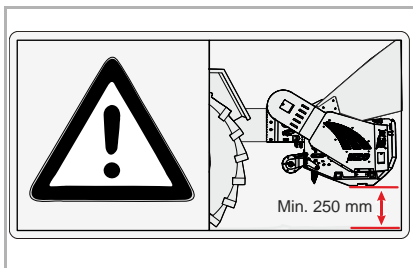

Adjust the limiter chains to the same setting on both sides

For the lowest working depth setting, the limiter chains must be adjusted to the same setting on both sides.

If the limiter chains are adjusted to different settings, the machine may be damaged by excessive wear.

The working depth is adjusted via the control unit on the tractor using the two hydraulic cylinders. The lowest position is set using the limiter chains on both sides of the chopper.

- ▶ Secure the tractor against rolling away
- ▶ Move the baler into its work position
- ▶ Raise the chopper using the tractor's control unit
- ▶ Remove the split pin and washer from the limiter chain
- ▶ For the lowest position, hook the limiter chain on the pin, shortening or lengthening the chain as required, and secure it using a washer and split pin
- ▶ Adjust the chain to the same setting on the other side of the chopper
- ▶ Use the control unit to adjust the working depth as required

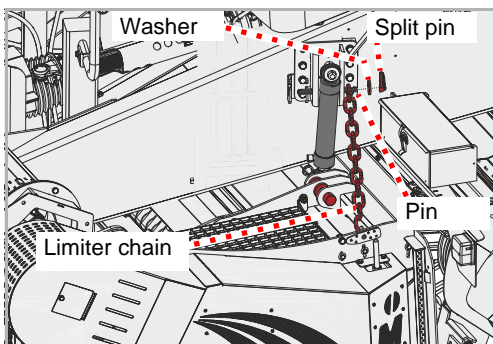

Preparation

Press wheel

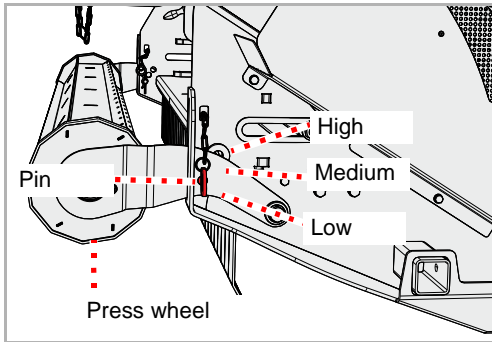

The press wheel can be adjusted depending on the height of the swath.

- ▶ Remove the pins on both sides of the chopper
- ▶ Adjust the press wheel as required and fix it in place using the pins on both sides of the chopper
- ▶ Secure the pin with a split pin

Shear bars

The length of the material to be chopped can be set using an upper and a lower shear bar. This setting is dependent on the characteristics of the material to be chopped. Therefore check the setting later on, when you are in the field.

Lower shear bar

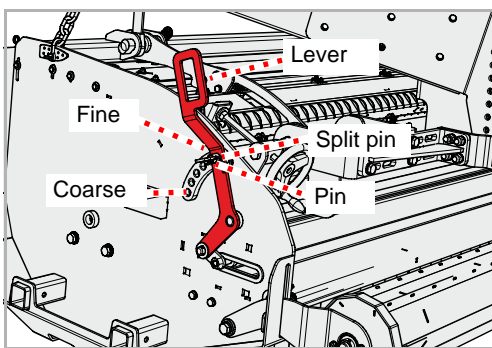

Initially set the lower shear bar to "Coarse".

- ▶ Remove the split pin from the pin
- ▶ Remove the pin
- ▶ Use the lever to adjust the shear bar to the required setting

Upper shear bar

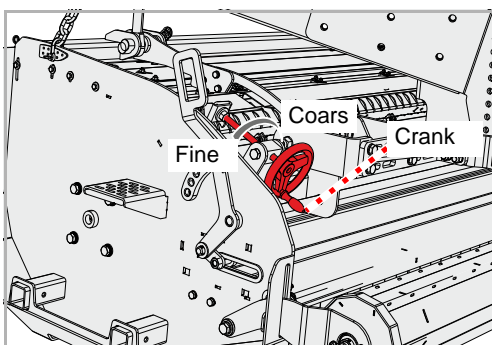

Initially set the upper shear bar to "Coarse". If you required a finer cut, adjust the upper shear bar towards "Fine".

If the upper shear bar is set to the maximum "Fine" setting but you want the material to be chopped to an even shorter length, adjust the setting of the lower shear bar towards "Fine".

- ▶ Use the crank to adjust the shear bar to the required setting

Guide plates

The material flow can be adjusted using the guide plates. This setting is dependent on the characteristics of the material to be chopped:

- The volume of material to be chopped
- The characteristics of the material to be chopped, such as length, dampness and strength
- The required distribution in the bale

Therefore check the setting later on, when you are in the field.

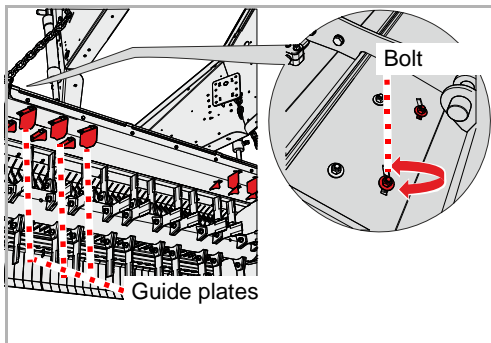

- ▶ Slightly undo the bolt
- ▶ Adjust the position of the guide plate as required
- ▶ Retighten the bolt

Driving on the road

- ▶ Raise the chopper to the upper position using the tractor's control unit
- ▶ Switch off the chopper's gear box

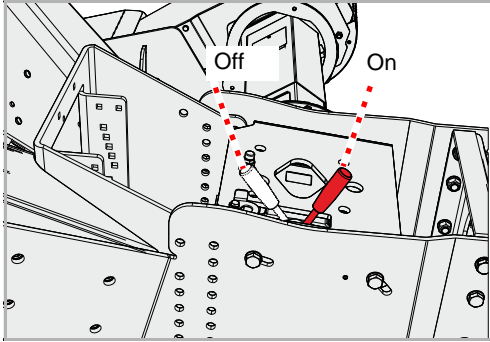

Transport without coupling

The chopper can be removed from the baler for transportation, for example on a trailer. Only use the designated points for attaching the lifting device. The machine must be securely positioned.

- ▶ Setting down the machine in a secure position
→ Chapter »Parking and storage« paragraph »Setting down the machine in a secure position«, page 33

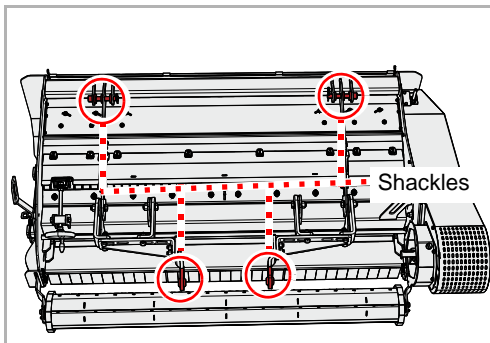

- ▶ Attach suitable lifting devices to the lifting eyes
- ▶ Raise the chopper with suitable lifting gear and position it on the loading bed
- ▶ Secure the chopper here against slipping

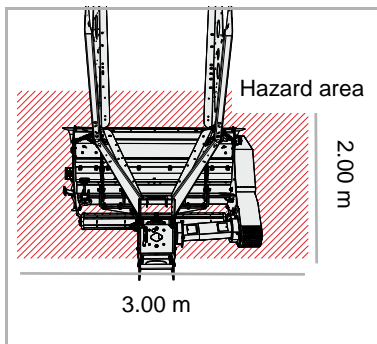

Check the hazard area

Before lowering the machine into the work position, check the hazard area around the machine. Make sure that you have an adequate view. Do not begin to lower the machine into the work position until the hazard area is cleared of any persons or objects.

Lowering the machine without first checking the hazard area may result in serious or fatal accidents.

Tips

Here are a few tips to enable you to achieve the work results you require with your chopper:

- Make sure that the material to be chopped is well dried beforehand. If the material to be chopped is damp, this will make chopping difficult.
- Always switch on the baler's cutting system when using the chopper. This is particularly important when dealing with lodged crop or flat swaths. This prevents an excessive proportion of uncut material in the bale.
- Avoid working with very flat swaths. If the swaths are flat, combine two swaths into a single swath.
- Adjust the speed according to the amount of material to be chopped in the swath. If there is a lot of material to be chopped, drive more slowly, rather than too quickly.
- Once you have come to the end of the swath, continue driving straight ahead until the chopper has reached the end of the swath.

Work position

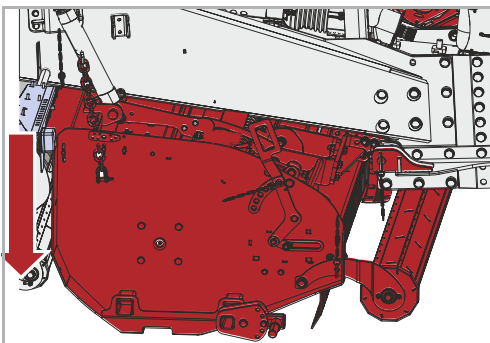

- ▶ Use the tractor's control unit to lower the chopper into the work position

Chopping

Task

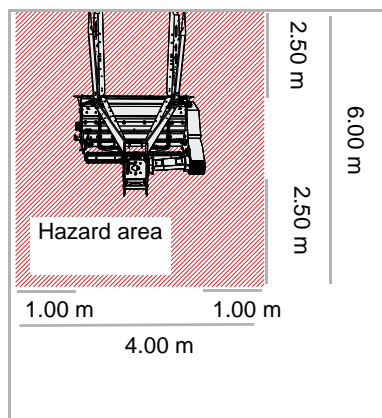

Check the hazard area

The hazard area in front of and behind the machine is 2.50 m, to the sides in each case 1 m. Before driving off, operating the machine and during operation, check its hazard area. Make sure that you have an adequate view. Do not begin work until the hazard area is cleared of any persons or objects.

Parts could be ejected from the machine at high speed in certain circumstances. The hazard area, particularly in front of and behind the machine, must be cleared of any persons, animals or objects before starting.

Any use of the machine without verification of the hazard area can lead to serious or fatal accidents.

Assess the dust exposure levels

If the ground and the material to be mulched are dry, you may be exposed to dust. Dust exposure can be avoided by taking into account the direction of the wind. If dust exposure cannot be avoided, you can protect yourself by wearing a dust mask. If these measures are not sufficient, use a tractor with an enclosed cab and a dust filter.

Dust exposure may lead to respiratory diseases.

Tools must not come into contact with the ground

Any contact with the ground could result in stones or other material not being held back safely by the stone guard.

Persons even outside of the hazard area could be injured by ejected material.

Minimum clearance from the ground: 250 mm

The minimum clearance from the ground must not fall below 250 mm during work. If there is a large number of stones on the ground, a clearance of at least 300 mm is necessary.

If the blades come into contact with stones, this may create sparks, which could cause a fire.

Remove dust and chopping remnants

Dust and chopping remnants accumulate on the chopper and the baler. Clean the chopper and the baler thoroughly of any accumulated debris on a daily basis, or more frequently if dust exposure and outside temperatures are high.

Dust and chopping remnants may catch fire as a result of heat being generated or of flying sparks. This may result in injury or death.



Only work forwards

The machine may only be located in work position when moving forwards. The machine must be raised up when reversing. *A machine in work position when reversing could result in serious damage to the machine.*

Check the chopper if it has come into contact with foreign bodies

If the chopper has come into contact with a foreign body, check the chopper for damage. The rotor and blades must be checked, in particular. Replace any damaged parts immediately.

If the chopper is operated with damaged components still in place, parts of the chopper may be flung out with great force. This may result in injury or death.

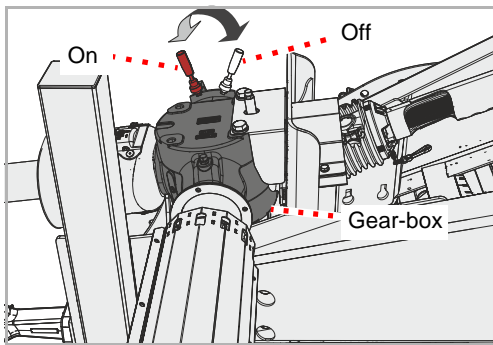

- ▶ Switch on the chopper's gear box
- ▶ Switch on the PTO stub shaft and slowly bring the machine to the rated speed
- ▶ First drive at low speed into the swath, and then slowly increase your driving speed. When doing so, pay attention to the chopper.

If the chopper is working too hard:

- ▶ Reduce speed
- ▶ Drive at a suitable speed. The speed must be adjusted according to the material to be chopped.

Cleaning and care

Cleaning

Daily



Remove dust and chopping remnants

Dust and chopping remnants accumulate on the chopper and the baler. Clean the chopper and the baler thoroughly of any accumulated debris on a daily basis, or more frequently if dust exposure and outside temperatures are high.

Dust and chopping remnants may catch fire as a result of heat being generated or of flying sparks. This may result in injury or death.

A hand brush, for example, can be used to clean the machine.

Once work is finished



Only use low pressure to clean the bearings

Only use low pressure to clean the bearings.

Water penetration reduces the service life of the bearings

A high-pressure cleaner, for example, can be used to clean the machine. Never point the water jet directly at the labels or type plate.

Care

To ensure the machine's long service life, we recommend applying a protective coating of oil after the end of the season and during storage.



Use only approved and biodegradable oil, e.g. rapeseed oil.

Setting down the machine in a secure position



You can set the chopper down:

- Whilst it is fitted to the baler
- Once it has been removed and disconnected from the baler

Ensure that there are no unauthorised persons can enter the set-down location

The set-down location must be selected such that no unauthorised persons can enter.

Persons could be injured by coming into contact with parts of the machine or by manipulating the machine.

Fitted to the baler

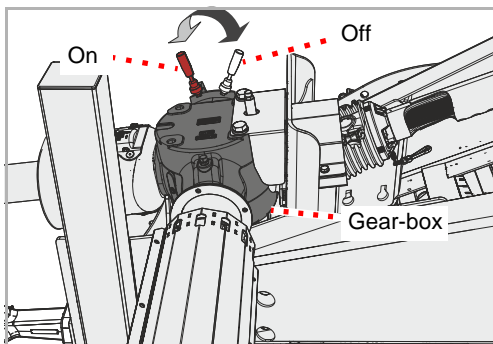

Requirements on the set-down location:

- Protected against access by unauthorised persons, such as children
 - ▶ Lower the chopper to the lower position using the tractor's control unit
 - ▶ Switch off the chopper's gear box
 - ▶ Disconnect the hydraulic hose from the connection to the tractor
 - ▶ Remove the baler from the tractor
- Baler operating manual

Removed from the baler

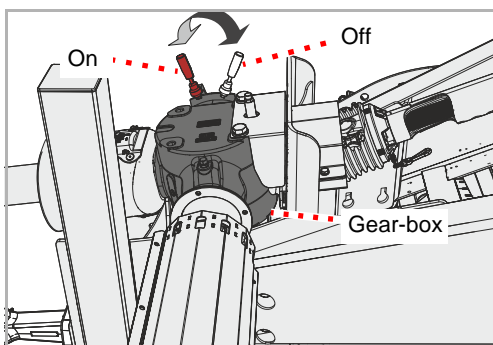

Requirements on the set-down location:

- Horizontal, solid surface
 - Sufficient room on all sides
 - Protected against access by unauthorised persons, such as children
 - ▶ Secure the tractor against rolling away
 - ▶ Lower the chopper to the lower position using the tractor's control unit
 - ▶ Disconnect the hydraulic hose from the connection to the tractor
 - ▶ Switch off the chopper's gear box
 - ▶ Remove the baler from the tractor and secure it against rolling away
- Baler operating manual

Parking and storage

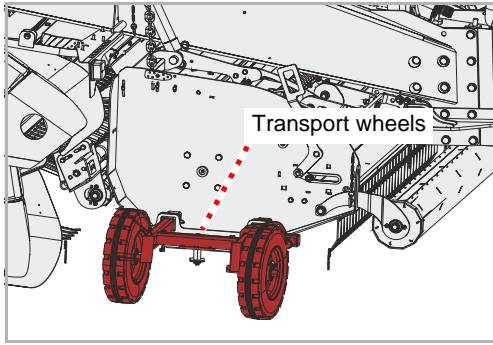

- ▶ Attach transport wheels on both sides of the chopper
- ▶ Lower the drawbar of the baler over the spindle until the transport wheels of the chopper come into contact with the ground

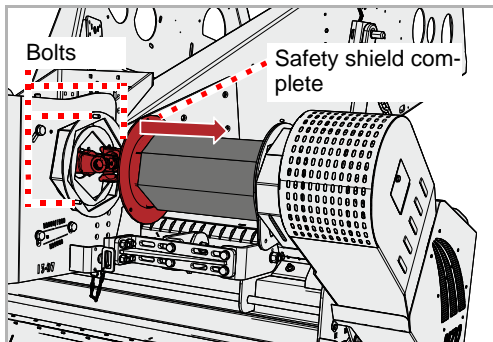

- ▶ Remove the nuts from the PTO shaft guard and push the PTO shaft guard in

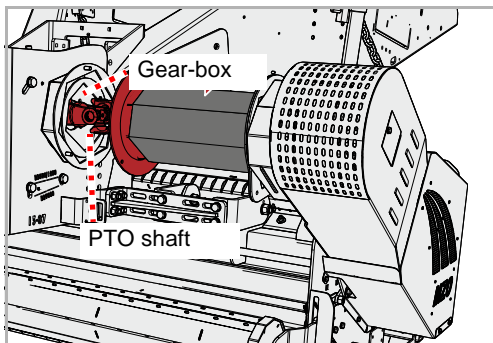

- ▶ Disconnect the chopper's PTO shaft from the gear box

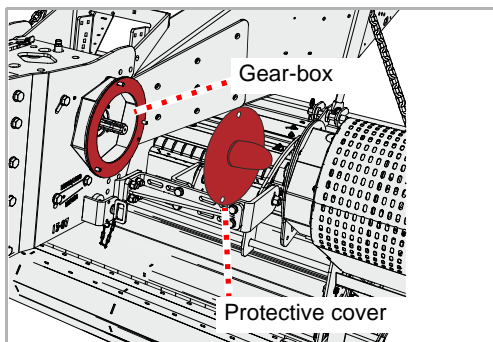

- ▶ Fit the protective cover to the gear box and secure it with nuts

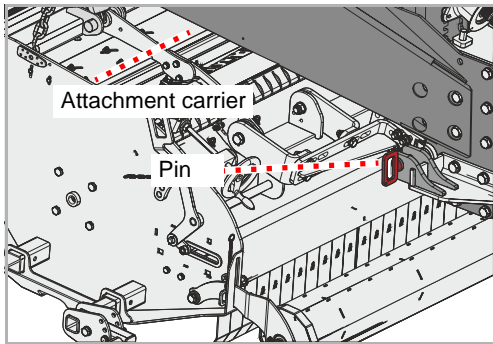

- ▶ Remove the pins on both sides of the attachment carrier

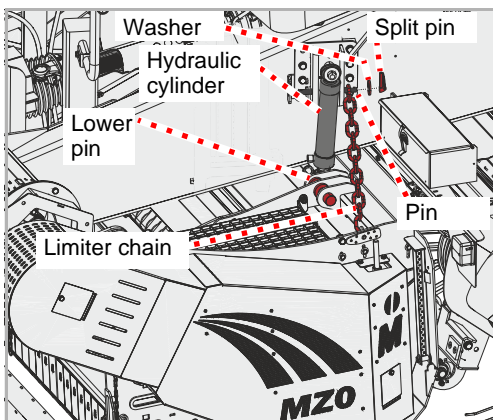

- ▶ Remove hydraulic cylinder from lower pin
 - ▶ Also remove the hydraulic cylinder on the other side from the lower pin
 - ▶ Remove the limiter chain from the pin
 - ▶ Also remove the limiter chain on the other side from the pin
 - ▶ Raise the drawbar of the baler over the spindle
- The chopper has now been disconnected from the baler

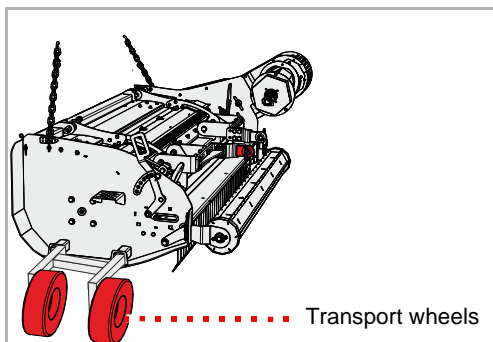

- ▶ Push the chopper to the designated set-down location

Storing the machine

After cleaning, the machine should be stored in transport position in a dry location and on a level and stable surface.

→ Section »Setting down the machine in a secure position«, Page 33



Apply a protective coating of oil during storage. Use only approved and biodegradable oil, e.g. rapeseed oil.

→ Chapter »Cleaning and care«, starting at page 32

For your safety

Special safety instructions



Requirements for conducting maintenance work

Only perform the maintenance work if you have the required expert knowledge and suitable tools.

A lack of specialist knowledge or the use of unsuitable tools can cause accidents.

Protect the machine from being started up accidentally

If the machine is coupled, only carry out repair and maintenance work and only rectify malfunctions on it if:

- The PTO stub shaft is off
- The engine is switched off
- The ignition key is removed

Serious accidents may be caused if the machine starts accidentally.



Welding work

Welding work may only be carried out by persons trained in welding who also have specialist knowledge of repairing agricultural machinery. Welding work which negatively impacts the machine's construction is prohibited.

Incorrect welding work could impair or destroy the machine's function. If in doubt, contact your dealer before carrying out any welding work.

Use replacement parts with identical properties

Many components have special properties that are essential for the stability and correct operation of the machine.

When replacing components, dimensions, stability and material quality must be guaranteed. We recommend the exclusive use of original replacement parts.

Use of replacement parts which do not correspond to requirements could cause damage to the machine or impaired performance.

Protective measures when handling oils or lubricants

Additives in oils and lubricants may have adverse effects on health. Since the hazardous material code does not require any special identification, please always observe the following:



Avoid skin contact

Avoid skin contact with these materials.
Contact can result in skin damage.

Protect your skin

When handling oils and lubricants, protect your skin with lotion or wear oil-resistant gloves.
Oils can be hazardous to your health.

Do not use oils for cleaning

Do not use oils or lubricants to clean your hands.
Swarf and abraded material in these materials can also result in injuries.

Change out of soiled clothing

Change out of clothing that is heavily soiled with oil as soon as possible.
Oils can be hazardous to your health.



- Collect old oil and dispose of it in accordance with statutory regulations.
- If your skin becomes irritated by oil or lubricants, contact a doctor immediately.

General information

This information relates to general maintenance work. For all maintenance work, the machine must be locked in the work position. If it is necessary to put the machine in its transport position for maintenance work, you will see an appropriate reference in the maintenance instructions.



Working with the grease gun:

One or two strokes with the grease gun are sufficient for lubrication. If you feel resistance during the second stroke of the grease gun, do not complete it.

Too much grease will force the bearings apart. This could allow dust and dirt to enter the bearing, resulting in premature wear.

Maintenance

Fundamentals

The following table contains a brief explanation of the most important terms used for maintenance.

Task	Version
Greasing	<ul style="list-style-type: none">• Apply grease to the slide surfaces using a brush
Lubrication	<ul style="list-style-type: none">• 1 - 2 Unless specified otherwise, one or two strokes with the grease gun provide sufficient lubrication
Oiling	<ul style="list-style-type: none">• Unless otherwise specified, use only vegetable-based oil such as rapeseed oil• Mineral oils are not suitable• The use of used oil will endanger your health and is also strictly prohibited
Replacement	<ul style="list-style-type: none">• Replace the component in question according to the instructions in the »Maintenance« chapter
Check	<ul style="list-style-type: none">• An inspection may be required in conjunction with the replacement of the component in question
Observe the maintenance intervals	<ul style="list-style-type: none">• All information is based on average machine usage• In the case of heavy usage (e.g. contract work), shorten the maintenance intervals accordingly• Shorter maintenance intervals may also be required under extreme operating conditions. Examples of extreme operating conditions include high levels of dust generation and high outside temperatures

Working on the baler



If you want to use the chopper as a step for adjustment work, maintenance work or repair work on the baler, please note the following points:

Maintenance work only in working position

Always lower the machine to the working position before carrying out maintenance work.

Excessive ground clearance can result in fall injuries.

Make sure that the chopper is in a horizontal position

Select a flat, level surface for the baler and chopper.

If the surface is sloping, this can result in injuries from slipping off the equipment.

Remove any soiling from the step surfaces

Remove any chopping residues and other soiling from the areas to be stepped on.

Soiling and chopping residues can result in injuries due to slipping.

Clean soiled shoes

Make sure your shoes are clean and robust. In particular, clean any soil or other dirt from the soles of the shoes.

Dirty shoes can result in injuries due to slipping

Only use the areas that are designed to be stepped on

On the chopper, only use the areas that are designed to be stepped on.

The use of other machine parts as steps can result in injuries due to slipping.

Ergonomic and safe work position

During all work, make sure that your work position is ergonomic and safe. The step surfaces are small and surrounded by obstacles. Please take this account when considering the possibility of performing work. Only perform work if you can stand securely.

An unsafe work position can result in fall accidents.

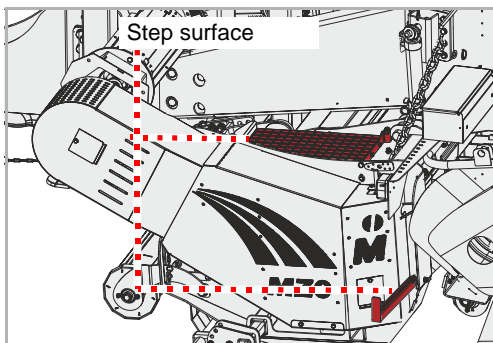

Maintenance

Step

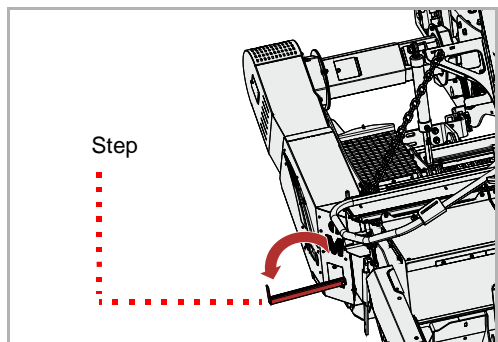

- ▶ Fold out step

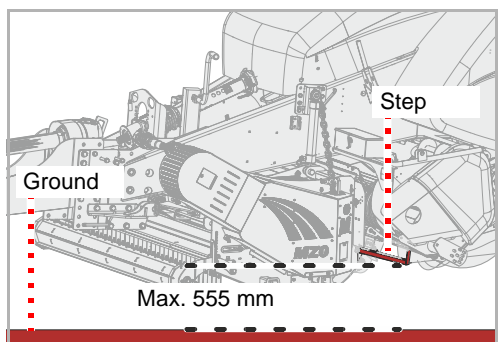

The space between the tread and the ground must not exceed 550 mm.

- ▶ Adjust the height of the chopper using the control unit on the tractor

After finishing the work:

- ▶ Fold the step back in and ensure that it locks securely

Screwed connections

Retighten screws

All bolts must be retightened:

- After the first hours of operation
- According to the frequency of use
- But at least once a season

General tightening torques

Tighten all screwed connections in accordance with the information in the table. If different tightening torques are necessary, they are specified in the chapter »Maintenance«. The minimum quality of the bolts is 8.8.

Bolt size	Quality of the bolts		
	„8.8“	„10.9“	„12.9“
	Tightening torques in Nm		
M6	9.9	14	17
M8	24	34	41
M10	48	68	81
M12	85	120	145
M16	210	290	350
M20	425	610	710
M24	730	1050	1220

Maintenance

Maintenance intervals and setting work

The information relates to average usage under the machine's normal operating conditions. Maintenance intervals are shorter for heavy usage, such as with hire companies, or for extreme operating conditions such as very dusty environments.

	After the first hours of operation	Once daily	After 25 hours of operation	After 50 hours of operation	Once per season	As required	In case of wear	grease / oil / lubricate	Check	Replacement	Cleaning
General											
Retighten all screws	•					•					
Visual inspection	•	•									
Bearing		•				•		•			
Pivots		•							•		
Hydraulics											
Hydraulic hoses Every 6 years										•	
Hydraulic hoses General						•	•			•	
Hydraulic cylinder		•		•		•		•	•		
Tools											
Fastenings on the rotor		•							•		
Condition, wear		•							•		•
Other											
Position of rotor		•						•			
Roller bearing		•						•			
Shafts and pins			•					•			
PTO shaft Protective cover		• •				• •		• •	• •	• •	• •
Transmission oil		•			•				•		•

Lubricating work

Lubricate bearings

The bearings must be lubricated regularly. Lubricate only with one or two strokes from the grease gun:

- According to the maintenance chart
- After heavy use
- But at least once a season

Bearings that require no maintenance must not be lubricated.

Overview of lubrication points

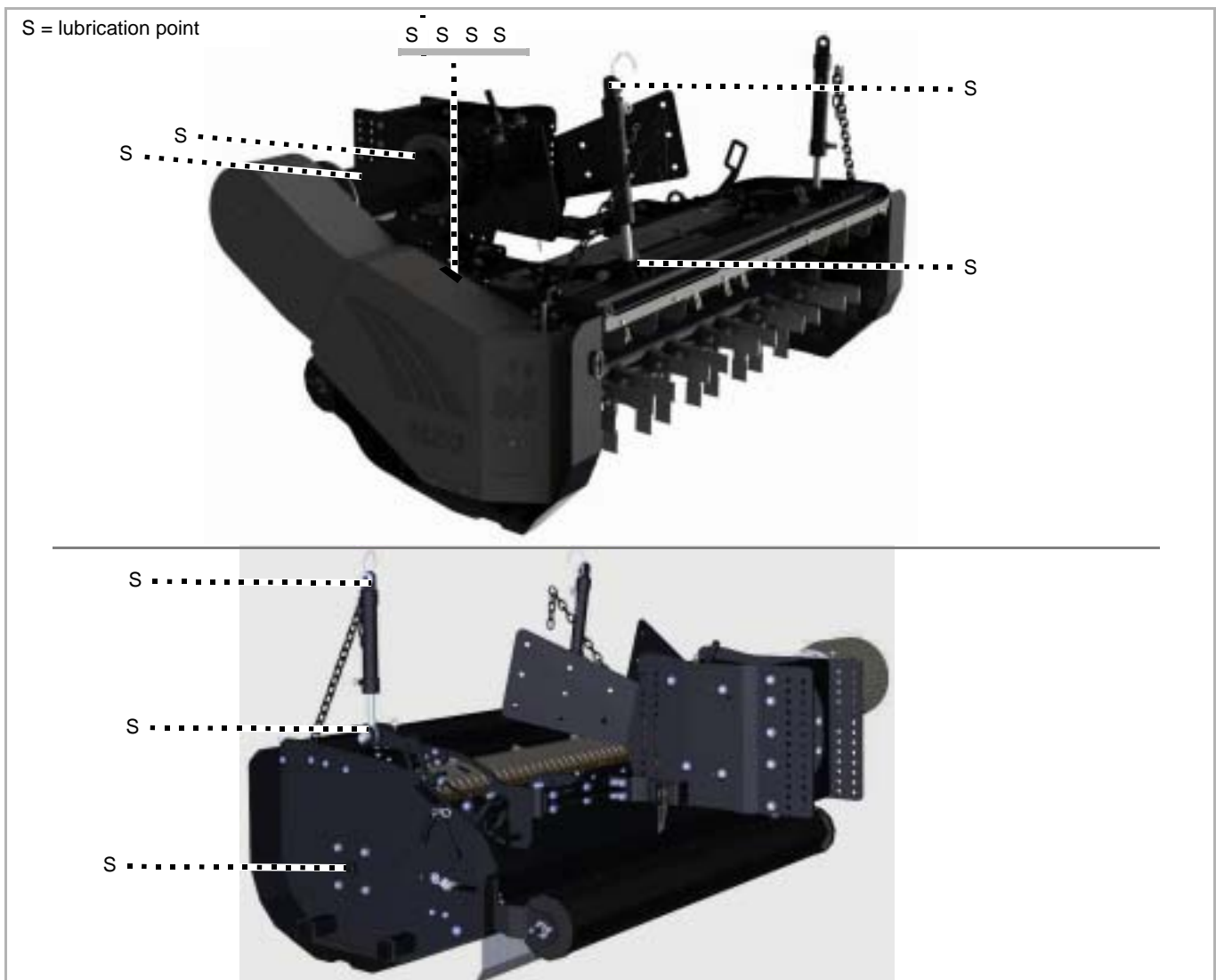

Other lubrication points

The following applies:

- In addition to the lubrication points shown in this operating manual, your machine may have other lubrication points
- As a rule, lubrication points are located at pivots or bearings. Therefore, inspect your entire machine for any such additional lubrication points.



The location of the lubricating nipple is usually shown on one component as an example. If multiple components of this kind exist, the lubricating nipples have to be lubricated at each of these components.

PTO shaft

The PTO shafts are heavily stressed. This means that regular maintenance is decisive for the PTO shafts' service life. Only the most important work is shown here.

Full maintenance work on the PTO shaft:

→ PTO shaft operating manual

Checking

Every 60 hours of operation

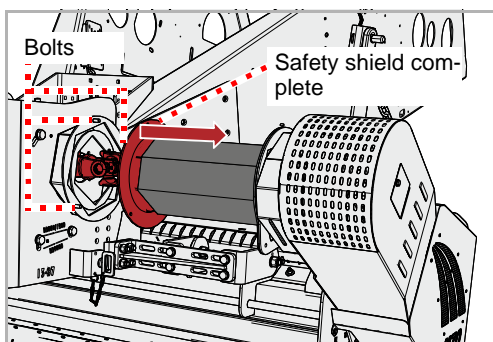

- ▶ Check the PTO shaft for contamination and clean if required. Dust in conjunction with oil and grease results in increased wear

- ▶ Remove the nuts from the PTO shaft guard and push the PTO shaft guard in

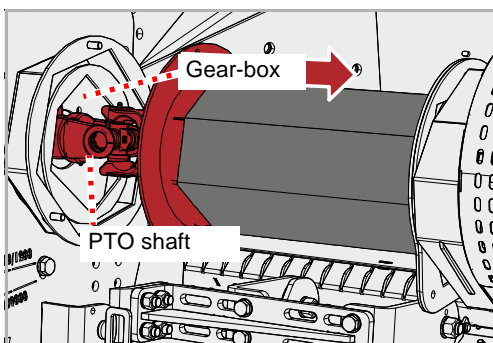

If the PTO shaft is heavily contaminated:

- ▶ Disconnect the chopper's PTO shaft from the gear box

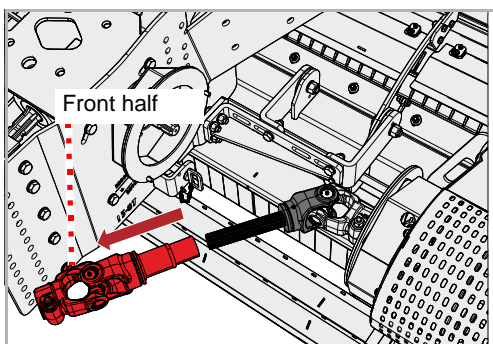

- ▶ Remove the front half of the PTO shaft
- ▶ Clean PTO shaft

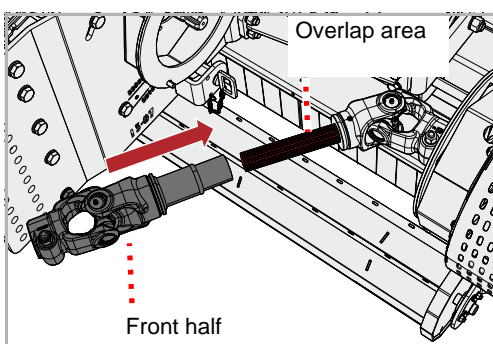

- ▶ Grease the overlap area
- ▶ Push the front half of the PTO shaft back in

Maintenance

- ▶ Check the universal joints of the PTO shaft for wear

If the universal joints are heavily worn:

- ▶ Replace the universal joints
→ PTO shaft operating manual

- ▶ Fit the PTO shaft guard and secure it with nuts

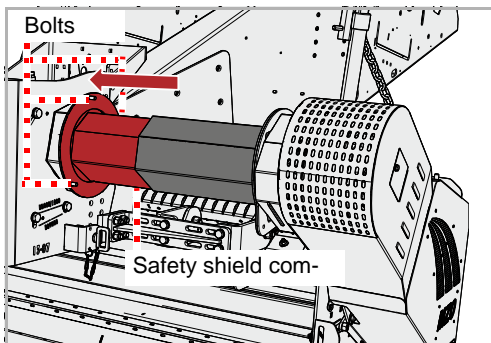

Lubrication

Every 50 hours of operation

In case of heavy usage or in extreme operating conditions, such as a very dusty environment, more frequent lubrication is required.

- ▶ Remove the bolts from the maintenance flaps
- ▶ Open the maintenance flaps

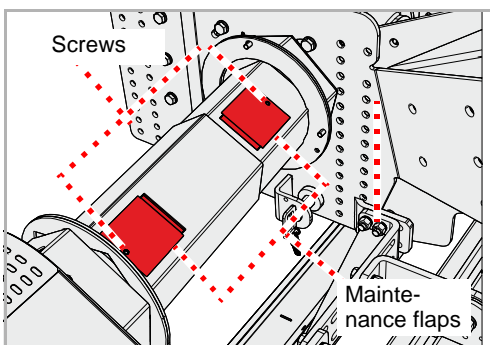

- ▶ Lubricate in the universal joint with 1 - 2 strokes of the grease gun.
- ▶ Reinsert the maintenance flaps and secure them with bolts

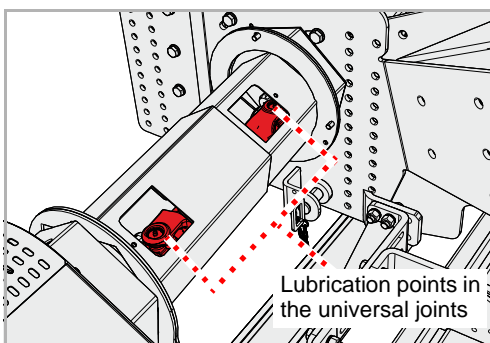

Transmission oil

The gearbox oil must conform to the specification.

→ Chapter »Familiarising yourself with the machine« paragraph »Technical specifications«, page 20

Check

Twice per season

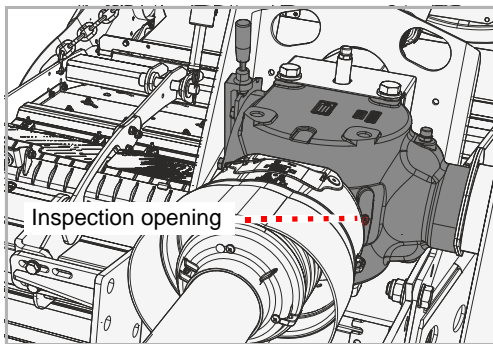

- ▶ Loosen the screw on the inspection opening with an Allen key and remove the screw
- ▶ Check the oil level. The oil level must reach the lower edge of the inspection opening.
- ▶ Retighten the screw at the inspection opening

Refilling

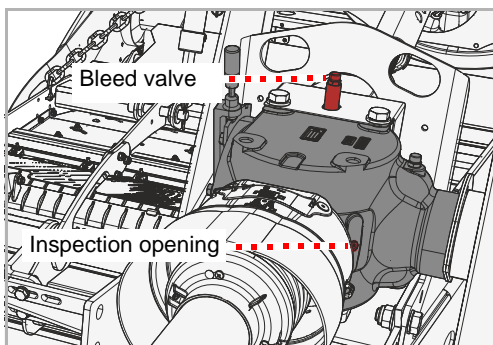

- ▶ Loosen the screw on the inspection opening with an Allen key and remove the screw
- ▶ Unscrew the bleed valve
- ▶ Use a funnel to fill with gear oil of the appropriate specification until the oil level reaches the lower edge of the inspection opening
- ▶ Retighten the screw at the inspection opening
- ▶ Screw the bleed valve back in

Replacement

1x per season

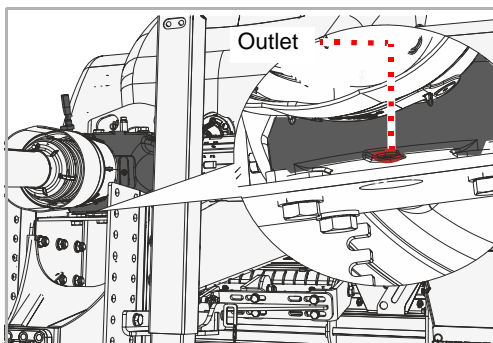

- ▶ Place a collection container under the outlet for the waste oil
 - ▶ Loosen the screw on the outlet with an Allen key and remove the screw
 - ▶ Allow the oil to drain out fully
 - ▶ Replace the screw at the outlet
 - ▶ Refill with new gear oil
- Section »Refilling«

Chopping blades

As required

The chopping blades must be replaced if:

- Are damaged
- Are heavily worn
- The bore on the chopping blade is worn
- The fastening bolt or the fastening nut is worn

It is important that the rotor runs without unbalance. Therefore:

- Always replace chopping blades with the same type
- Always replace chopping blades opposite each other at the same time
- In case of wear it is best to replace the entire set of chopping blades



Secure the machine

Work can only be carried out on a machine secured against rolling away and dropping. To prevent dropping, for example, permitted and correctly dimensioned support legs can be used.

If the machine is not secured against rolling away and dropping, serious or fatal accidents could result.

New tools – new nuts and bolts

When replacing the tools, the nuts and bolts must also be replaced. *If the nuts and bolts are not replaced, the worn bolts may break. Tools may become detached during work and be flung out. Even persons outside of the hazard area could be seriously injured or killed.*

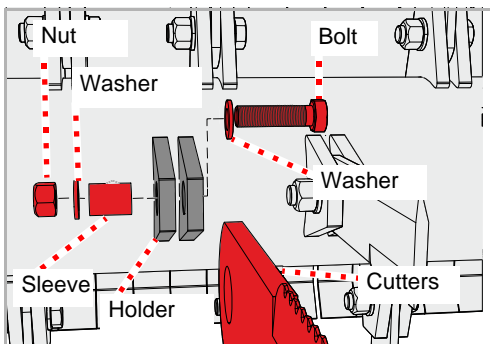

- ▶ Secure the machine against rolling away and dropping
- ▶ Loosen the nuts and remove the bolts
- ▶ Remove the old chopping blade
- ▶ Remove the sleeve and check for damage

If the sleeve is damaged or worn

- ▶ Replace the sleeve
- ▶ Refit the sleeve
- ▶ Check the bolt for damage

If the bolt is damaged or worn

- ▶ Replace the bolt
- ▶ Insert a new chopping blade
- ▶ Insert a screw with washers and secure it with a new nut

V-belt

As required

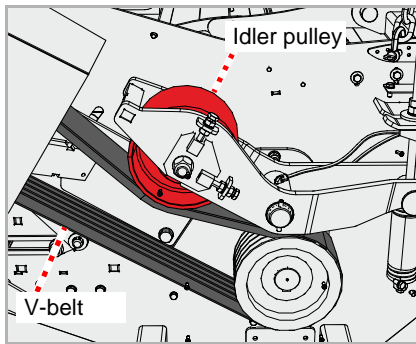

The V-belt is tensioned by an idler pulley. If the V-belt is not sufficiently tensioned, it must be retensioned. If there are any tears or the V-belt is damaged, it must be replaced.

Checking

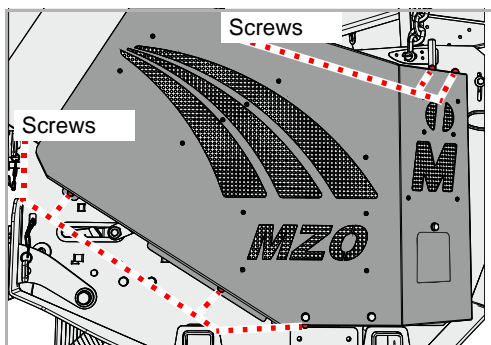

You will have to remove the safety cover for the purpose of checking.

- ▶ Remove the bolts and the safety cover
- ▶ Check the V-belt for damage
- ▶ Reassemble the safety cover

Replacement

If there are any tears or other damage on the V-belt, it must be replaced.



If the V-belt has been retensioned or is new, it must be precisely aligned. This work should therefore be carried out by a specialist workshop.

Fault elimination

Faults can often be eliminated quickly and easily. In the event of hydraulic problems, first check:

- Are the hydraulic hoses properly connected?
- Is the control valve at the tractor defect?
If so, contact your dealer.
- Is the hydraulic pump of the tractor defective?
If so, contact your dealer.

Before calling Customer Service, refer to the table below to check whether the fault is one you can eliminate yourself.

Fault	Cause	Remedy
Strong vibrations and high noise development	Tools are worn	Replace the tools
	One or more tools are missing	Replace tools
	Tools are damaged	Replace the tools
	Bearings for the rotor are worn	Have the bearings replaced
	Foreign bodies, such as wire, are wound around the rotor	Remove foreign bodies
	Tools have become loose	Tighten nuts on screws
	Speed of rotation of the PTO stub shaft is not set correctly	Set the correct speed of rotation on the PTO stub shaft
	Rotor not correctly counterbalanced	Check balancing and rebalance the rotor if necessary
Tools wearing quickly	The tools are working too deeply	Set correct working depth
Material cut too rough and cut material not distributed evenly	Drive speed too high	Reduce the drive speed
	The tools are working too deeply	Set correct working depth
	The tools are working too high	Set correct working depth
	V-belt worn	Have the V-belt replaced at a specialist workshop
	V-belt not correctly tensioned	Have a specialist workshop check the V-belt tension and retension it if necessary
	Speed of rotation of the tractor PTO stub shaft is too low	Increase the rpm
	Tools are worn	Replace the tools
	Guide vanes have been incorrectly adjusted	Adjust the guide vanes correctly
	The machine is not standing parallel to the ground	Adjust the machine correctly
Rotor does not turn	Rotor is blocked by a foreign body	Remove foreign bodies
	Gear box is switched off	Switch on the gear box

Fault	Cause	Remedy
PTO shaft rotating, rotor is not	V-belt torn	Replace the V-belt
Unusual noises from the PTO shaft	Insufficient lubrication	Lubricate the PTO shaft
Gear box overheating	Incorrect oil specification	Change oil and select oil with correct specification
	Oil too old	Change oil
	Oil level too low	Fill the oil to the lower edge of the inspection opening
	Machine overload	Maintain rpm in correct region, adjust driving speed to suit the work, maintain performance area (avoid excessively heavy growth or excessively thick branches)
High wear on V-belts V-belts running hot Power transmission not optimal	The tools are working too deeply and touching the ground	Set correct working depth
	Pulleys not aligned in parallel	Have pulleys correctly aligned
	V-belt is worn	Have the V-belt replaced at a specialist workshop
	V-belt is not correctly tensioned	Check the tension jack
Oil leaking from the gear box	Sealing rings worn or damaged	Have sealing rings replaced
Drive elements broken	Machine was started up abruptly or is blocked by foreign bodies	Have defective drive element replaced. Start the machine up slowly.

Disposal of the machine

When the service life of your machine is over, it must be disposed of properly. Please observe currently valid disposal regulations.

Metal parts

All metal machine components can be sent for metal recycling.

Plastic parts

All plastic parts are marked and can be recycled.

Oil

Collect fluid from the hydraulic system in a suitable container and dispose of at a used oil collection facility.

EC Declaration of Incorporation

In accordance with the EC Directive

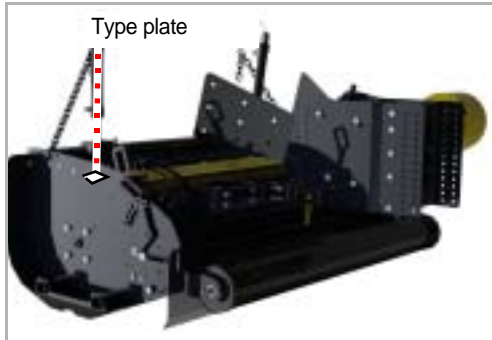

Müthing GmbH & Co. KG Soest
Am Silberg 23
D-59494 Soest

assumes sole responsibility for declaring that the following product complies with EC Directive 2006/42/EC:

MZO 200 and additional equipmentn

Assorted samples of harmonized standards:

- DIN EN ISO 4254-1
- DIN EN ISO 4254-12
- EN 13524

The following essential requirements of Annex I of the Machinery Directive 2006/42/EC have been applied and are fulfilled:

The incomplete machine must not be put into operation until it has been established that the machine in which it will be installed satisfies the provisions of the Machinery Directive.

The special technical file required by Annex VII Part B of the Machinery Directive 2006/42/EC has been created and shall be presented to the competent national authorities in response to a duly substantiated request.

Soest, 28.10.2022

Andreas Rohde
CEO and authorised person for compiling technical documentation

Copy of the type plate/serial number entry

Machine type: Straw chopper attachment

Machine Name:

Working width:

Serial number:

Year of construction:

UK Declaration of Incorporation

UKCA

Müthing GmbH & Co. KG Soest
Am Silberg 23
D-59494 Soest
Germany

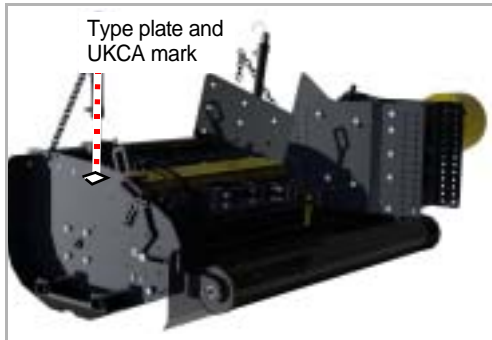

declares under sole responsibility that the machine conforms with the following directives:

- Supply of Machinery (Safety) Regulations 2008

Assorted samples of harmonized standards:

Machine designation	MU-MZO 200 and additional equipment
---------------------	-------------------------------------

The following essential requirements of the Annex to the Supply of Machinery (Safety) Regulations 2008 are applied and complied with:

General principles	1.1.2.-1.1.6
Protective measures against mechanical hazards	1.3.1-1.3.4; 1.3.7-1.3.8
Requirements for protective devices	1.4.1-1.4.2
Risks due to other hazards	1.5.1-1.5.2; 1.5.4; 1.5.6; 1.5.8; 1.5.15;
Maintenance	1.6.1; 1.6.3; 1.6.4-1.6.5
Information	1.7.1-1.7.4

The machine may only be put into operation if it has been installed on an approved mulcher by a specialist workshop.

The special technical documents corresponding to the machine have been created according to Annex VII, Part B.

Soest, 28.10.2022

Andreas Rohde
 CEO and authorised person for compiling technical documentation

Copy of the type plate/serial number entry

Type of machine: Straw chopper attachment

Model:

Working Width:

Machine ID:

Production Year:

MU-MZO

A			
assembly	19		
C			
Care	32		
Cleaning	32		
Connecting			
Hydraulics	24		
D			
Declaration of Conformity	53		
Direction information	13		
E			
Employer	8		
F			
Fault	50		
Features	18		
H			
Hydraulics			
Connecting	24		
I			
Instruction	8		
L			
labels, see warning signs			
Lubricate bearings	43		
M			
Machine			
Storing	35		
Maintenance			
General information	37		
Maintenance intervals	42		
Overview of lubrication points	43		
Safety	36		
P			
Parking	33		
Pictograms	9		
Protective procedure			
Oils or lubricants	37		
R			
Range of application	17		
Carbide M shackle flails	17		
S			
Safety	10		
Agricultural training	13		
Care and maintenance intervals	15		
Care and maintenance work	15		
Check the screwed connections	16		
Cleaning	16		
Coupling	13		
Proper use	17		
Putting the machine into operation	13		
Warning signs	10		
Welding work	16		
Scope of delivery	21		
Screwed connections	41		
Setting down the machine in a secure position	33		
Symbols	9		
T			
Target group	8		
Task	30		
Technical specifications	20		
Tightening torques			
General	41		
Transport without coupling	28		
W			
Warning signs	10		
Meaning	11		
Work position	29		
Working width	25		