



OPERATION MANUAL

EN | Original

MU-Pro/F Vario and MU-Pro/F Trail Vario

FROM PRODUCTION 2020

EDITION 11.2022

REFERENCE NUMBER MU-Pro/F-Vario-Trail_BA_20_EN_2022-11

Machine identification

In order for your dealer to assist you as efficiently as possible, you will need to provide some information about your machine. Please enter the information here.

Designation

Working width

Weight

Machine number

Additional equipment

Dealer's address

Manufacturer's address

Müthing GmbH & Co. KG Soest
Am Silberg 23
59494 Soest
Germany

Handover declaration

- Fill out this sheet with your dealer.
- Then separate this sheet from the operating manual and send it to the manufacturer within 10 days of delivery. Only in this way will the guarantee be effective from the date of delivery

To
Müthing GmbH & Co. KG Soest
Am Silberg 23
59494 Soest
Germany

I have bought the machine described below from Müthing GmbH & Co. KG Soest, and confirm full delivery and handover of the machine including the operating manual and spare parts list, as well as training in operating the devices with safety instructions and warning information from your dealer.

I confirm additionally that I have read and understood the operating manual and am in agreement with the information contained therein. This applies in particular to the chapter Safety.

Client

Name		First name	
Address			
Post code		Town/city	
Telephone		Fax	
E-mail		Date	

Machine

Machine	MU-	Serial number	
Working width		Gear-box	
Rigid mounting		Non-rigid mounting	
Year of construction		Delivery date	
Delivered by			

Signature of client

Signature and stamp of sales partner

Handover declaration

Handover declaration – Copy

– This sheet remains with the client in the operating manual

I have bought the machine described below from Müthing GmbH & Co. KG Soest, and confirm full delivery and handover of the machine including the operating manual and spare parts list, as well as training in operating the devices with safety instructions and warning information from your dealer.

I confirm additionally that I have read and understood the operating manual and am in agreement with the information contained therein. This applies in particular to the chapter Safety.

Client

Name		First name	
Address			
Post code		Town/city	
Telephone		Fax	
E-mail		Date	

Machine

Machine	MU-	Serial number	
Working width		Gear-box	
Rigid mounting		Non-rigid mounting	
Year of construction		Delivery date	
Delivered by			

Signature of client

Signature and stamp of sales partner



Table of Contents

Handover declaration	3	Mulching	62
Handover declaration – Copy	5	Drawn variant	62
About this operating manual	8	Separated variant	63
Target group	8	Checking	66
Safety	8	Task	67
Instruction	8	Switching on	69
Other applicable documents	8	Individual control [+]	69
Symbols	9	Cleaning and care	70
Safety	10	Cleaning	70
For your safety	10	Care	70
Warning signs	10	Parking and storage	71
Definitions	15	Setting down the machine in a	
Who is allowed to operate the machine?	15	secure position	71
Coupling	16	Drawn variant	71
Centre of gravity	17	Separated variant	80
Road transport	19	Storing the machine	89
Putting the machine into operation	19	Maintenance	90
Uncoupling the machine	21	For your safety	90
Care and maintenance	21	General information	91
Further regulations	22	Maintenance intervals and setting work	94
Familiarising yourself with the machine .	23	Lubricating work	96
Range of application of the machine	23	PTO shaft	99
Features of the machine	24	Secure the machine	100
Designation of components	25	Transmission oil	105
Technical specifications	27	air pressure brake system	107
Delivery and assembly	31	Tools	108
Checking the scope of delivery	31	V-belt	109
Coupling the machine	32	Runners	112
Drawn variant	32	Accessory	113
Separated variant	35	2-Cut double-cut rotor	113
Hydraulics	41	Cutting bar	113
Electrics	42	short chopping bar	113
Compressed air	43	Scraper	113
Preparation	46	Operating hours counter	114
Working width	46	Additional guard	114
Drawn variant	48	Individual control	114
Cutting level	49	Fault elimination	115
Mechanical cutting bar [+]	50	Disposal of the machine	117
Hydraulic cutting bar [+]	50	EU-conformity declaration	118
Depositing cut material	51	EC Directive	
Additional guard [+]	57	2006/42/EG	118
Driving on the road	58	UK Declaration of Conformity	119
Transport position	58	UKCA	119
Lighting equipment	60	Index	120
Control devices	61		
Transport without coupling	61		

About this operating manual

Target group

This operating manual is intended for trained machine operators and persons who are otherwise qualified to carry out landscape work and who have received training in how to use this machine.

Safety

Familiarise yourself with the contents of this operating manual which are relevant for your activity before commissioning or assembling the machine. Always read through the safety instructions in the chapter "Safety" and observe the warning information in the individual chapters. In this way, you will achieve optimum work results and operational safety.

For the employer

Staff must be instructed in the safe handling of the machine before the initial commissioning. Untrained or unauthorised persons are not permitted to use the machine.

The following are included in this training:

- Checking that staff possess the necessary requirements for safely handling the machine.
- Handing out the operating manual and the other relevant and applicable documents or an intensive course of training which, in particular, includes the safe handling of the machine.

Regular instruction sessions

Instruct your staff regularly, but at least once a year, concerning the basic procedural measures for safely handling the machine.

Instruction

You will receive training from your dealership concerning using the controls, safe operation and care of the machine. Commissioning without first receiving training is not permitted.

Other applicable documents

In addition to the operating manual, other documents also form an integral part of the machine:

EU-conformity declaration	Integral part of this operating manual → Chapter »EU-conformity declaration«, Page 118
Spare parts list	Integral part of the delivery with this machine
PTO shaft operating manual	Integral part of the delivery with this machine
If the machine is used on public roads:	
Certificate for obtaining the operating permit § 21 SVZO	Upon request to obtain the 40 km/h registration documents for public roads
For machines with air brake system: Certificate from German TÜV (Technical Inspection Association)	Upon request to apply for operating permit from relevant road traffic authority

Front attachment or rear attachment

The flail mower for rear attachment and the flail mower for front attachment are provided with separate operating manuals.

Operating manual of approved flail mower for rear attachment or front attachment	MU-PRO Vario
--	--------------

About this operating manual

Symbols

In order to make this manual clear and easy to read, we have used various symbols. They are explained below:

- A bullet point accompanies each item in a list
- ▶ A triangle indicates operating functions which must be performed
- An arrow indicates a cross-reference to other sections of this manual
- [+] A plus sign indicates an accessory that is not included in the standard version.

Pictograms

We have also used pictograms to help you find instructions more quickly:



The warning triangle indicates warning information. Failure to observe these safety instructions can result in:

- Moderate to serious injury
- Fatal injury

You will find the warning information associated with individual operations, where it is important to observe the warning information before these operations are carried out.

You will also find safety instructions in the chapter »Safety« which cannot be assigned to any particular operations, but increase your ability to work safely in different situations.



This sign indicates important instructions regarding the machine. Failure to observe these safety instructions can result in:

- Serious faults in the correct operation of the machine.
- Damage to the machine



This symbol indicates tips for assembly or adjustment work.



This symbol indicates examples that help you to understand the instructions better.

Parts in the text which refer to individual machines or to conditions have a colored background. After the colored section, the text then applies again to all machines. For example:

Only for machines with a pneumatic brake system

- ▶ Connect brake hoses
- ▶ Connect hydraulic hoses

Safety

For your safety

This chapter contains general safety instructions. Each chapter of the operating manual contains additional warning instructions which are not described here. Observe the safety instructions:

- In the interest of your own safety,
- In the interest of the safety of others
- To ensure the safety of the machine

Numerous risks can result from handling landscaping machines the wrong way. Therefore, always work with particular care and never under time pressure.

For the employer

Inform personnel working with the machine of these safety instructions at regular intervals and according to statutory regulations.

Warning signs

On the machine you will find labels that serve to ensure your safety. The labels must not be removed. If labels become illegible or begin to peel off, new labels can be ordered and attached in the appropriate places.

Drawn variant

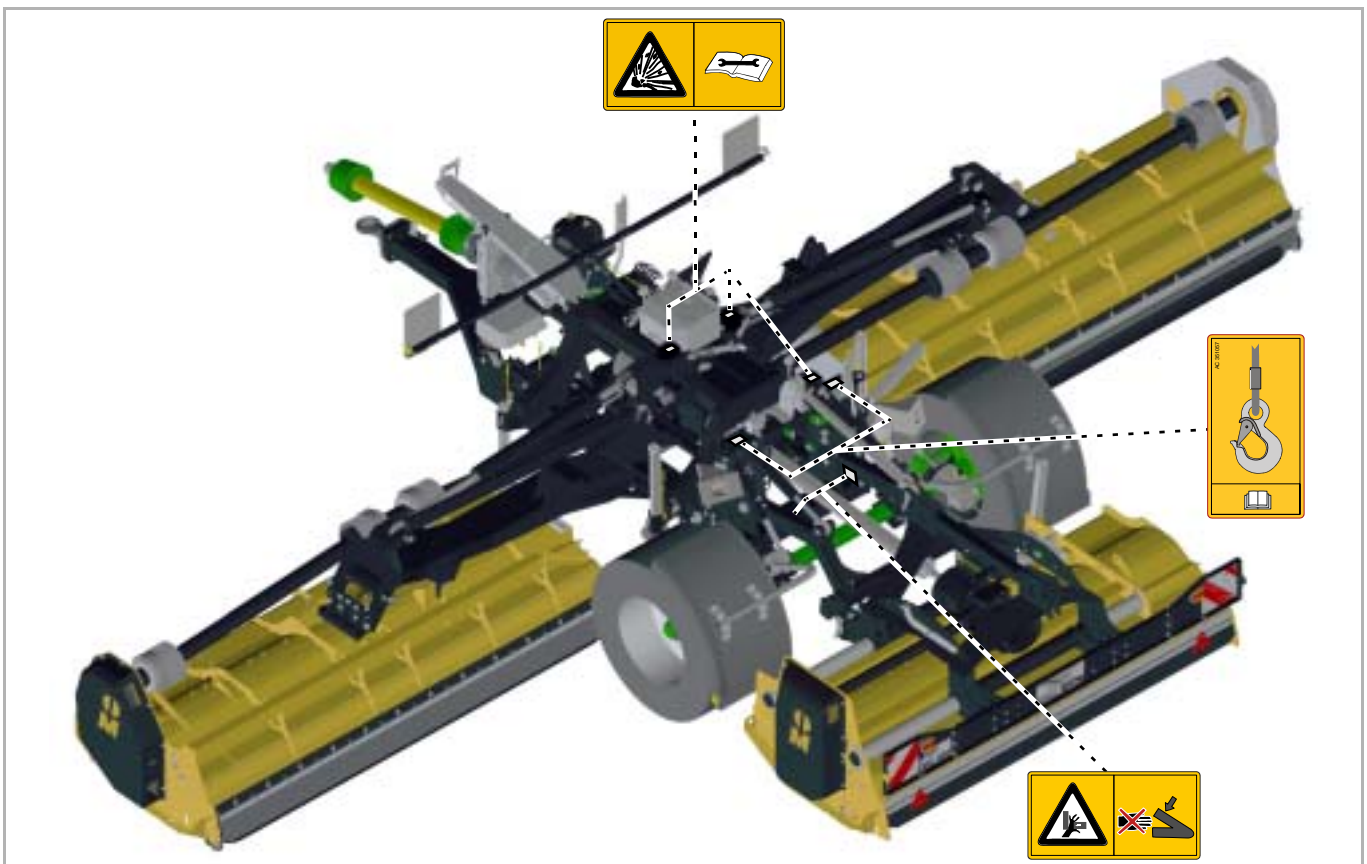
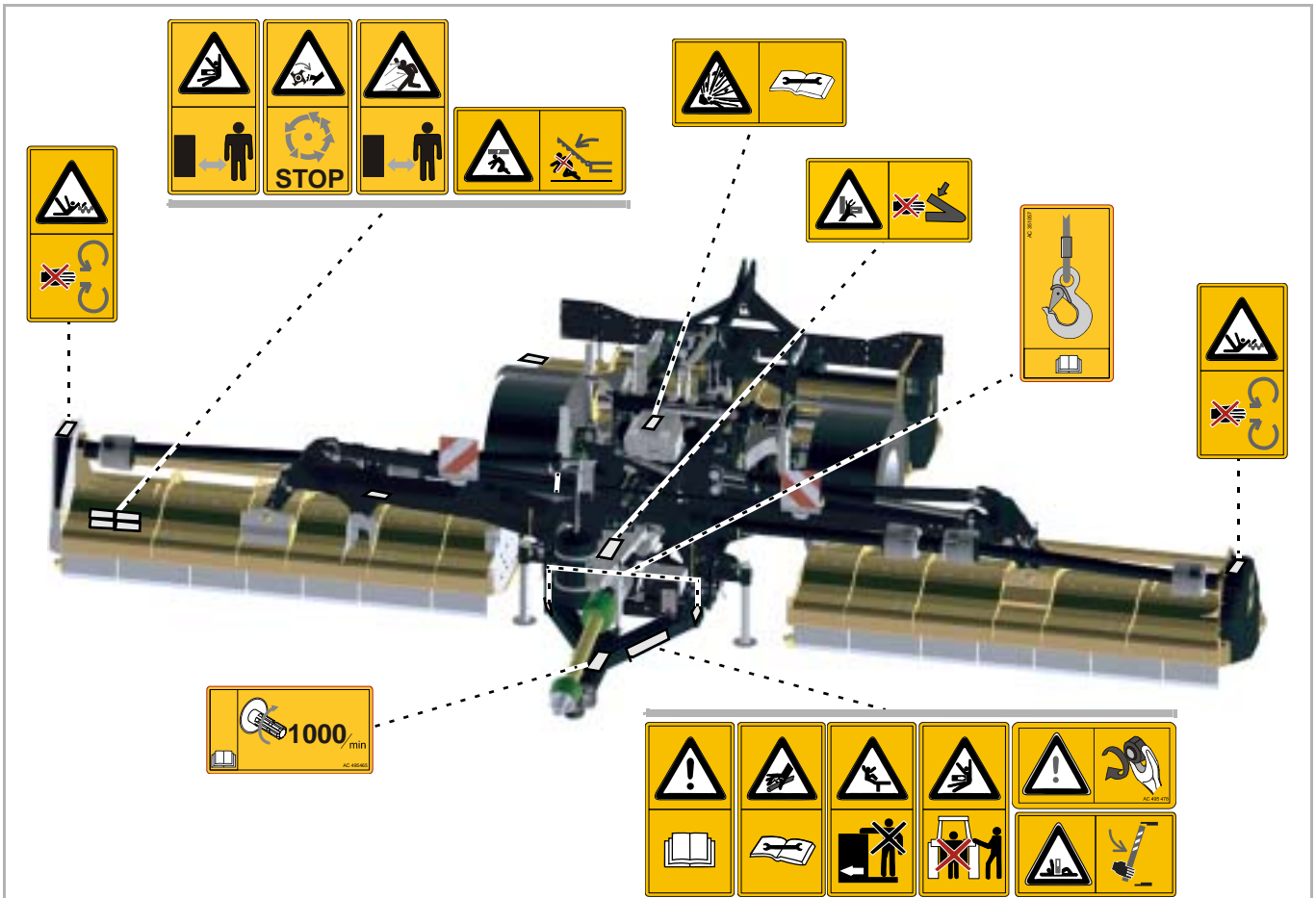

Safety

Separated variant

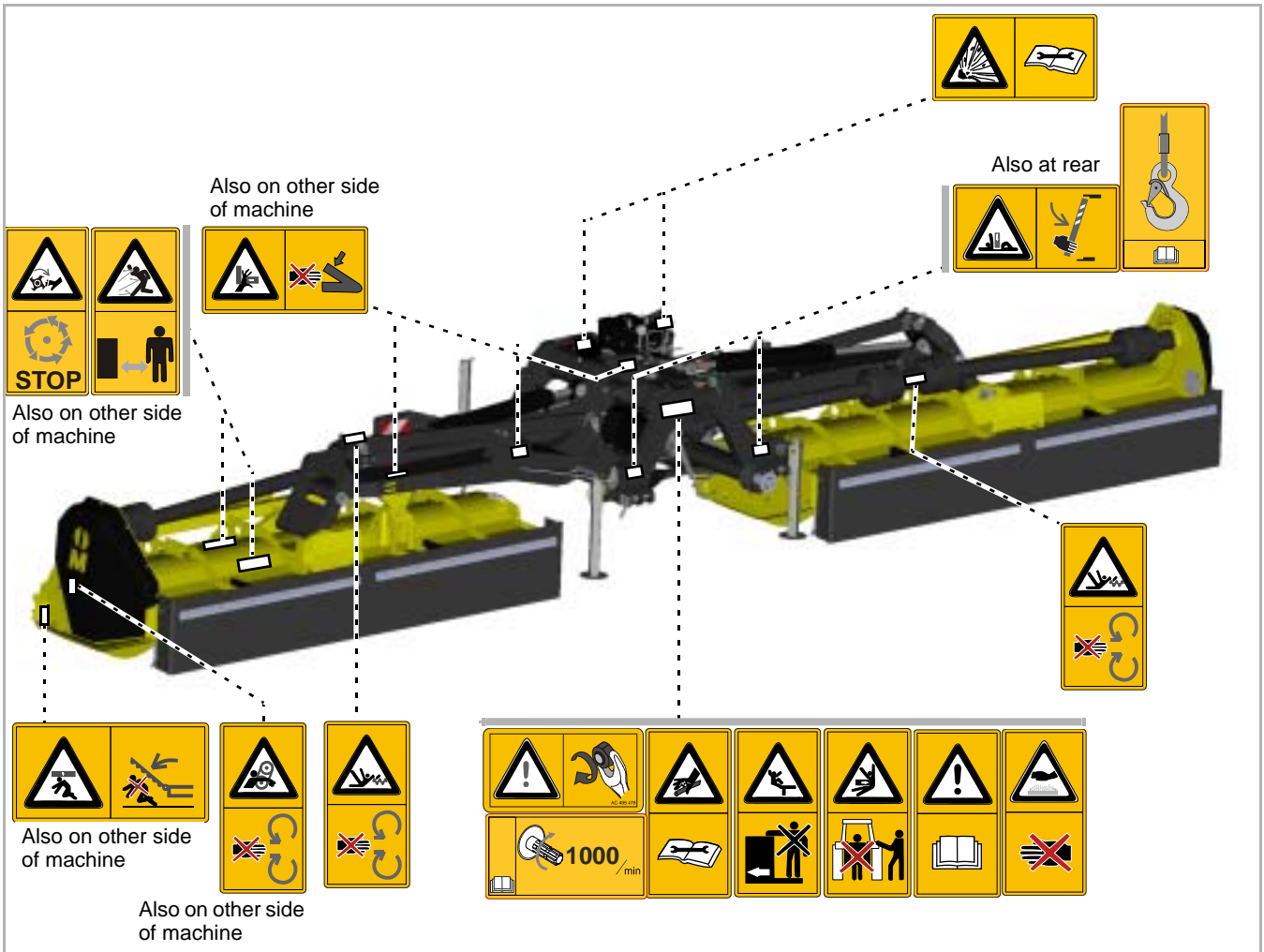

Meaning of warning signs Warning signs



Read the operating manual carefully and follow the instructions
Commissioning of the machine must not take place before the operating manual has been read and understood. This particularly applies to safety instructions.



Do not stand between the tractor and the machine
Standing between the tractor and the machine with the engine running is prohibited, especially during coupling and uncoupling. The tractor must be additionally secured against rolling away.



Riding on the machine is prohibited
It can result in serious or even fatal injury.



Proceed with great care in the event of leaking hydraulic fluid
Do not look for leakage points without correct protection. Fine oil jets could penetrate eyes and skin under high pressure. Observe the corresponding safety instructions in the operating manual.



Do not remove protective devices
Never open or remove the protective devices while the tractor's engine is running. Never operate the machine without the protective device.



Be aware of the danger of being pulled in
There is a danger of being pulled into the PTO shaft in the event of inappropriate use.



Hot surface
The gear box can become hot during prolonged operation. Touching hot surfaces can cause burns. Wait until the gear box has cooled down before working on it.



Shackles
Only raise the machine using loading equipment at the points indicated.



Rotating and trailing machine parts

Only approach the machine when all machine parts have stopped moving.



Danger of objects being thrown out

During operation, there is a danger of objects such as stones being picked up and thrown out by the machine. Ensure that no persons are present in the hazard area.



Danger from moving machine parts

Nobody is permitted to remain within the hazard area during operation.



Caution, risk of tipping

The machine or parts can tip over. Attach the safety supports before you stand in the hazard area. To uncouple, use the struts provided and position on firm ground.

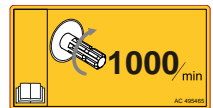

Check the rotational speed of the PTO stub shaft

Connect PTO shaft to a PTO stub shaft with an appropriate rpm. Always switch off the PTO stub shaft when working on the machine.



Do not stand in the slewing range

There is an extreme risk of injury within the slewing range from slewing or folding machine parts.



risk of crushing

Avoid the hazard area. Gaps between components may become smaller or disappear completely.



Retighten screws

After the first hours of operation, and as required, all screws must be checked and tightened if necessary. Vibrations might have loosened the screwed connections.



Caution, risk of explosion

The pressure accumulator contains pressurised gas and oil. Removal and repair work must only be carried out by qualified specialists.

Definitions

All direction information is given in relation to the direction of travel of the machine:

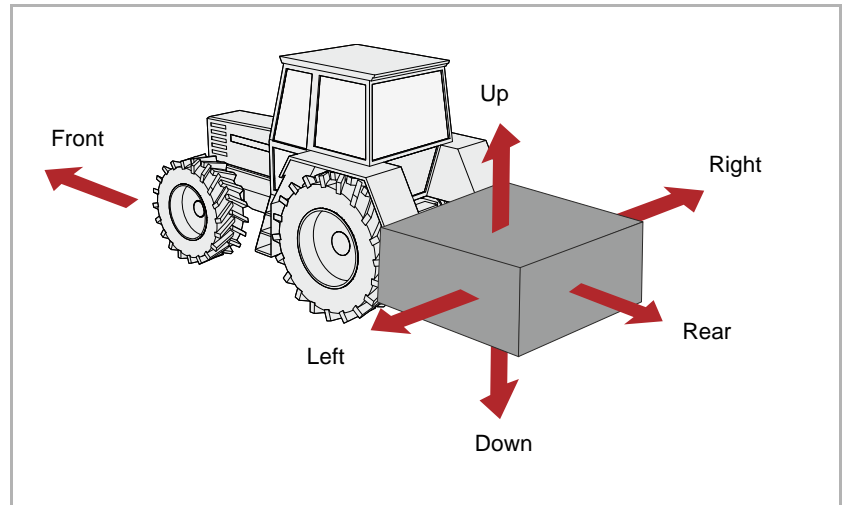

Who is allowed to operate the machine?

Only qualified personnel

Only qualified persons who have been informed of the dangers associated with handling the machine are permitted to operate, service or repair the machine. As a rule, such persons are trained and experienced in agricultural work or have been thoroughly trained in a similar fashion.

Coupling

Increased risk of injury

When the machine is being coupled to the tractor, there is an increased risk of injury. Therefore:

- Only couple the machine with the road chassis raised
- Secure the tractor against rolling away
- The tractor and machine must belong to the same category
- Never stand between the tractor and the machine during coupling
- Actuate the three-point power lift system slowly and carefully

Failure to observe these instructions can result in serious or fatal injury.

Connect electric wires or cables only after mounting the attachment

The electrical supply to the tractor must not be connected when the lighting equipment is being fitted. Short circuits and damage to the electronics are possible.

Only connect hydraulics at zero pressure

Only connect hydraulic hoses to the tractor hydraulic system if the tractor and machine hydraulic system is at zero pressure. A hydraulic system under pressure can trigger unpredictable machine movements.

High pressures in the hydraulic system

The hydraulic system is under high pressure. Regularly check all lines, tubes and screwed connections for leaks and externally visible damage. Only use suitable tools when looking for leaks. Rectify any damage immediately. Oil escaping under pressure may result in injuries and fires. In the event of injuries, seek medical attention immediately.

Color-coded hydraulic hoses

To prevent operating errors, plug sockets and plugs for hydraulic connections between the tractor and the machine must be color-coded. Wrongly connected hydraulic hoses can trigger unpredictable movements of the machine.

Centre of gravity

Observe the total weight, axle loads, tyre load-bearing capacity and minimum ballast specifications

The front or rear mounting of machines must not cause the carrier vehicle's permissible total weight, permissible axle loads, or tyre load-bearing capacity to be exceeded. The front axle must bear at least 20 % of the empty weight of the carrier vehicle to ensure steering capability.

You can calculate:

- Total weight
- Axle loads
- Minimum added weight

Data

For this calculation, some data is required out of the following documents and measurement results:

- Operating manual of carrier vehicle
- This operating manual
- Measurement results from carrier vehicle and attached machine

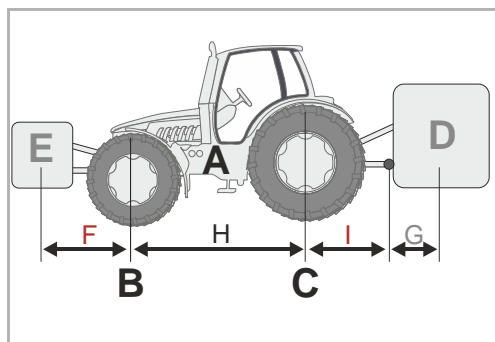

Data from the operating manual of the carrier vehicle:

- (A) unladen weight
- (B) front axle load
- (C) rear axle load
- (H) wheel base of carrier vehicle

Please take into consideration, for example, the weight of water in the tyres, accessories, etc.

Data from this operating manual:

- (D) Total weight of the machine when rear-mounted; the supporting load with the machines attached
- (E) Total weight of the machine when front-mounted
- (G) Distance between the lower link ball midpoint and the machine's centre of gravity when rear-mounted. With machines attached, $G=0$.

Data which you can determine by measuring:

- (F) Distance between the machine's centre of gravity when front-mounted and the front-axle midpoint
- (I) distance between the rear axle midpoint and the lower link ball midpoint. For rear-mounted machines between rear axle midpoint to drawbar coupling midpoint or hitch ball

Safety

Calculation

The measured values can now be inserted into the formulas.

Ballast with front weights

Calculating the **ballast with front weights** on rear-mounted machines.

$$\text{Front ballast in kg} = \frac{D \times (I + G) - (B \times H) + (0,2 \times A \times H)}{F + H}$$

Ballast with rear weights

Calculating the **ballast with rear weights** on front-mounted machines.

$$\text{Rear ballast in kg} = \frac{(E \times F) - (C \times H) + (0,45 \times A \times H)}{H + I + G}$$

Front axle load

Calculating the **actual front axle load**

$$\text{Front axle load in kg} = \frac{E \times (F + H) + (B \times H) - D \times (I + G)}{H}$$

Total weight

Calculating the **actual total weight**

$$\text{Total weight} = E + A + D$$

Rear axle load

Calculating the **actual rear axle load**

$$\text{Rear axle load in kg} = \text{actual total weight} - \text{actual front axle load}$$

Tyre load-bearing capacity

Data on the tyre load-bearing capacity of the front and rear tyres can be found in the tyre manufacturer's documentation.

- The front tyre load-bearing capacity for two wheels is equal to twice the permissible tyre load-bearing capacity of a single front wheel.
- The rear tyre load-bearing capacity for two wheels is equal to twice the permissible tyre load-bearing capacity of a single rear wheel.

Summary

Check if the following conditions are met:

- The actual rear axle load is less than the permissible values for the axle load stated in the operating manual of the carrierer vehicle
- The actual total weight is less than the permissible values for the total weight stated in the operating manual of the carrierer vehicle
- The sum of the permissible rear wheel load capacity is higher than the real rear wheel load capacity
- The sum of the permissible front wheel load capacity is higher than the real front wheel load capacity

If all conditions are met, the machine may be attached to this carrier vehicle.



You can use a sufficiently large weigh-bridge to determine the total weight, the rear axle load and the front axle load by weighing.

Road transport

Make sure that the condition of the machine conforms to road traffic regulations

The machine must conform to current traffic regulations if you intend to drive it on public roads. This includes for example:

- Fitting lighting equipment, warning devices and protective devices
- Observing the permissible transport widths, transport weights, axle loads, tyre load-bearing capacity and total weights

The driver and owner of the vehicle are liable if traffic regulations are not observed.

Closing ball valves

If ball valves are provided on the hydraulic lines or the chassis cylinders, the ball valves must be closed for road transport. Accidental actuation of control devices on the tractor might otherwise cause movements in the machine. Accidents or damage to the machine may be caused as a result.

Check release cable for the quick-release coupling

Release cables must hang loose and must not, when in their lowered position, release the couplings of their own accord. Attached machines might otherwise come loose from the three-point linkage of their own accord.

Riding on the machine is strictly prohibited

People or objects must never be transported on the machine. Riding on the machine poses a risk to life and limb and is strictly prohibited.

Take altered driving and braking behaviour into account

Driving and braking performance is altered when the machine is attached to the tractor. Take the width and balancing weight of the machine into consideration, especially when cornering. A driving style which not adjusted to the road conditions can lead to accidents.

Drive at a suitable speed

Always adjust your driving speed to the road conditions. Driving at excessive speeds in poor road conditions may create extremely large forces, which will severely load or overload the tractor and the machine. Driving at unsuitable speeds can cause machine damage and lead to accidents.

Training required before commissioning

The machine must not be put into operation until the user has been given proper training by an employee of the dealer, a factory representative, or an employee of the manufacturer. Commissioning without training can lead to damage to the machine due to false operation or accidents can happen.

Ensure that the machine is in perfect working condition

Do not operate the machine unless it is in perfect working condition. Check all important components and replace any defective components before starting the machine. Defective components can cause damage to equipment and personal injury.

Putting the machine into operation

Do not remove the protective equipment

The protective equipment must not be removed or by-passed. Check all protective equipment before starting the machine. Unprotected machine parts can cause serious or fatal injury.

Riding on the machine is strictly prohibited

People or objects must never be transported on the machine. Riding on the machine poses a risk to life and limb and is strictly prohibited.

Height of the machine and overhead power lines

If a height of 4.00 m is exceeded when folding the machine in and out, the machine must not be folded in the vicinity of live overhead power lines. Danger of electrocution! Should the machine come into contact with a live overhead power line:

- Do not attempt to exit the tractor cabin
- Do not touch any metal parts on the tractor
- Do not create any conductive contact with the ground
- Warn all persons in the area not to approach the tractor or the machine
- Wait for help from professional emergency service personnel as power in the live overhead power line must first be switched off

Never climb onto the machine beneath live overhead power lines. The voltage can jump across even if the lines are not actually touching the machine.

Check the hazard area

Before driving off, folding out, and operating the machine and during operation, check its hazard area. Make sure that you have an adequate view. Do not begin work until the hazard area is cleared of any persons or objects. Information regarding the hazard area can be found in the corresponding chapter.

→ Chapter »Mulching«, Section »Mulching«, Page 62.

Parts could be ejected from the machine at high speed in certain circumstances. The hazard area, particularly in front of and behind the machine, must be cleared of any persons, animals or objects before starting.

Any use of the machine without verification of the hazard area can lead to serious or fatal accidents.

Retighten all nuts, bolts and screws

Nuts, bolts and screws should be checked at regular intervals and tightened if necessary. Screws can come loose unnoticed while operating. Damage to the machine or accidents may be caused as a result.

What to do in the event of a fault

In the event of a malfunction, shut down and secure the machine immediately. The fault may be eliminated immediately, or a specialist workshop must be assigned the task. Further operation of the machine can lead to damage to the machine or injury to persons.

Uncoupling the machine

Increased risk of injury

There is an increased risk of injury when uncoupling the machine from the tractor. Therefore:

- Secure the tractor against rolling away
- Never stand between the tractor and the machine during uncoupling
- Actuate the three-point power lift system slowly and carefully
- Make sure the machine is standing on a secure and level surface
- Do not disconnect hydraulic hoses until there is no pressure in the tractor and machine hydraulic system

Failure to observe these instructions can result in serious or fatal injury.

Care and maintenance

Observe the care and maintenance intervals

Observe prescribed intervals for maintenance checks and inspections specified in the operating manual. If these periods are not observed, this can lead to damage to the machine, poor quality of work or accidents.

Use original replacement parts

Many components have special properties that are essential for the stability and correct operation of the machine. Unsuitable spare parts or accessory parts or incorrectly performed repairs or changes can cause damage to the machine, accidents or serious injury.

Müthing strongly recommends using only approved original Müthing accessories and spare parts. Müthing can guarantee the safety, reliability and suitability of these parts only.

Use of non-original Müthing spare parts shall invalidate any warranty claims.

When performing any care and maintenance work:

- Switch off the PTO stub shaft
- Depressurise the hydraulic system
- Whenever possible, uncouple the tractor
- Make sure the machine is standing securely. Provide additional support as required
- Do not use parts of the machine as climbing aids; use only secure steps, ladders or other means of access
- Secure the machine against rolling away
- Never reach into the V-belt while it is moving

It is only possible to guarantee work safety during care or maintenance work through observing these regulations.

Turn off the electrical supply

Prior to carrying out work on the electrical system, disconnect the system from the power supply. Systems supplied with electrical power can cause damage to equipment and personal injury.

Replace hydraulic hoses

Replace hydraulic hoses every six years. Hydraulic hoses can age without any externally visible damage. Defect hydraulic lines can lead to severe or fatal injuries.

Caution when cleaning with a high-pressure cleaner

The machine can be cleaned using either water or a steam jet. Only use a low pressure to clean bearings, fans, signal mixer units, plastic parts and hydraulic hoses. Excessively high pressures can cause damage to these parts.

Before carrying out welding work, disconnect the battery and alternator

Before carrying out any electric welding work on the attached machine, disconnect the tractor battery and the alternator. This avoids damage to the electrical system.

Tighten all screwed connections

All screw connections that are released during maintenance and repair work must now be retightened. Loose screwed connections can cause bolts to undo without you noticing during your work. As a result, machine parts can become detached. Otherwise, this may result in severe injury or damage to equipment.

Further regulations

Observe the regulations

In addition to these safety instructions, observe the following:

- Accident prevention regulations
- Generally recognised safety regulations, occupational health requirements and road traffic regulations
- Information and instructions in this operating manual
- Operation, maintenance and repair instructions

Familiarising yourself with the machine

This chapter contains general information on your machine as well as information on:

- Range of application
- Features
- Designation of components
- Technical specifications

Range of application of the machine

The machine may only be used for its intended agricultural or associated purpose, depending on the type of tool with which it is equipped.

Tool	Purpose
Hammer flail	To cut grass, other growth or sections up to a maximum of 5 cm diameter

Since the conditions of use are very varied, the user must pay particular attention to the machine's performance limits. The machine must be switched off immediately if there is any indication of overstress.

Proper use

The machine should only be used for the designated work as described in this operating manual. Any application other than or beyond this is considered improper use.

Examples of improper use:

- Transporting persons or objects
- Cutting of any products other than those specified or those of a similar nature

→ »Range of application of the machine«

- Transferring power to other objects
- front attachment
- Working depths under 25 mm clearance from ground
- Any type of ground work
- Use of the machine in a position in which the tools do not point towards the ground, for example in a vertical position

The manufacturer and dealers are not liable for damage caused by improper use. The risk is borne solely by the user.

Familiarising yourself with the machine

Features of the machine

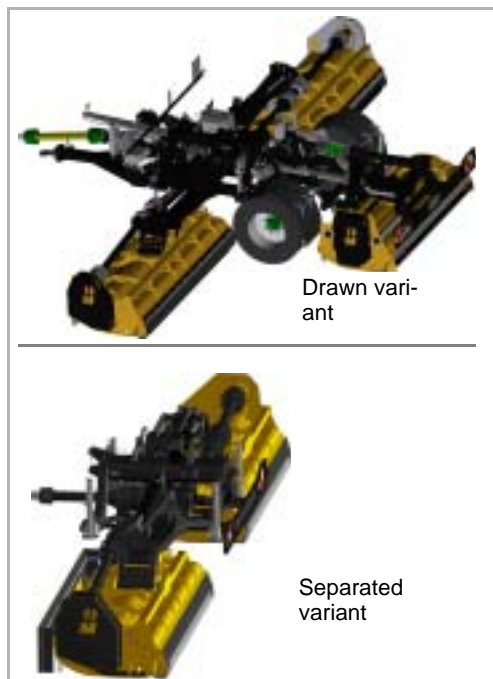

Robust housing in optimised form

The housing is particularly robust for heavy use and is designed in an optimised form.

Configuration

The machine can be used in two configurations:

- Drawn variant: Three mulchers are mounted on the machine and are drawn behind the tractor. The machine has an axle with two wheels.
- Separated variant or “butterfly” combination: Two mulchers are mounted on the machine and are drawn behind the tractor. An additional mulcher is mounted on the front of the tractor.

Power transmission

Power is transmitted to a gear box via a PTO shaft. From there, the rotor is driven via V-belt.

MU-SOFA®

The machine adjusts itself optimally to the soil conditions with a hydro-pneumatic weight transfer system. The weight transfer system is integrated into the on-board hydraulics.

Safety

The machine is constructed in accordance with EU regulations, for maximum possible safety of operation. The machine bears the CE mark and the UKCA mark.

Braking system [+]

The drawn machine is equipped with an air brake system.

Familiarising yourself with the machine

Designation of components

Designation of the assemblies for the installed mulcher:
→ Mulcher operating manual

Drawn variant

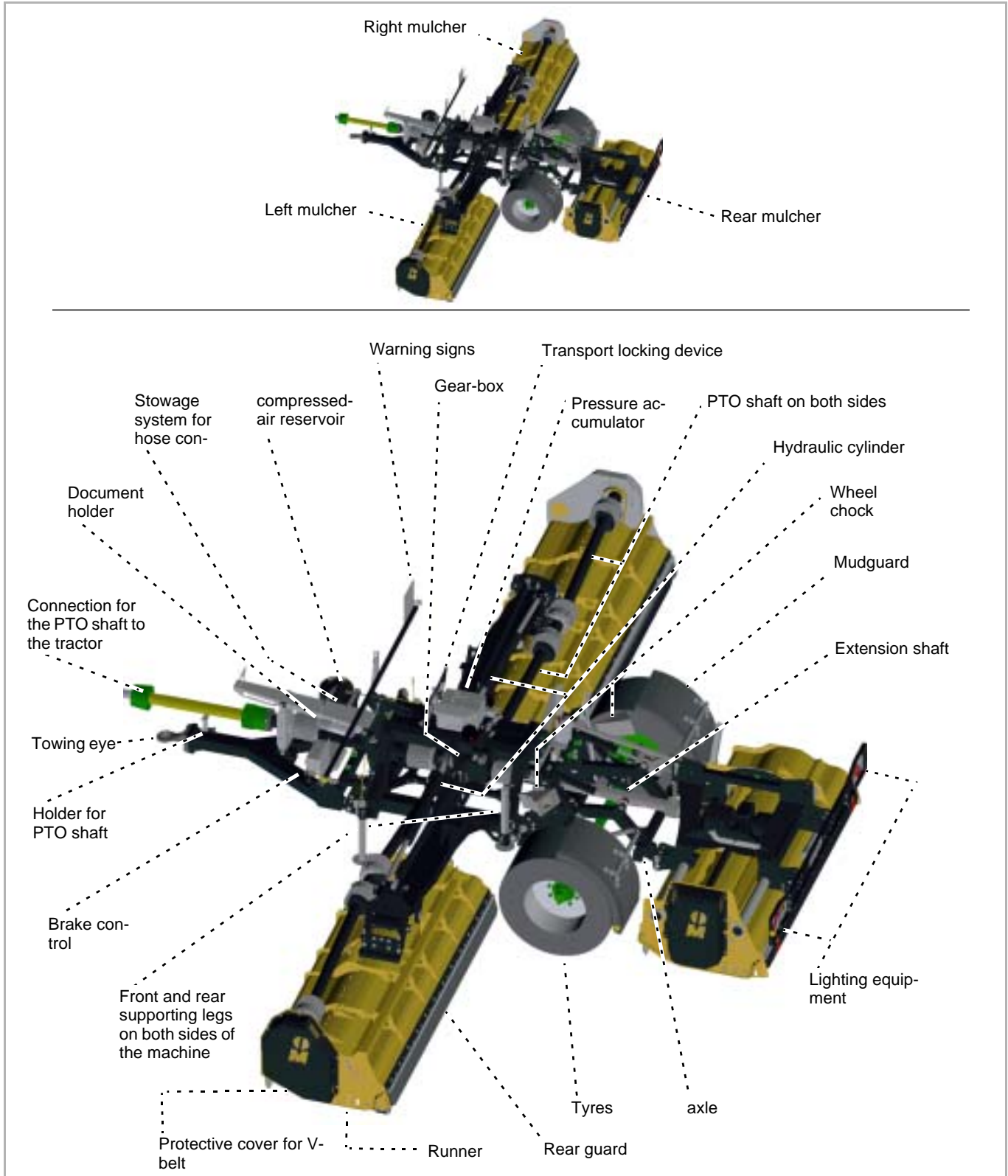

Familiarising yourself with the machine

Separated variant

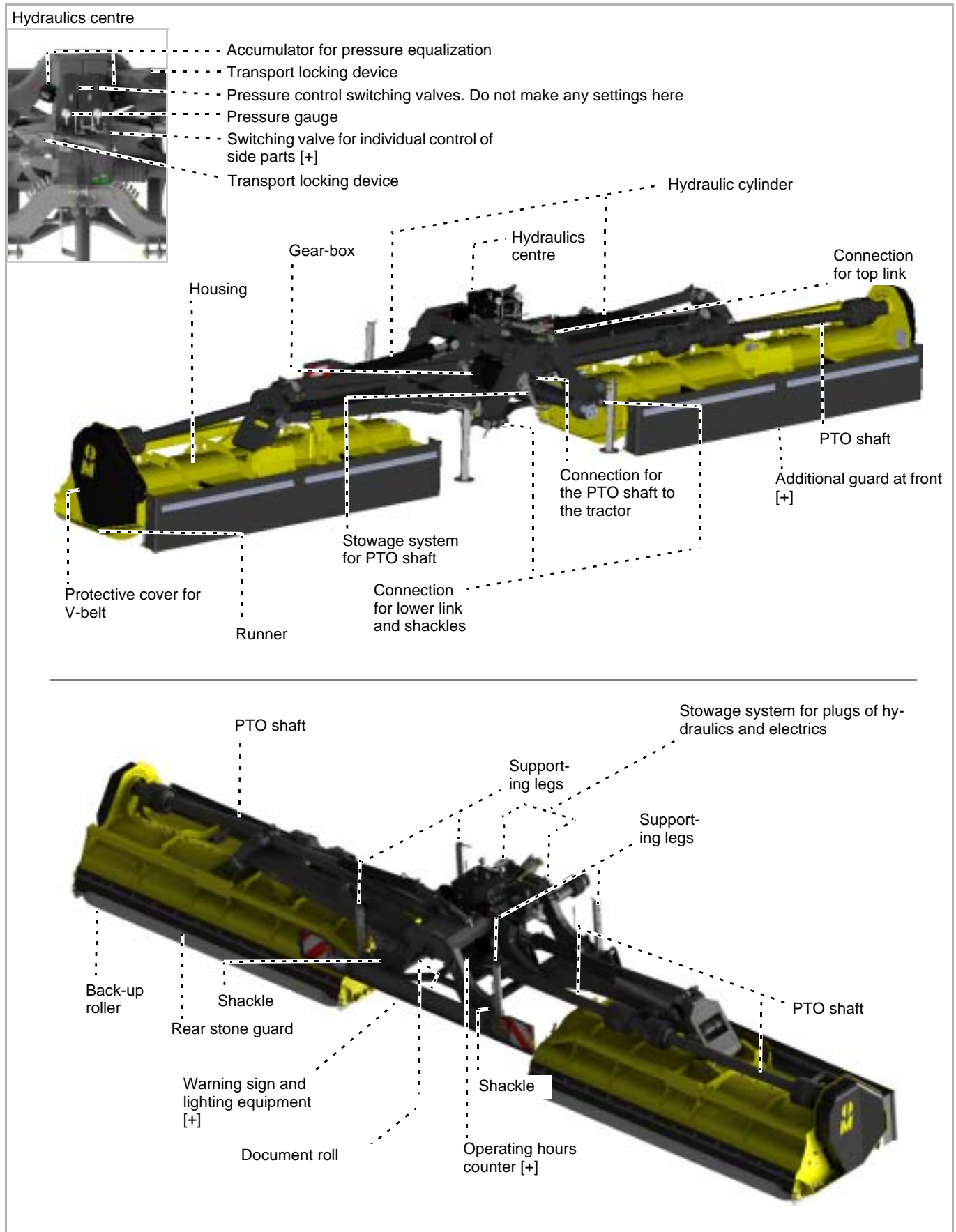

Familiarising yourself with the machine

Technical specifications

Drawn variant

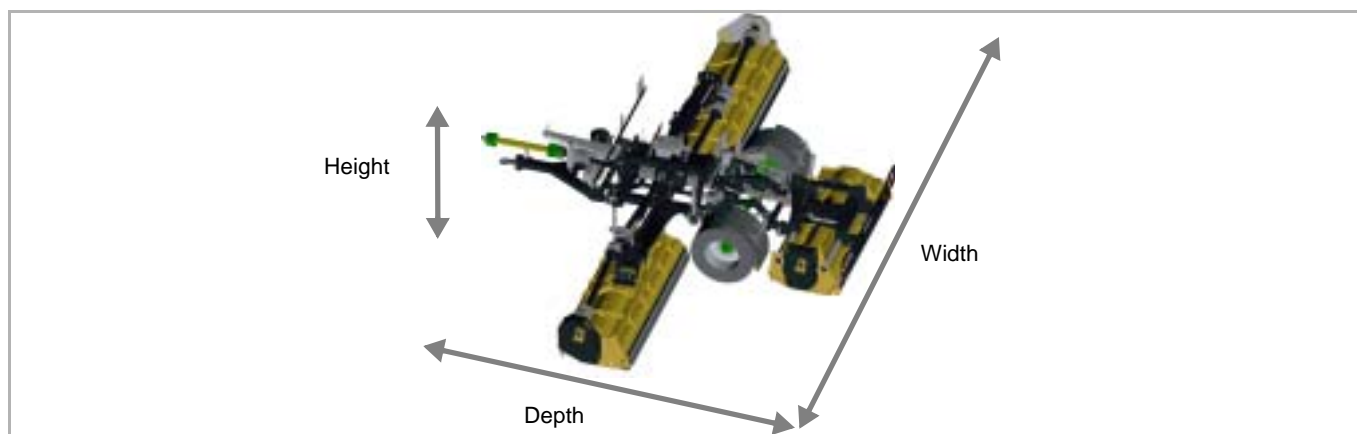

	MU-PRO/F Trail
Height [m]	
In work position	1,70
In transport position	3,99
Width [m]	
In work position	8,99
In transport position	2,99
Depth [m]	
In work position	6,48
In transport position	6,48
Working width [m]	
In work position	8,6
Total weight [kg]	
Depending on equipment level, approx.	6500
Centre of gravity (dimension G)	
From centre of coupling	4150
Rotational speed of rotor [rpm]	
PTO stub shaft 1000 rpm	2100
Power demand [kW/HP]	
Minimum	147/200
Maximum permitted	368/500
Tractor weight [kg]	
Minimum	7000
Working depth [mm]	
Infinitely variable	25/49/73
Number of tools	
M-hammer flail	80
Lubricants	
Transmission oil	SAE 75W-90
hydraulic oil	HLP46

Familiarising yourself with the machine

	MU-PRO/F Trail
Category	
Lower link	IV + K80 + Hitch + Piton Fix
Paint colors	
Yellow	RAL 1007
Black	RAL 9005
PTO shaft	
Model	GE2802, GE2803
Noise emission [dB(A)]	
In the workplace	< 80

Familiarising yourself with the machine

Separated variant

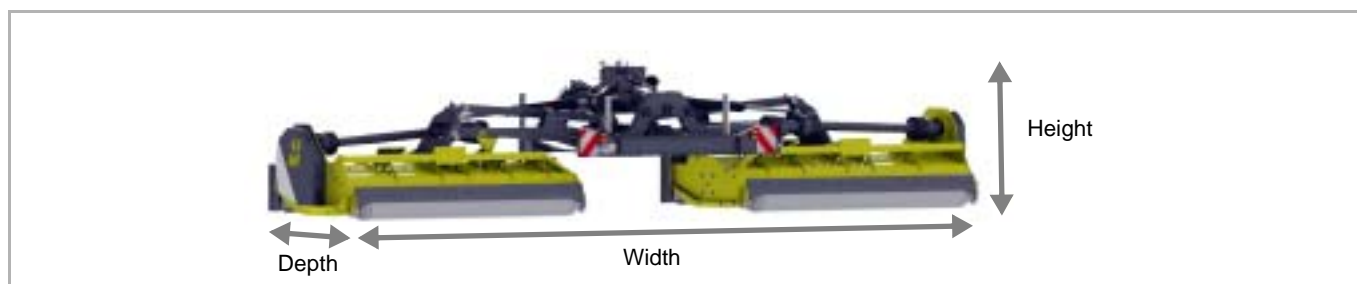

MU-PRO/F 860	
Height [m]	
In work position	1,57
In transport position	3,55
Width [m]	
In work position	8,99
In transport position	2,88
Depth [m]	
In work position	1,71
In transport position	1,71
Working width [m]	
In work position	8,6
Total weight [kg]	
Depending on equipment level, approx.	3590
Centre of gravity (dimension G)	
Rear attachment	815
Rotational speed of rotor [rpm]	
PTO stub shaft 1000 rpm	2100
Power demand [kW/HP]	
Minimum	147/200
Maximum permitted	298/400
Tractor weight [kg]	
Minimum	7000
Working depth [mm]	
Infinitely variable	59/49/73
Number of tools without a front-mounted machine	
M-hammer flail	56
Lubricants	
Transmission oil	SAE 75W-90
hydraulic oil	HLP46

Familiarising yourself with the machine

	MU-PRO/F 860
Category	
Lower link	III + IV
Paint colors	
Yellow	RAL 1007
Black	RAL 9005
PTO shaft	
Model	GE2601, GE2602, GE2603
Noise emission [dB(A)]	
In the workplace	< 80

Checking the scope of delivery

The machine is delivered completely assembled. If parts of the machine have not been assembled, please contact your dealer.



Do not assemble the machine yourself

Do not perform assembly work yourself since requirements for an orderly condition of the machine are :

- Observance of a sequence of worksteps
- Compliance with tolerances and torques

Incorrect assembly may result in damage to the machine or poor performance.



If parts are missing or have been damaged during transportation, please submit a claim immediately to your dealer, importer or the manufacturer.

Coupling the machine



Increased risk of injury

When the machine is being coupled to the tractor, there is an increased risk of injury. Therefore:

- Secure the tractor against rolling away
- The tractor and machine must belong to the same category
- Never stand between the tractor and the machine during coupling
- Actuate the three-point power lift system slowly and carefully

Failure to observe these instructions can result in serious or fatal injury.



Only attach the machine to the rear

The machine may only be attached to the rear of the tractor.
The tractor and machine can be damaged if front-mounted.

Drawn variant

The machine can be set down in the work position or in the transport position.

Coupling

The machine can be set down in the work position or in the transport position. The operation steps for coupling to the tractor are identical for the work position and the transport position. The pictures below show the machine in the work position.

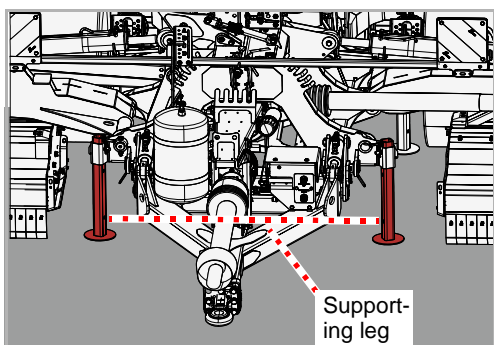

Prerequisites for coupling:

- The machine is safely set down. The front supporting legs have been lowered.
- Chapter »Parking and storage« paragraph »Setting down the machine in a secure position«, page 71

If the machine is not securely parked:

- ▶ Secure the machine with suitable lifting gear and move into the correct position



The machine can be equipped with a lower link receiver, towing eye, hitch ring or towing ball. The pictures below show the machine with a towing eye.

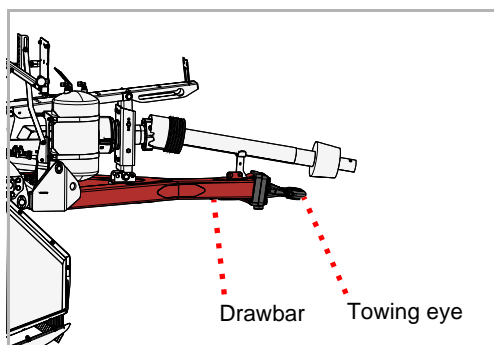

- ▶ Drive the tractor slowly backwards to the machine and couple the machine
- ▶ Ensure that the locking devices engage securely on the coupling
- ▶ Secure the tractor against rolling away

Coupling the machine

- ▶ Raise the machine slightly
- ▶ Remove split pin at pin
- ▶ Pull out the pins

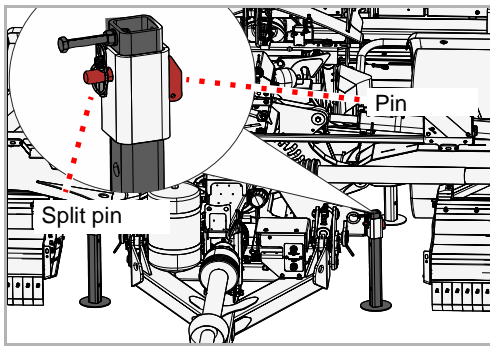

- ▶ Push supporting leg upwards and secure in top position with pin and split pin
- ▶ Secure second supporting leg also in upper position

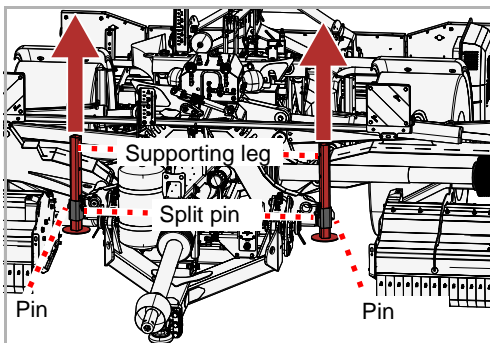

If the machine is secured with wheel chocks:

- ▶ Remove wheel chocks from wheels on both sides
- ▶ Place wheel chocks into holder

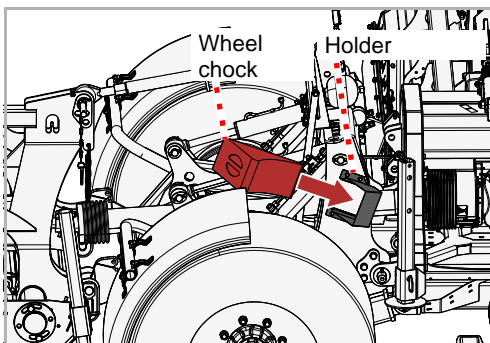

PTO shaft

The PTO shaft has been adjusted to fit your tractor by your dealer.

Machine side

Generally, the PTO shaft is already connected to the machine. If the PTO shaft is replaced or after maintenance work to the PTO shaft, it will be necessary to connect it to the machine.

- ▶ Carefully clean and grease the PTO shaft and connection to the machine
- ▶ Slide propeller shaft onto connection on machine and secure with clamp screw

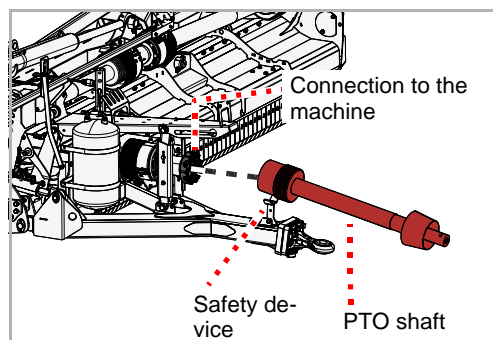

Coupling the machine

Tractor side



If the tractor is changed, the correct length of the PTO shaft must be checked. It is particularly important when checking the PTO shaft to ensure that the two halves of the PTO shaft continue to overlap at the position in which the PTO shaft is pulled apart furthest.

Please pay particular attention to the following points in the operating manual for the PTO shaft:

- Shortening the PTO shaft
- Maintenance
- Required grease quantity
- Care of PTO shaft

When changing the tractor, check that the PTO shaft is suitable for this tractor and if necessary, replace the PTO shaft and have it adjusted at a qualified specialist workshop.

Connection

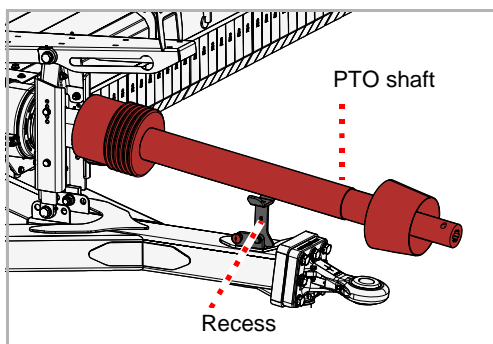

- ▶ Raise the PTO shaft slightly and take it out of its stowage system



Do not lay the attached PTO shaft on the stowage system

The attached PTO shaft must not be in the stowage system.

A PTO shaft in the stowage system will be damaged during road transport.

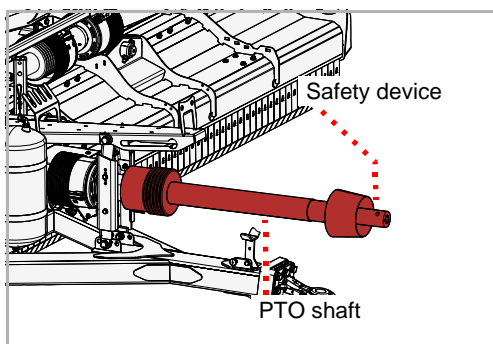

- ▶ Connect the PTO shaft to the tractor's PTO stub shaft and ensure that the retainer is locked in place on the PTO shaft

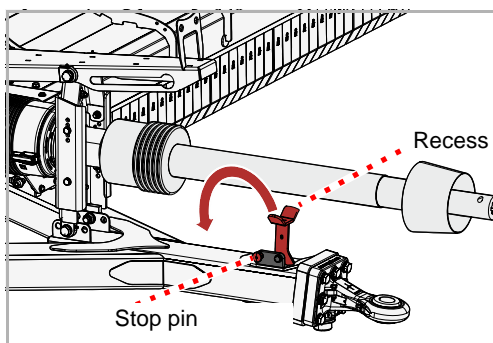

- ▶ Pull out locking bolt
- ▶ Fold in stowage system and allow locking bolt to engage

Separated variant

The machine can be set down in the work position or in the transport position.

Coupling

The machine can be set down in the work position or in the transport position.

Work position

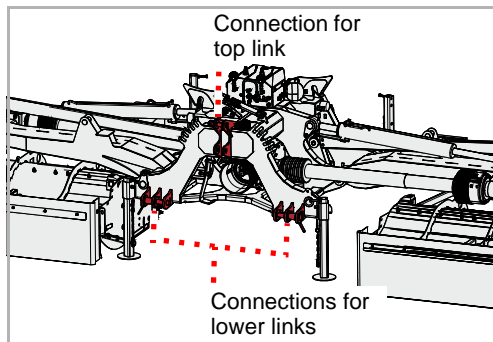
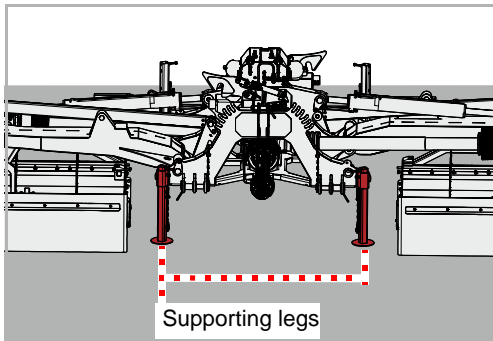

Prerequisites for coupling:

- The machine is safely set down. The machine is folded out into the work position and the front and rear supporting legs are lowered.
- Chapter »Parking and storage« paragraph »Setting down the machine in a secure position«, page 71

If the machine is not securely positioned:

- ▶ Secure the machine with suitable lifting gear and move into the correct position

Attachment can be performed on tractors with connections for lower links of category III or category IV.

- ▶ Adjust both lower links on the tractor to the same height
- ▶ Connect the lower link according to the category of tractor and secure with linchpin
- ▶ Connect the top link according to the category of tractor and secure with linchpin

Coupling the machine

Supporting legs

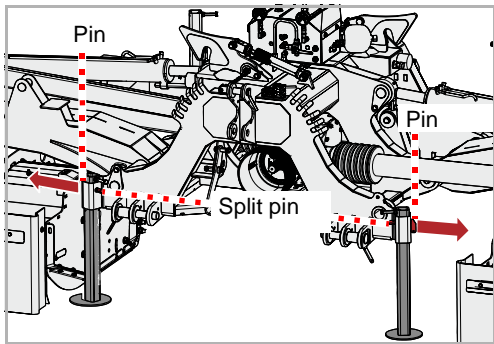

- ▶ Raise the machine slightly
- ▶ Remove split pins at pins
- ▶ Pull out the pins

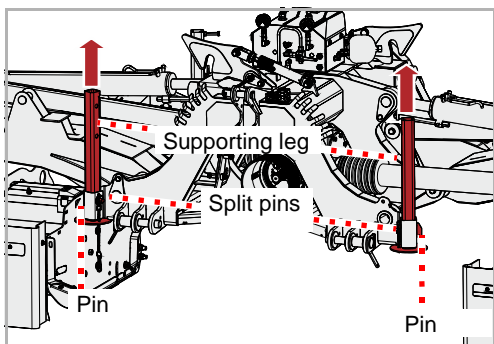

- ▶ Push supporting leg upwards and secure in top position with pins and split pins

Transport position

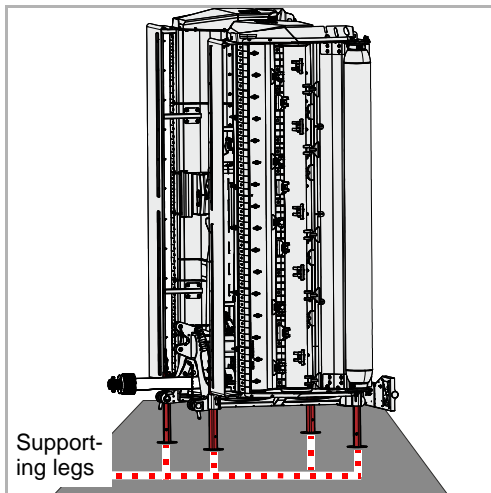

- ▶ Check that the machine is securely positioned. The machine is folded into the transport position and the front and rear supporting legs are lowered.

→ Chapter »Parking and storage«, section »Setting down the machine in a secure position«, from page 71

If the machine is not securely positioned:

- ▶ Secure the machine with suitable lifting gear and move into the correct position

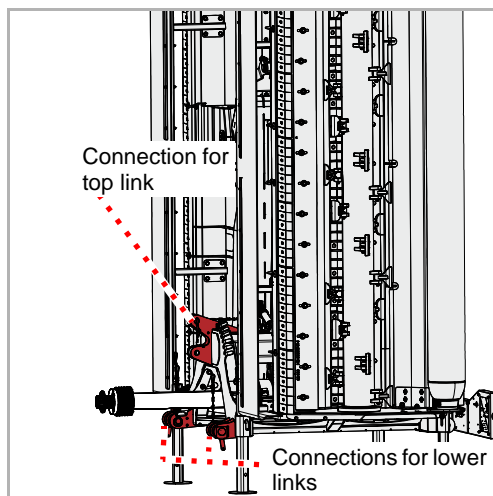

Attachment can be performed on tractors with connections for lower links of category III or category IV.

- ▶ Adjust both lower links on the tractor to the same height
- ▶ Connect the lower link according to the category of tractor and secure with linchpin
- ▶ Connect the top link according to the category of tractor and secure with linchpin

Supporting legs

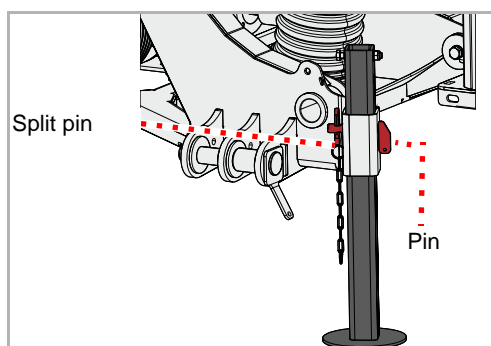

- ▶ Raise the machine slightly
- ▶ Remove split pin at pin
- ▶ Pull out the pins
- ▶ Push supporting leg upwards and secure in top position with pin and split pin

Also secure the remaining 3 supporting legs in the upper position

Coupling the machine

Lower link

- ▶ Adjust the lower link so that the machine has little play to the left or right

Top link

Work position

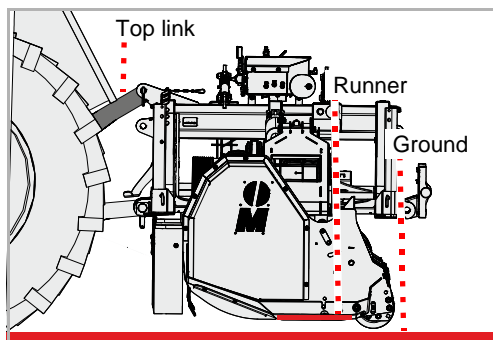

- ▶ Adjust the top link so that the runners are parallel to the ground

Transport position

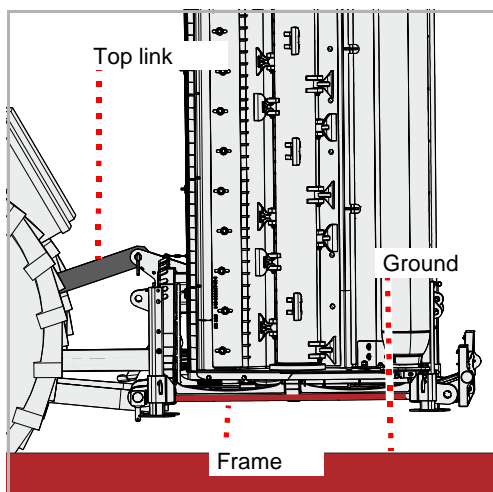

- ▶ Adjust the top link so that the frame is parallel to the ground

PTO shaft

The PTO shaft has been adjusted to fit your tractor by your dealer.

Machine side

Generally, the PTO shaft is already connected to the machine. If the PTO shaft is replaced or after maintenance work to the PTO shaft, it will be necessary to connect it to the machine.

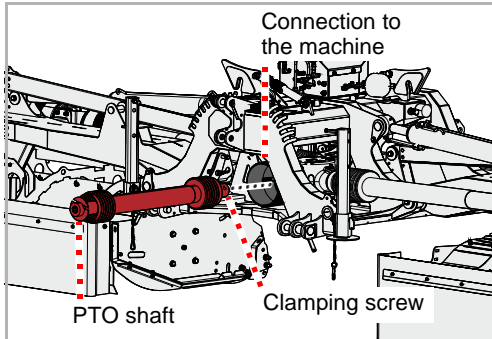

- ▶ Carefully clean and grease the PTO shaft and connection to the machine
- ▶ Slide propeller shaft onto connection on machine and secure with clamp screw

Tractor side



If the tractor is changed, the correct length of the PTO shaft must be checked. It is particularly important when checking the PTO shaft to ensure that the two halves of the PTO shaft continue to overlap at the position in which the PTO shaft is pulled apart furthest.

Please pay particular attention to the following points in the operating manual for the PTO shaft:

- Shortening the PTO shaft
- Maintenance
- Required grease quantity
- Care of PTO shaft

When changing the tractor, check that the PTO shaft is suitable for this tractor and if necessary, replace the PTO shaft and have it adjusted at a qualified specialist workshop.

Coupling the machine

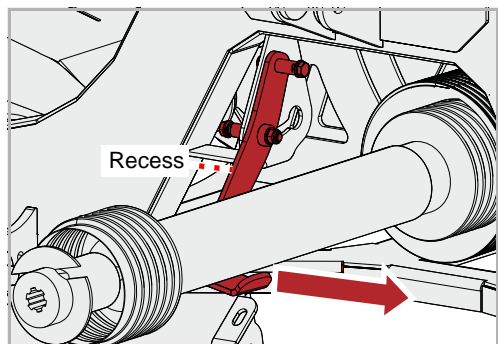

- ▶ Lift propeller shaft and pull stowage system to the right

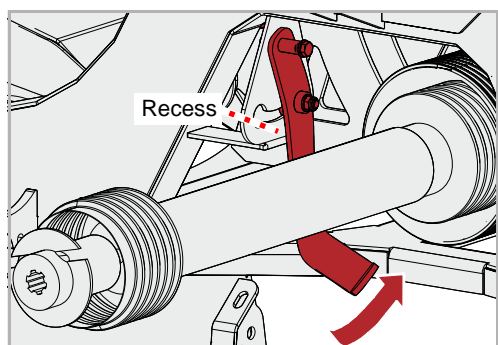

- ▶ Swivel the stowage system into the rear position and make sure that the stowage system locks into place



Do not lay the attached PTO shaft on the stowage system

The attached PTO shaft must not lie in the stowage system.

A PTO shaft lying in the stowage system will be damaged during road transport or when operating the lower link.

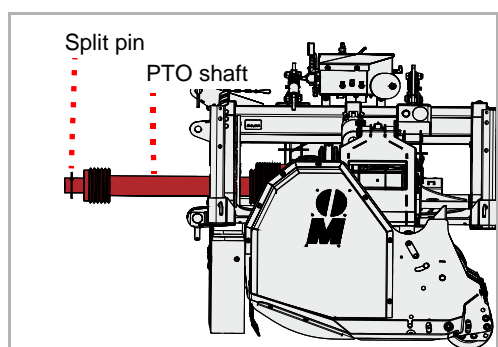

- ▶ Connect the PTO shaft to the PTO stub shaft of the tractor and ensure that the cotter pin is locked in place on the PTO shaft

Hydraulics

Drawn variant



The following functions can be controlled:

Function	Color of dust cap	control valve	Number
Fold machine from headland position to transport position	Blue [+]	Double-acting	1
Fold machine out of transport position to headland position	Blue [-]		
Unlock transport locking device and raise frame	Black [+]	Double-acting	2
Lock transport locking device and lower frame	Black [-]		
Lift drawbar	Green [+]	Double-acting	3
Lower drawbar	Green [-]		
Move rear flail mower to right or left	Yellow [+/-]	Double-acting	4
Lift flail mower to headland position and lower flail mower to work position	Red [+]	Single-acting	5
Individual control [+]: Lift single left flail mower to headland position and lower single left flail mower to work position	Orange [+]	Single-acting	6
Retract or extend cutting bar	Purple [+/-]	Double-acting	7

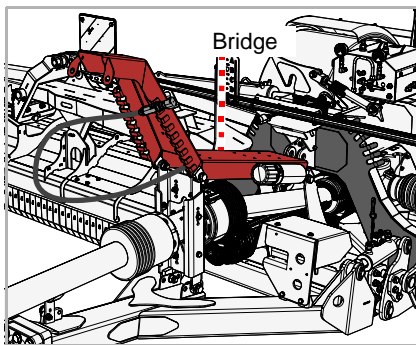

Check that all hydraulic hoses are correctly routed. The hydraulic hoses should be routed under the bridge.

- ▶ Connect hydraulic connectors to corresponding control valves

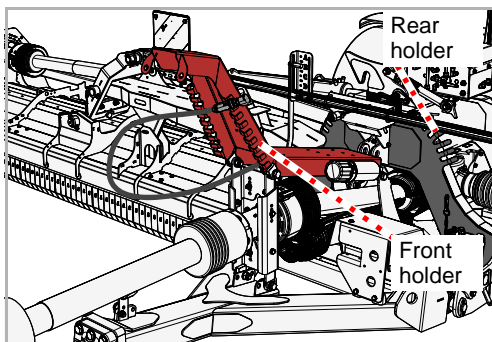

If not all connections are required:

- ▶ Place the hydraulic connectors that are not connected to the tractor only in the front holder. You thus avoid breaking off the hoses during road transport or while working. Do not leave hydraulic connectors in the rear holder.

Coupling the machine

Separated variant

The following functions can be controlled:

Function	Color of dust cap	control valve	Number
Fold machine in or out	Blue [+] [-]	Double-acting	1
Unlock and lock transport locking device	Black	Single-acting	2
Lift flail mower to headland position and lower flail mower to work position	Red [+]	Single-acting	5
Individual control [+]: Lift single left flail mower to headland position and lower single left flail mower to work position	Red [+] [+]	Single-acting	6

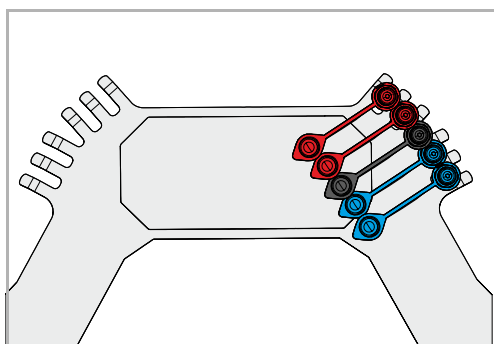

- ▶ Connect hydraulic hoses to corresponding control valves on tractor

Electrics

Attach the plugs to the tractor for:

- The lighting equipment on the machine
- ▶ Check that the lighting equipment is working correctly

For indicators which are not signalling and are equipped with LEDs:



Depending on the tractor, the tractor's electrics may require regrouping in the electrical cable's plug connection. Please contact your dealer in this case.

Compressed air

The pneumatic brake system of the machine is designed as a dual-line system.

For transport purposes, the machine must always be attached to a tractor with an appropriate air brake system.

Without compressed air, the brakes are mechanically locked. In an emergency, the brakes can be released with a special tool.

Function	Hose colour
Control circuit	Yellow
Air supply line	Red



Do not perform road transport without braking effect

Do not perform road transport if there is no braking effect. The machine cannot brake and loads or overloads the braking effect of the tractor.

Driving without braking effect can result in accidents.

Do not drive with manual braking effect

Before every drive, check that the brakes are released and that the manual braking effect is not switched on. Driving with engaged brakes can destroy the brakes and cancel the braking effect.

Driving without braking effect can result in accidents.

Use adequately dimensioned tractors for manoeuvring without braking effect

The tractor performing the shunting manoeuvre must be able to brake the unbraked machine at any time.

Serious accidents can result if the tractor is unable to brake the machine.

Coupling the machine

Connection to the tractor

Connect the air brake system with two hoses to the tractor:

- Air supply line with red marks
- Control line with yellow marks

- ▶ Secure the tractor against rolling away
- Tractor operating manual

- ▶ Connect the air supply line and the control line
- ▶ Check hoses for tight seating

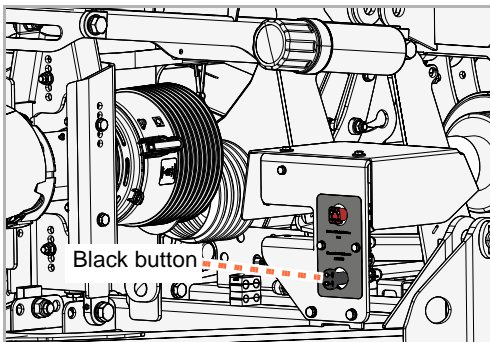
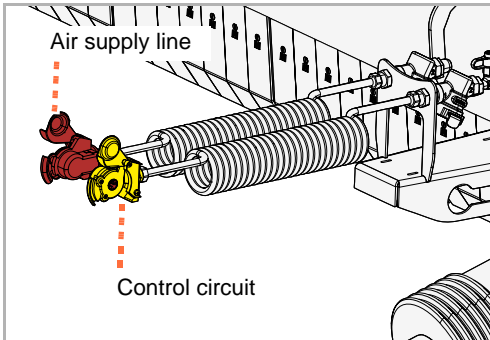

- ▶ Fill the system with air from the tractor until the pressure relief valve is triggered on the tractor.
The black knob adjusts to the upper position
The brake system is now operational.

Manual braking

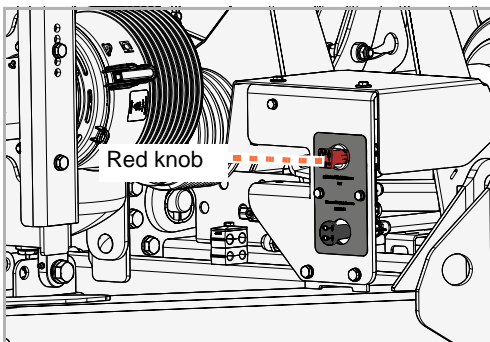

- ▶ Pull out the red knob to the upper position

Cancelling the manual braking effect:

- ▶ Press red knob down again to the lower position

Cancelling braking effect



You can remove the braking effect using the special tool supplied.

Only cancel the braking effect in an emergency

The braking effect must only be cancelled in an emergency. Road transport with cancelled braking effect is not permissible under any circumstances.

Driving without braking effect requires special attention by the operator and can result in accidents.

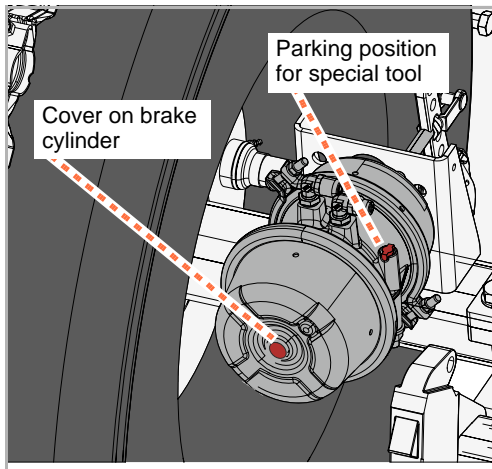

- ▶ Remove special tool from parking position. This requires a spanner, 24
- ▶ Open cover on brake cylinders
- ▶ Insert special tool and turn until it locks
- ▶ Turn the nut with the spanner until the braking effect is removed. The braking effect stays removed for as long as the special tool is screwed in.



The braking effect must be restored again as quickly as possible.

Restore braking effect

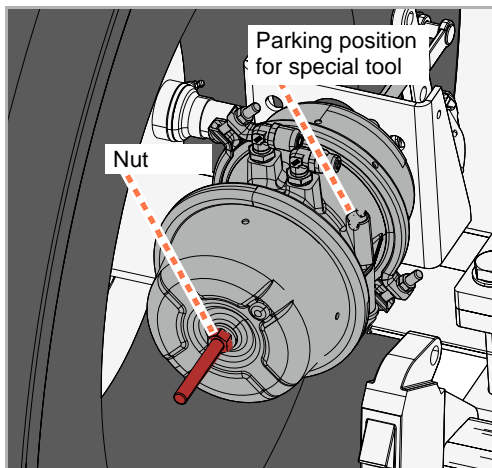

- ▶ With the spanner, 24
- ▶ Turn the special tool until it can be removed
- ▶ Secure special tool in the parking position
- ▶ Close the openings on both brake cylinders with the covers

Preparation

Working width

The working depth setting depends on where the cut material is deposited.

Depositing cut material behind the support roller

The working depth can be adjusted in three stages. The optimal working depth for most applications is the middle setting.

Depositing cut material in front of the support roller

The working depth can be set at one of two levels. The working depth can be set to 25 mm or 49 mm.

adjustment



Tools must not come into contact with the ground

Any contact with the ground could result in stones or other material not being held back safely by the stone guard.

Persons even outside of the hazard area could be injured by ejected material.



Check the number of bolts

The working depth setting must be secured with two bolts on the adjustment side.

If only one bolt is used on the adjustment side, the machine may be damaged by excessive wear.

► Fold out the machine

→ Chapter »Mulching« paragraph »Folding out«, page 63

Tools

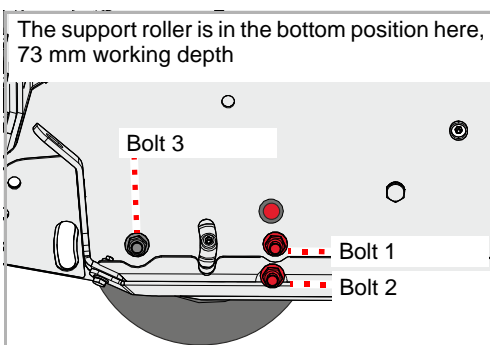
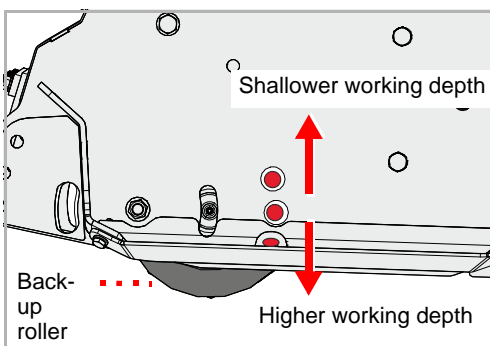
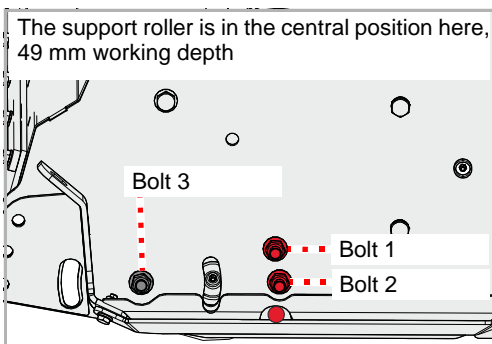
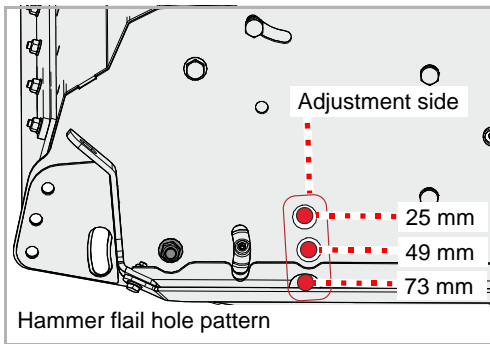

The working depth setting depends on the type of tool.

Tool	Possible working depths [mm]		
Hammer flail	25	49	73

Set the working depth using the centre hole in the support roller.

- ▶ Secure the tractor against rolling away
- ▶ Raise the machine approximately 5 cm

- ▶ Undo and remove bolts [1] and [2]
- ▶ Loosen bolt [3]

- ▶ Raise or lower the machine so that it is at the desired working depth. Pay attention to the centre hole of the support roller while doing this. The centre hole must be in the position in the hole pattern in which the required working depth can be set.

- ▶ Insert and tighten bolts [1] and [2]
- ▶ Retighten bolt [3]
- ▶ Make the same adjustment on the opposite side of the housing.

Preparation

Drawn variant

Display

There are two indicators on the machine for orientation. You can thus conveniently restore an optimal work position that you found previously.

Prerequisites for adjustment:

- Machine is standing on a flat surface
 - Machine is folded out
 - The indicator on the two hydraulic cylinders is in the green range
- Chapter »Mulching« paragraph »Folding out«, page 63

Front

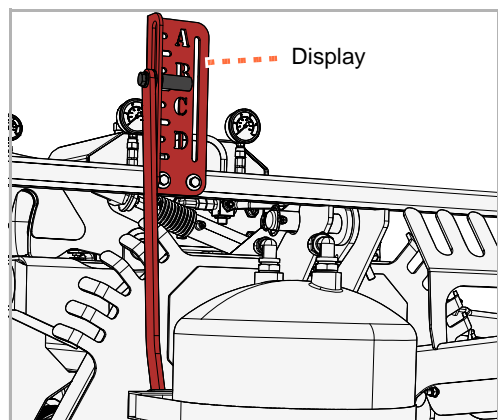

The "A-B-C-D" indicator shows the cutting level.

→ Chapter »Preparation« paragraph »Cutting level«, page 49

Rear

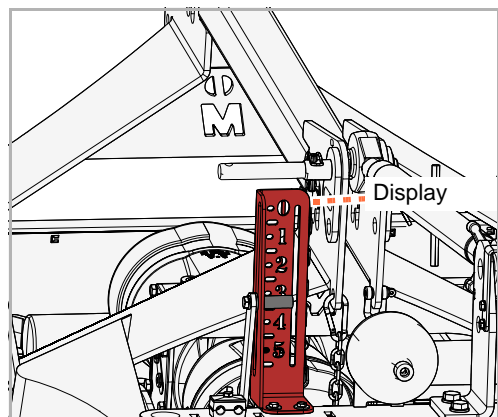

The "0-1-2-3-4-5" indicator shows the height of the frame above the ground.

Cutting level

You can adjust the cutting level hydraulically. The cutting level is the forward or rearward inclination of the flail mower.

- ▶ Fold out the machine
 - ▶ Lower the machine into the work position
- Chapter »Mulching« paragraph »Folding out«, page 63

Drawn variant

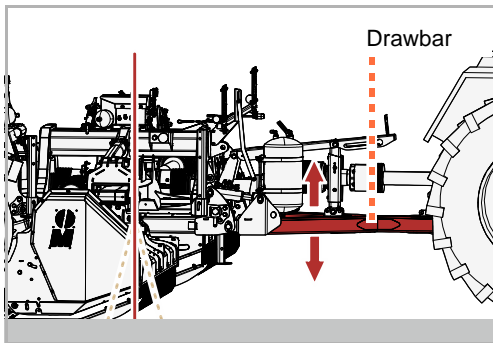

When you lift or lower the drawbar, you change the cutting level.

- ▶ Use the control unit on the tractor to lower or lift the drawbar

Separated variant

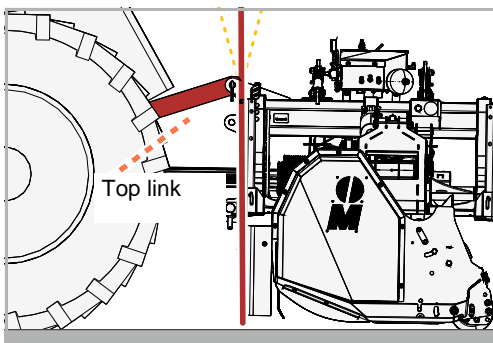

You can change the cutting level via the upper link.

- ▶ Lengthen or shorten upper link

Preparation

Mechanical cutting bar [+]

You can alter the degree of shredding using a cutting bar.



Check for contact between tools and the cutting bar

The tools must not be touching the cutting bar.

If any tools are touching the cutting bar, this will damage the tools in question and the cutting bar itself.

Adjusting

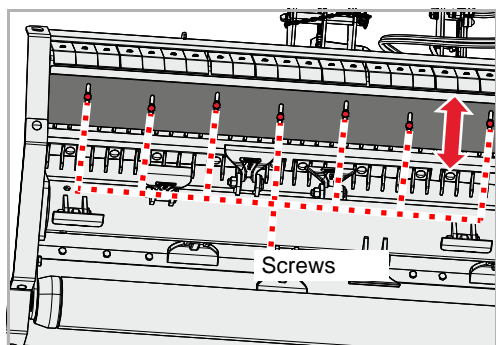

- ▶ Raise the machine and mechanically secure it against lowering
- ▶ Loosen the screws but do not remove them
- ▶ Move the cutting bar as required
- ▶ Retighten the bolts

Checking

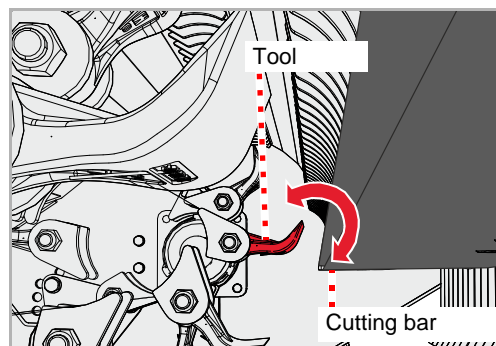

Check whether any of the tools are touching the cutting bar.

- ▶ Turn the rotor by hand until one tool is next to the cutting bar
- ▶ Move the tool next to the cutting bar back and forth

If the tool touches the cutting bar:

- ▶ Move the cutting bar away from the tools
- ▶ Continue turning the rotor by hand and check the rest of the tools along the entire length of the cutting bar.

Hydraulic cutting bar [+]

The hydraulic cutting bar is infinitely variable via the control unit on the tractor while driving.

Depositing cut material

Depending on the soil conditions, you can decide whether to deposit the cut material behind or in front of the support roller.

Use	Advantages	Disadvantages
On green areas Depositing behind the support roller	In normal soil conditions, the cut material is deposited behind the support roller. The support roller runs directly over the ground. The machine follows the contours of the ground precisely.	In poor soil conditions, the support roller becomes contaminated.
On field surfaces Depositing in front of the support roller	The cut material is deposited in front of the support roller. The support roller runs over the cut material, not directly over the ground. This reduces the level of contamination on the support roller.	The support roller presses the cut material on to the ground. The machine does not follow the contours of the ground as precisely as when using a standard support roller. You can only select two of the three working depths.

In front of the support roller

Depositing the cut material in front of the support roller is advantageous on field surfaces. In this position, the support roller runs over the cut material, not directly over the ground. The following preparations must be made to do so:

- Remove rear stone guard
- Swivel the support roller to the correct position
- Fit the scraper
- Swivel the guide plate to the correct position

Rear stone guard

Before conversion, you must remove the rear stone guard and fit the scraper.



Store all removed parts together in a safe place. Should you wish to convert the support roller again at a later date, you will need the parts you removed.

- ▶ Raise the machine slightly and secure it against lowering
- ▶ Undo all the nuts on the rail and remove them along with the washers
- ▶ Remove rail and rear stone guard

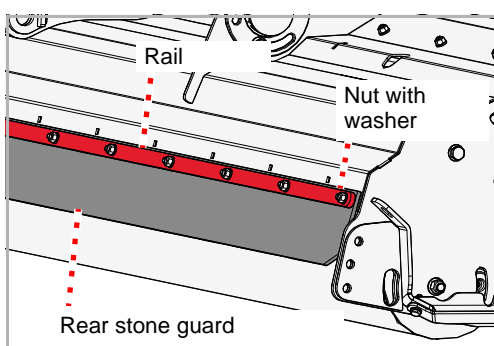

Preparation

Back-up roller

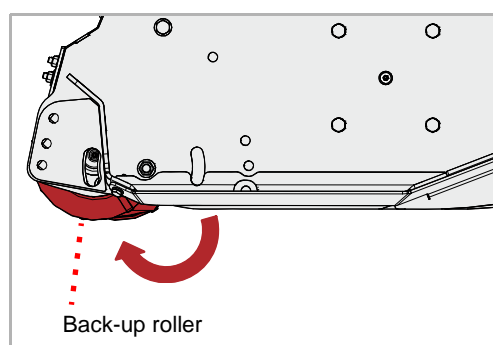
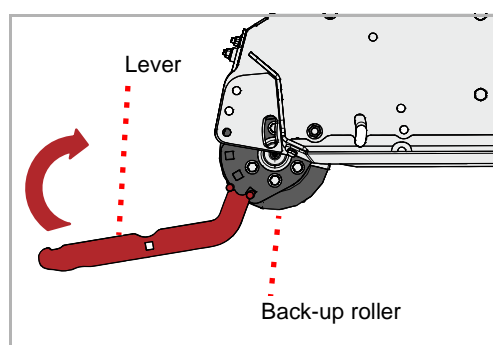
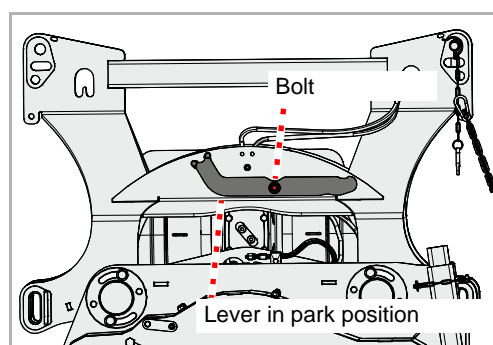
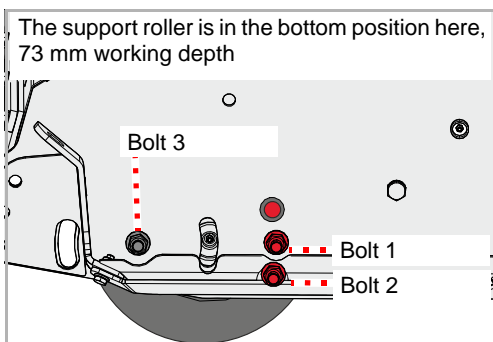

The support roller must be swivelled into the rear position.

- ▶ Undo and remove bolts [1] and [2]
- ▶ Also undo and remove bolts [1] and [2] on the opposite side of the housing
- ▶ Undo bolt [3]
- ▶ Also undo bolt [3] on the opposite side of the housing

The lever is located on the front-mounted flail mower

- ▶ Undo the bolt on the lever
- ▶ Move the lever out of park position

- ▶ Position the lever on the support roller

- ▶ Use the lever to swivel the support roller into the rear position

The support roller is in the central position here, 49 mm working depth

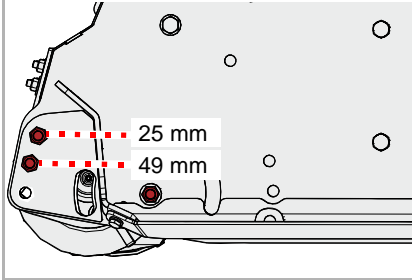

Set the working depth using the centre hole in the support roller. The working depth can be set to 25 mm or 49 mm.

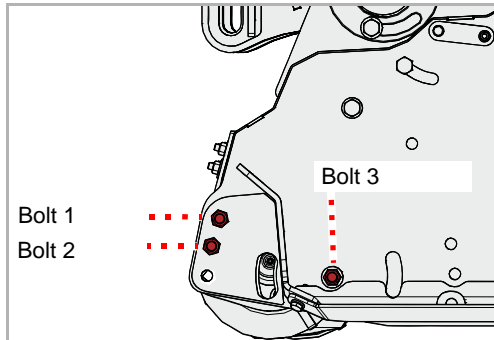

- ▶ Set the support roller to the required working depth and fix it in position using bolts [1] and [2]
- ▶ On the opposite side of the housing, use the lever to set the support roller to the required working depth
- ▶ Also fix the support roller in position using bolts [1] and [2] on the opposite side of the housing
- ▶ Tighten bolt [3]
- ▶ Also tighten bolt [3] on the opposite side of the housing

Scraper

The scraper should be set so that the clearance between it and the support roller is 3-5 mm. If the scraper is worn, or if you have fitted it on the extension support roller, it must be adjusted.

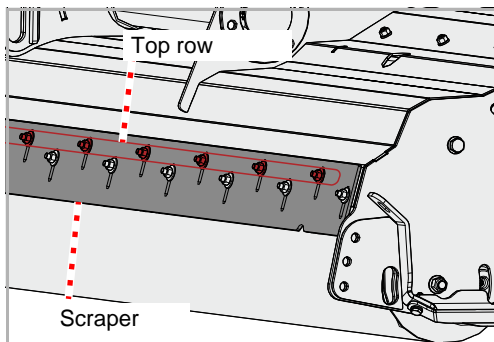

- ▶ Fit the scraper and secure with nuts and washers. Insert additional bolts in the top row and also secure with nuts and washers

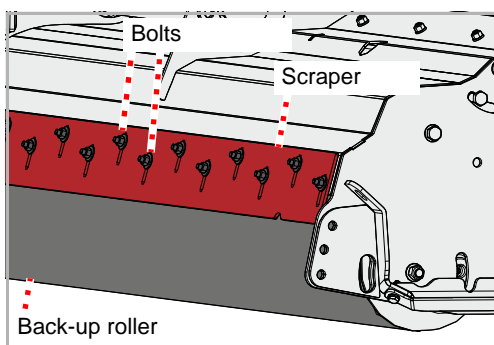

- ▶ Adjust the scraper so that the clearance between it and the support roller is 3-5 mm
- ▶ Check the clearance by turning the support roller. The support roller must not touch the scraper.
- ▶ Tighten the nuts

Preparation

Guide plate

The guide plate guides the mulched material in front of the support roller.

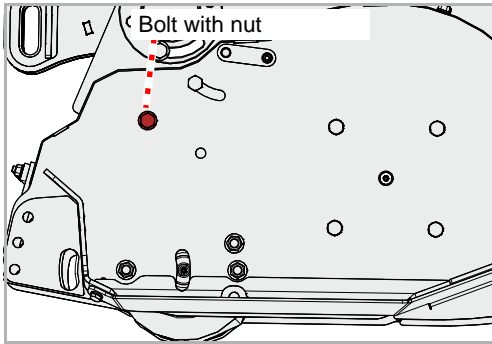

- ▶ Remove the nut and bolt
- ▶ Also remove the nut and bolt on the opposite side of the housing

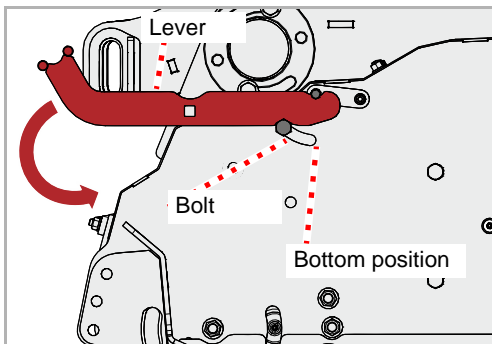

- ▶ Engage the lever and move the bolt into the bottom position
- ▶ Also engage the lever and move the bolt into the bottom position on the opposite side of the housing

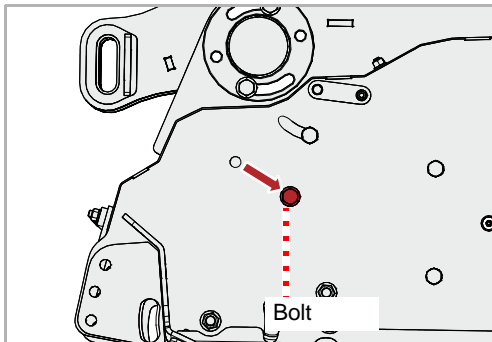

- ▶ Fit the nut and bolt and fix the guide plate in place
- ▶ Also fit the nut and bolt and fix the guide plate in place on the opposite side of the housing
- ▶ Move the lever back into park position

Behind the support roller

Depositing the cut material behind the support roller is the default setting. In this position, the support roller runs directly over the ground.



Store all parts together in a safe place. Should you wish to convert the support roller again at a later date, you will need the parts you removed again.

Scraper

You must remove the scraper.

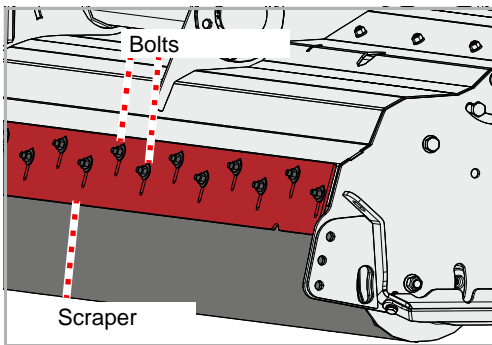

- ▶ Raise the machine slightly and secure it against lowering
- ▶ Undo the nuts and remove them along with the washers
- ▶ Remove the scraper

Back-up roller

The support roller must be swivelled into the front position.

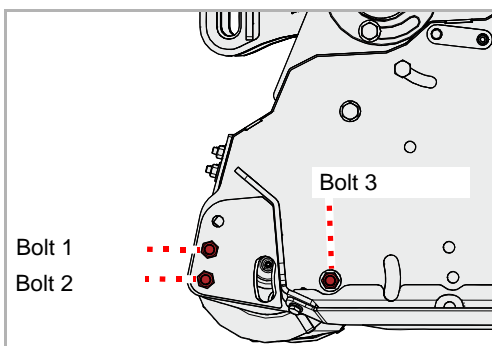

- ▶ Undo and remove bolts [1] and [2]
- ▶ Also undo and remove bolts [1] and [2] on the opposite side of the housing
- ▶ Loosen bolt [3] but do not remove it
- ▶ Also loosen, but do not remove, bolt [3] on the opposite side of the housing

The lever is located on the front-mounted flail mower

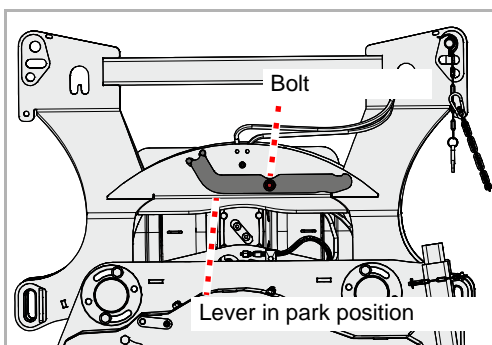

- ▶ Undo the bolt on the lever
- ▶ Move the lever out of park position

Preparation

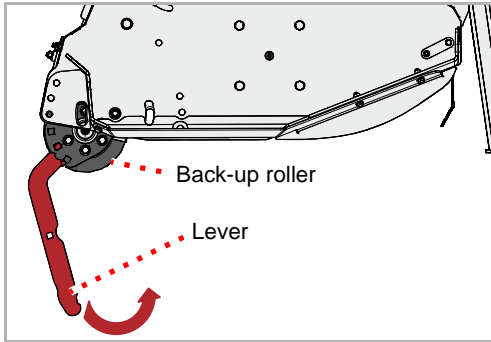

- ▶ Position the lever on the support roller

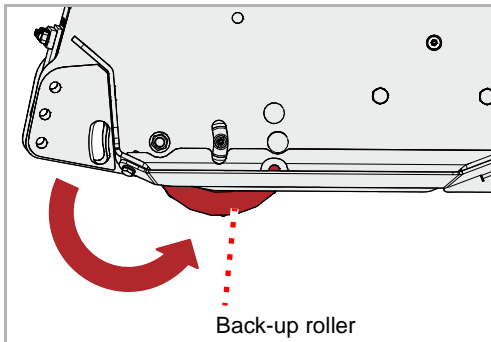

- ▶ Fold the support roller into the front position
 - ▶ Select the working depth
- Chapter »Preparation« paragraph »Working width«, page 46

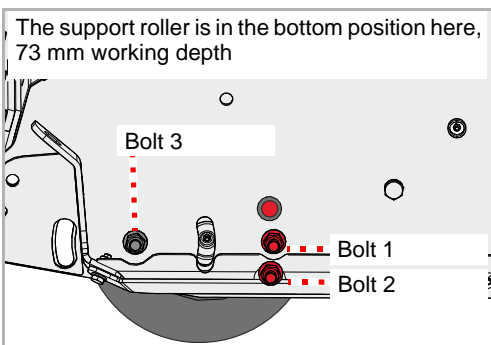

- ▶ Insert and tighten bolts [1] and [2]
- ▶ Retighten bolt [3]
- ▶ Make the same adjustment on the opposite side of the housing.

Rear stone guard

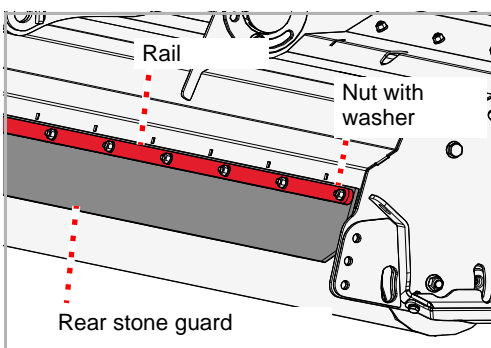

- ▶ Insert all bolts for the rail in the housing
- ▶ Attach rear stone guard and insert rail
- ▶ Fix the rail in place using nuts and washers

Guide plate

The guide plate must be configured so that the mulched material is guided behind the support roller.

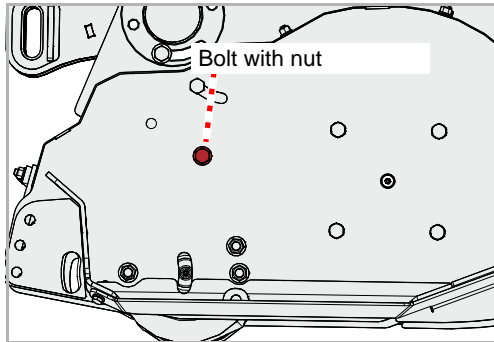

- ▶ Remove the nut and bolt
- ▶ Also remove the nut and bolt on the opposite side of the housing

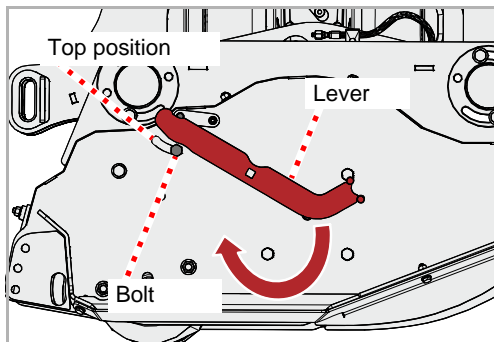

- ▶ Engage the lever and move the bolt into the top position
- ▶ Also engage the lever and move the bolt into the top position on the opposite side of the housing

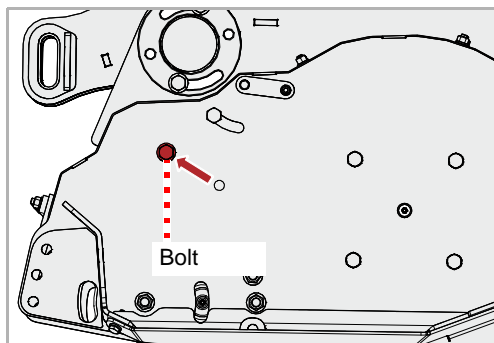

- ▶ Fit the nut and bolt and fix the guide plate in place
- ▶ Also fit the nut and bolt and fix the guide plate in place on the opposite side of the housing
- ▶ Move the lever back into park position

Additional guard [+]

For particularly sensitive application areas, you can fit an additional guard.

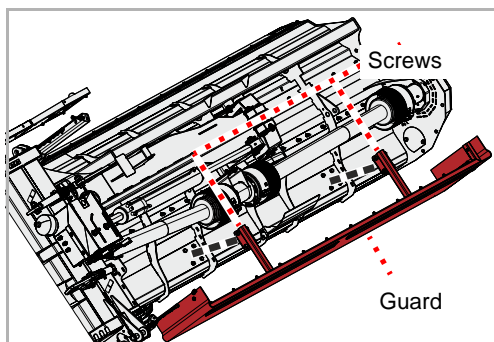

- ▶ Fit guard with 8 screws

Driving on the road

Transport position

Drawn variant

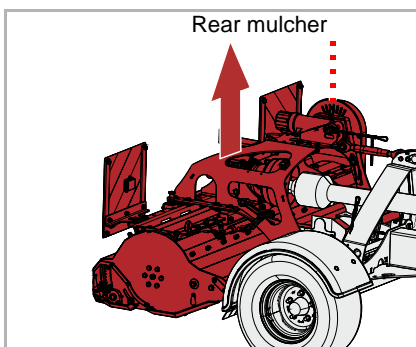
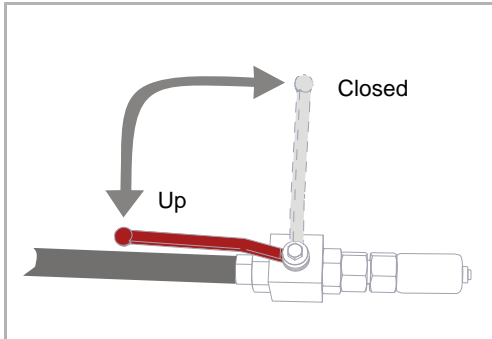

The rear mulcher is also tilted towards the front and lifted slightly.

- ▶ Lower the frame via the control valve of the tractor

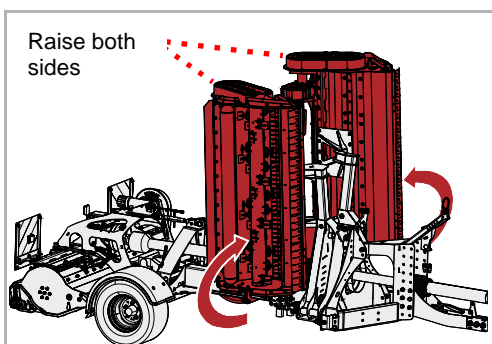

On tractors with braking device for PTO:

- ▶ Release brake of PTO on tractor

- ▶ Fold the machine in using the control valve of the tractor. Make sure that the two transport locking devices lock into place securely.
- ▶ Using the control valve of the tractor, adjust the drawbar so that the frame is horizontal
- ▶ Secure the control valves on the tractor against inadvertent operation

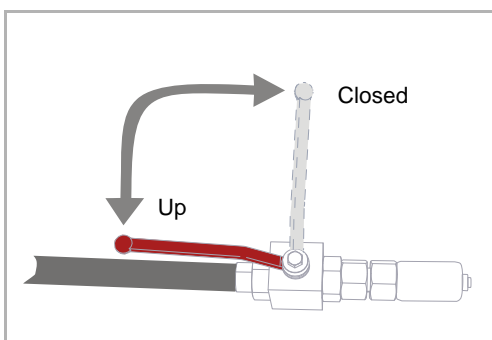

- ▶ Close the stop valve on the hydraulic connection for lifting the flail mower to the headland position and lowering it to the work position

Side shift

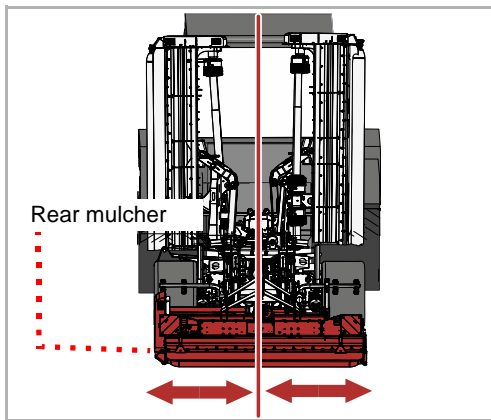

- ▶ Use the control unit to align the flail mower to centre rear. Make sure that the flail mower does not protrude sideways.

Separated variant

The folding-in procedure from the work position is described here.

If you fold in the machine from the headland position:

- ▶ Skip the following step

- ▶ Move the machine from the work position to the headland position via the control valve of the tractor
- ▶ Set the control valve for the transport locking devices on the tractor to the floating position. The transport locking devices must be in the "closed" position.

On tractors with braking device for PTO

- ▶ Release brake of PTO on tractor

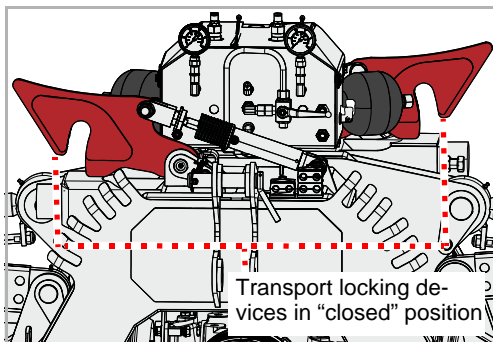

- ▶ Fold the machine in using the control valve of the tractor. The two transport locking devices lock automatically.
- ▶ Check whether the transport locking devices are securely locked

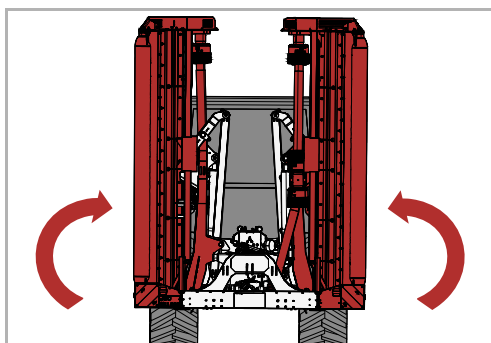

Driving on the road

Side protrusion of machine

Depending on the width of the tractor, the machine protrudes out to the side on the right and left-hand side. Adapt your driving style accordingly.

The overall width of tractor and machine must not exceed the maximum vehicle width permitted for road transport.

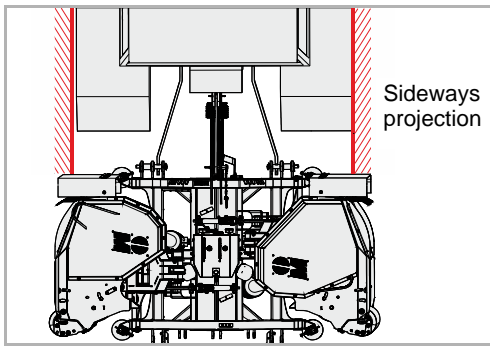

Lower link

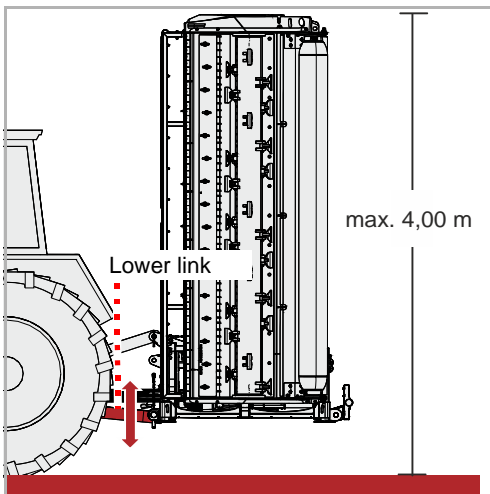

- ▶ Adjust the height of the lower links via the three-point linkage system of the tractor

Observe the following points when adjusting the height:

- The machine must have sufficient ground clearance for transport

Measured from the ground, the height of the machine should not exceed 4.00

Lighting equipment

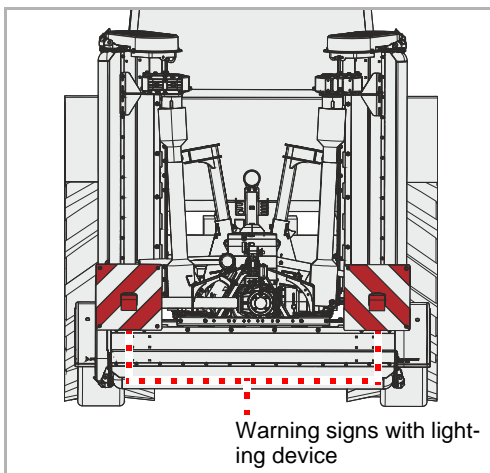

- ▶ Check lighting device for correct function

Control devices



Close the stop valves, secure the control devices

Prior to road transport, the control devices on the tractor must be secured against inadvertent actuation.

If the control devices on the tractor have not been secured, the machine may accidentally swing out into the work position during road transport. This can result in accidents.

Transport without coupling

For transport on, for example, a trailer, the machine can be raised. Only use the designated points for attaching the lifting device. The machine must be securely positioned.

- ▶ Setting down the machine in a secure position
- Chapter »Parking and storage« paragraph »Setting down the machine in a secure position«, page 71
- ▶ Attach suitable lifting gear to the load points
- ▶ Raise the machine with suitable lifting gear and position on the loading bed
- ▶ Secure the machine against slipping

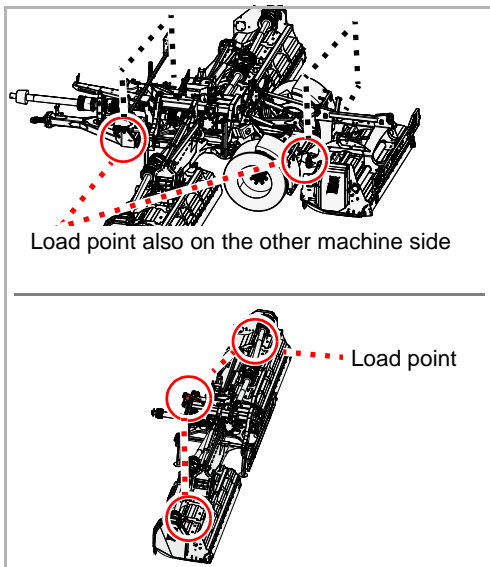

Mulching

Drawn variant

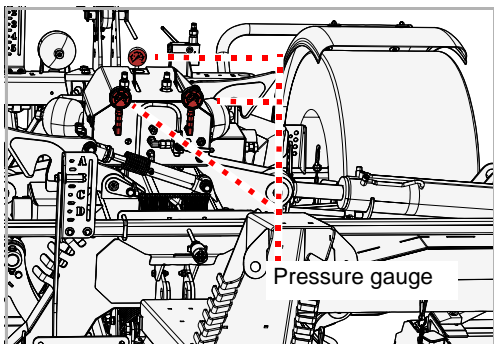

- ▶ Check the pressure at the pressure gauges:
The pressure should be between 50 and 55 bar.

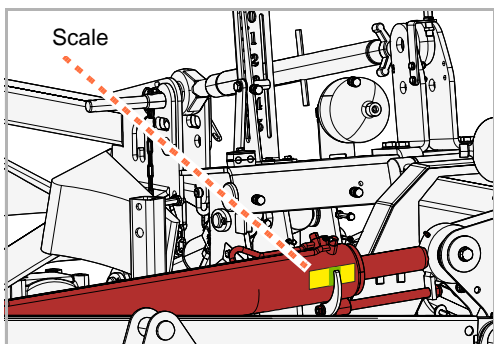

- ▶ Using the control units on the tractor, adjust the frame and the draw-bar as desired

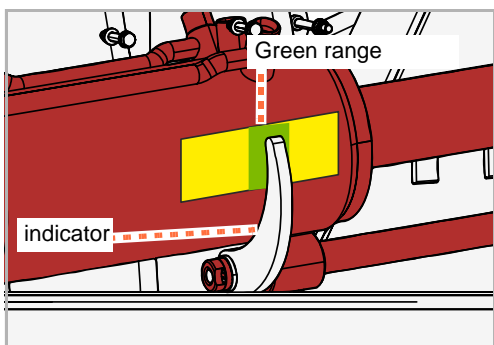

- ▶ Make sure that the indicator is in the green range of the scale

Rear mulcher

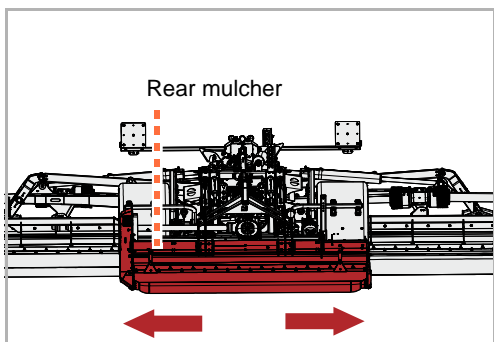

You can align the rear of the flail mower to the left or right as needed.

- ▶ Lift the flail mower to the headland position via the control unit on the tractor
- ▶ Using the control unit on the tractor, move the rear of the flail mower to the left or right as desired
- ▶ Using the control unit on the tractor, lower the flail mower to the work position

Separated variant

The machine works in two strips to the right and left of the tractor. The central strip is left unprocessed. The central strip is usually covered by an additional flail mower attached at the front.

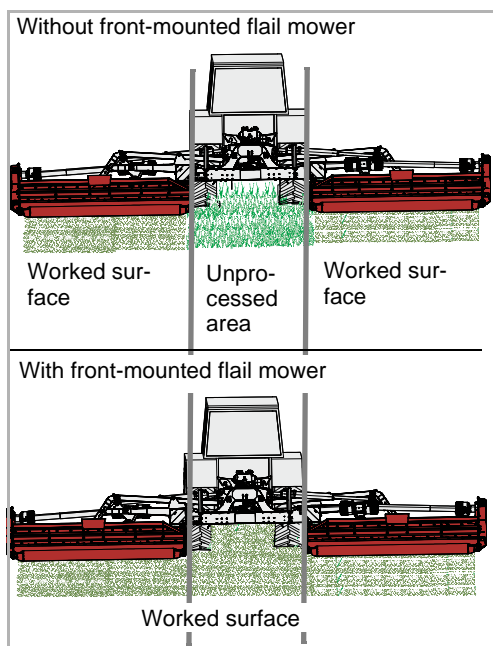

The flail mower for front attachment must be approved.
 → Chapter »About this operating manual« paragraph »Other applicable documents«, page 8

Folding out

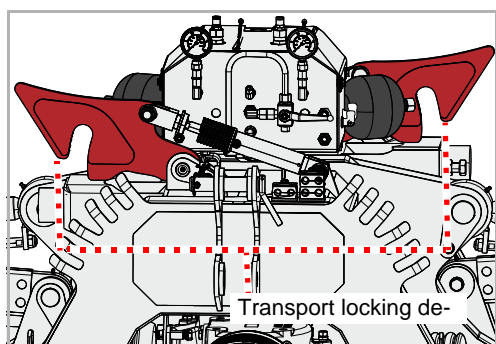

▶ Unlock the transport locking devices using the control unit on the tractor

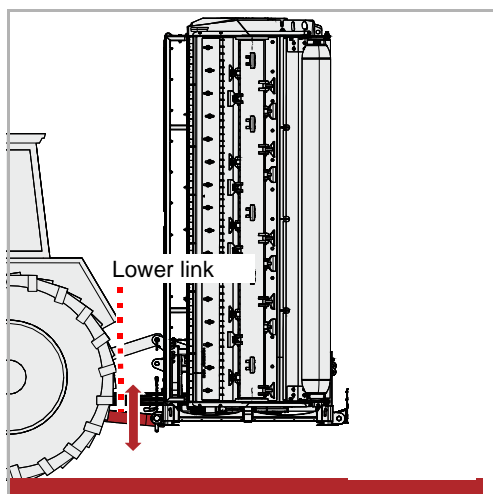

▶ Lower machine via lower link

Mulching

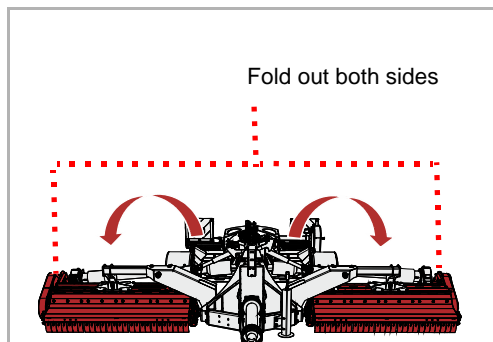

- ▶ Fold out both sides of the machine to the headland position using the control unit on the tractor

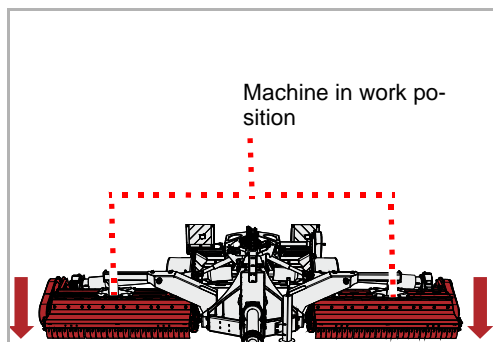

- ▶ Lower the machine to the work position using the control unit on the tractor. Wait until both sides of the machine are lowered to the same depth. The two flail mowers are now resting on the ground.
- ▶ Set the control valve on the tractor to „float position“

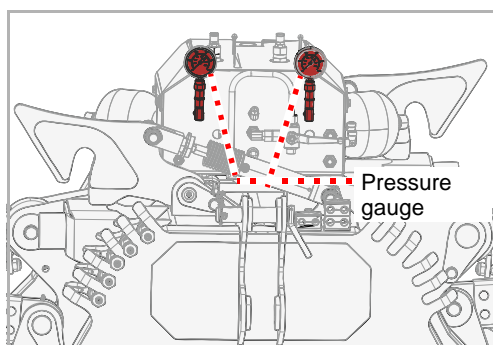

- ▶ Check the pressure at the pressure gauges:
The pressure should be between 50 and 55 bar.

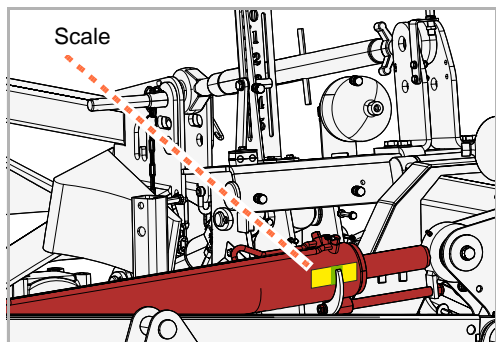

- ▶ Adjust the position as desired via the lower link and upper link on the tractor

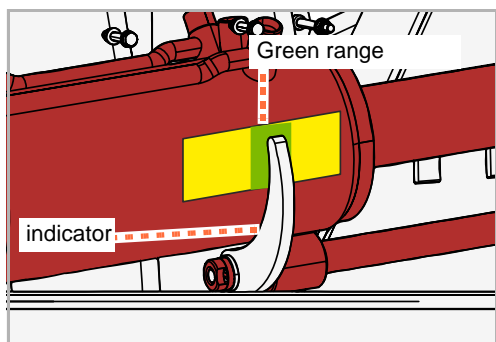

- ▶ Make sure that the indicator is in the green range of the scale

Mulching

Checking

You should check the following points before starting work:

- Are the side arms parallel to the ground?

Prerequisites for checking:

- The machine is in the work position
- The indicators on both hydraulic cylinders are in the green range

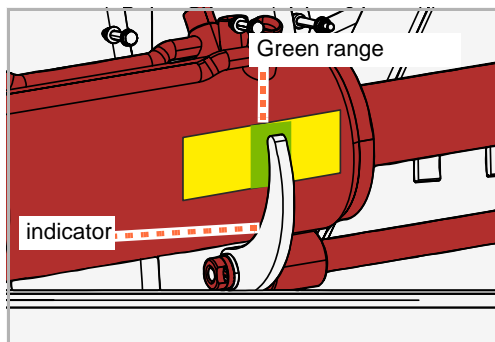

Side arms

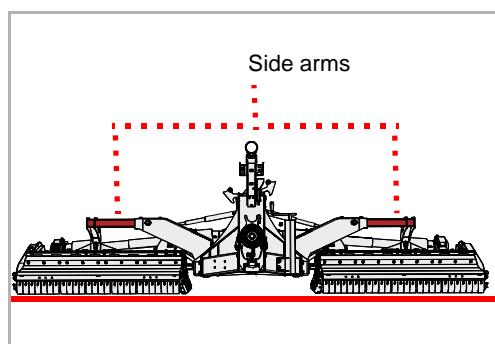

The side arms of the machine should be parallel to the ground.

If the arms are not parallel to the ground:

- ▶ Check pressure at pressure gauge and readjust pressure

Task

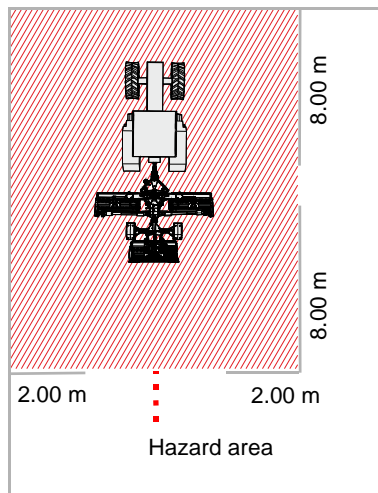

Check the hazard area

The hazard area in front of and behind the machine is 8 m, to the sides 2 m each. Before driving off, operating the machine and during operation, check its hazard area. Make sure that you have an adequate view. Do not begin work until the hazard area is cleared of any persons or objects.

Parts could be ejected from the machine at high speed in certain circumstances. The hazard area, particularly in front of and behind the machine, must be cleared of any persons, animals or objects before starting.

Any use of the machine without verification of the hazard area can lead to serious or fatal accidents.

Assess the dust exposure levels

If the ground and the material to be mulched are dry, you may be exposed to dust. Dust exposure can be avoided by taking into account the direction of the wind. If dust exposure cannot be avoided, you can protect yourself by wearing a dust mask. If these measures are not sufficient, use a tractor with an enclosed cab and a dust filter.

Dust exposure may lead to respiratory diseases.



Only work forwards

- ▶ The machine may only be located in work position when moving forwards. The machine must be raised up when reversing.

A machine in work position when reversing could result in serious damage to the machine.

Mulching

Particular care should be taken by the operator when working with the mulcher. Working on ditches, overhangs or slopes are activities which tend to be particularly hazardous. We can only give general instructions, the actual situation must be evaluated by the operator.

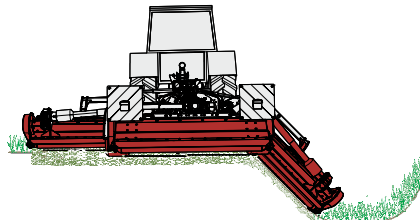
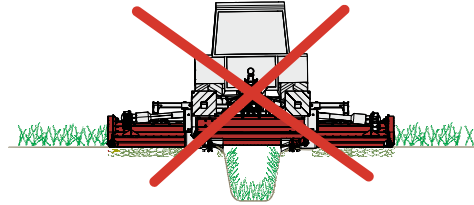
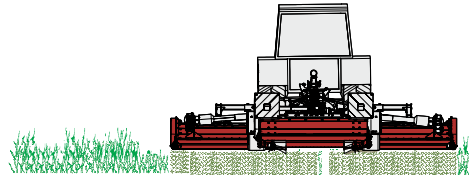

On ditches

Maximum permitted angle of inclination:

MU-Pro/F: -7°

MU-Pro/F Trail: -20°

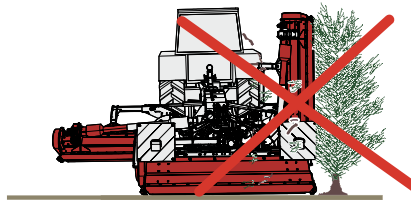

On slopes

Maximum permitted angle of inclination:

MU-Pro/F: $+10^{\circ}$

MU-Pro/F Trail: $+25^{\circ}$

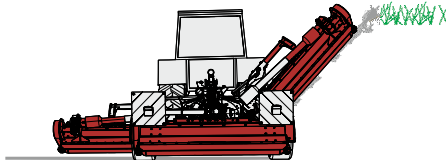

Switching on

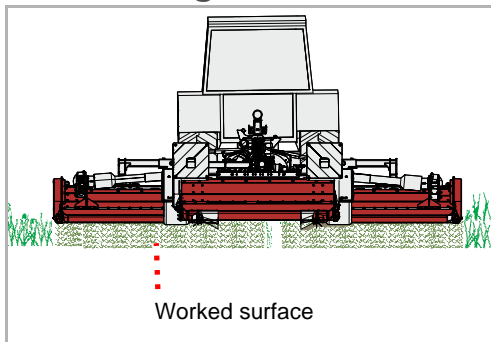

- ▶ Switch the PTO stub shaft into the work position and slowly bring the machine to the rated speed
- ▶ Then drive at low speed into the stock, increase speed slowly. Pay attention to the machine while doing this.

If the machine is working too hard:

- ▶ Reduce speed
- ▶ Drive at a suitable speed. The speed must be appropriate to the growth and the type of terrain.

Individual control

[+]

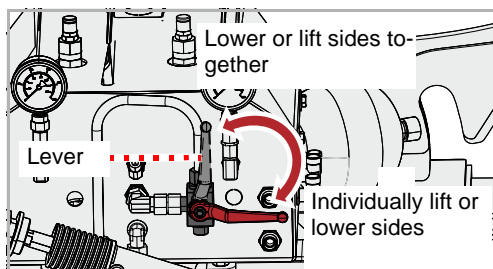

- ▶ Set the lever of the switching valve to the desired position

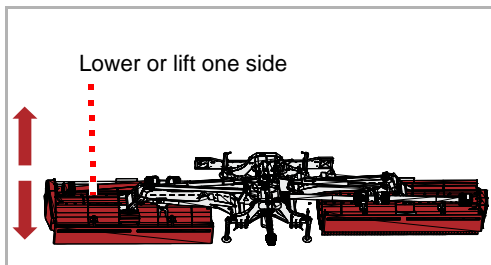

- ▶ Select the desired side via the control valve of the tractor and lift or lower the side

Cleaning and care

Cleaning

A high-pressure cleaner, for example, can be used to clean the machine. Never point the water jet directly at the labels or type plate.



Only use low pressure to clean the bearings

Only use low pressure to clean the bearings.

The ingress of water shortens the service life of the bearings.

Care

To ensure the machine's long service life, we recommend applying a protective coating of oil after the end of the season and during storage.



Use only approved and biodegradable oil, e.g. rapeseed oil.

Setting down the machine in a secure position



The machine can be parked in working position or in transport position.

Ensure that there are no unauthorised persons can enter the set-down location

If the machine is set down coupled or uncoupled on the tractor, the set-down location must be selected to ensure that no unauthorised persons can enter.

Persons could be injured by coming into contact with parts of the machine or by manipulating the machine.



Select the set-down location carefully

The set-down location must be relatively even and the ground must be solid.

Uneven or soft ground could result in the machine rolling away and becoming damaged.

Requirements on the set-down location:

- Horizontal, solid surface
- Sufficient room on all sides
- Protected against access by unauthorised persons, such as children

Drawn variant

You can set the machine down in the work position or in the transport position.

Work position

Prerequisites:

- The machine is mounted and connected to the tractor
- The machine is in the transport position
- The machine should be parked folded out in the work position

If the machine is already in the work position:

- ▶ Ignore the section »Folding out«

Parking and storage

Folding out

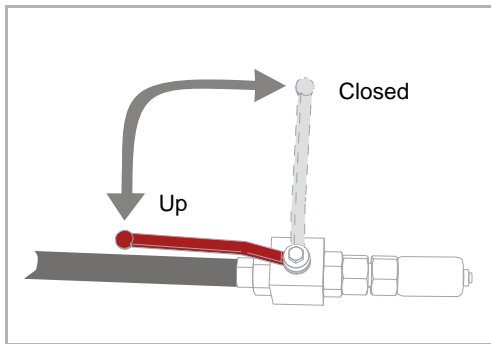

- ▶ Open stop valve at hydraulic connection number 1
- Chapter »Coupling the machine«, Section »Hydraulics« from page 41

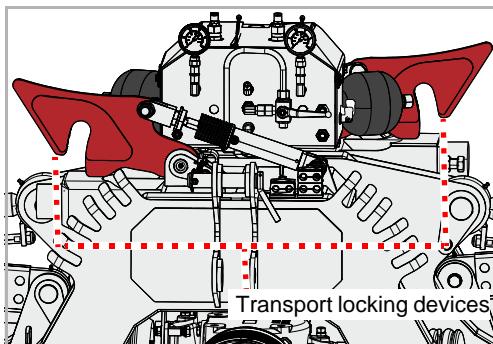

- ▶ Raise the frame via the control unit on the tractor. The transport locking devices are unlocked.
- ▶ Using the control unit on the tractor, adjust the drawbar so that the frame is horizontal

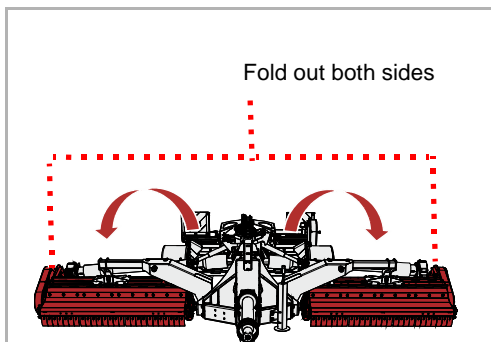

- ▶ Fold out both sides of the machine to the headland position using the control unit on the tractor

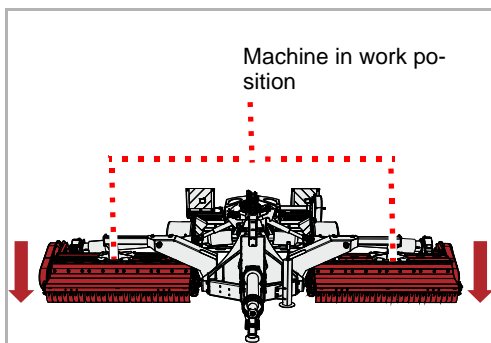

- ▶ Using the tractor's control device, lower the machine into the work position
- ▶ Raise the drawbar via the control valve on the tractor: Wait until both sides of the machine are lowered to the same depth.

Supporting legs

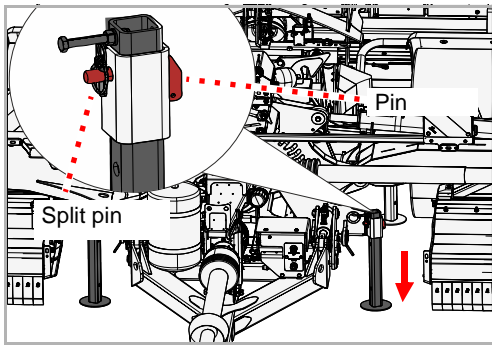

- ▶ Remove split pin at pin
- ▶ Pull out the pins
- ▶ Push both front supporting legs downwards and secure in lower position with pins and split pins
- ▶ Using the control unit on the tractor, adjust the drawbar so that there is no longer any tension on the coupling to the tractor

PTO shaft

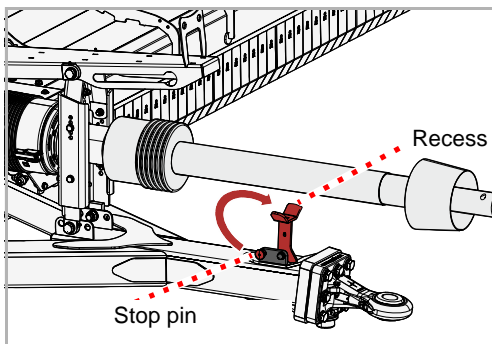

- ▶ Pull out locking bolt
- ▶ Fold up the holder, make sure that the locking bolt engages

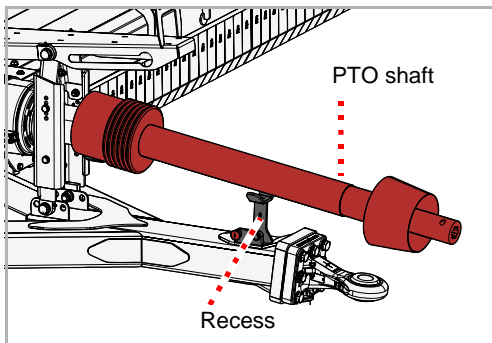

- ▶ Dismantle the PTO shaft on the tractor and place it in the holder

Parking and storage

Air pressure brake [+]

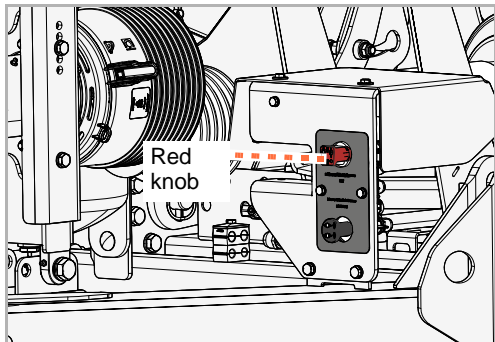

- ▶ Pull out red knob
- The wheels are now manually braked.

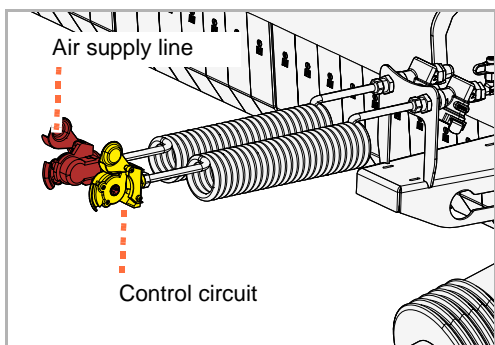

- ▶ Disconnect air supply line and control line on tractor
- ▶ Protect compressed air connections against debris with the protective cap and place in the holder

Hydraulics and electrics

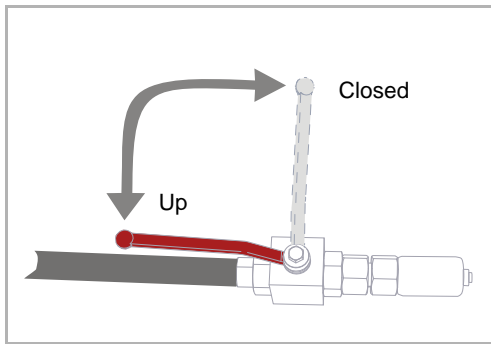

- ▶ Close stop valve at hydraulic connection number 1
- Chapter »Coupling the machine«, Section »Hydraulics« from page 41

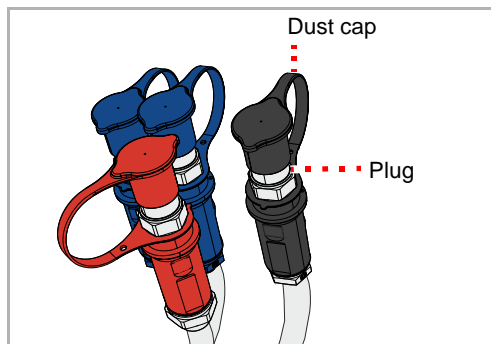

- ▶ Disconnect all hydraulic connections of the machine on the tractor
- ▶ Protect plugs with dust cap

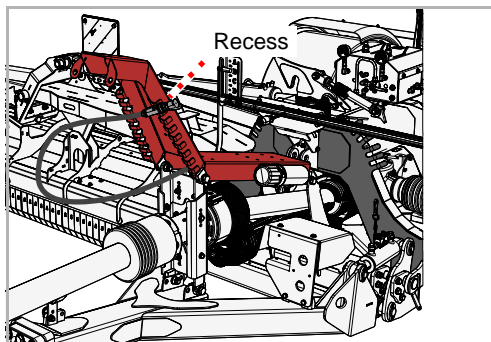

- ▶ Hook plugs onto stowage system
- ▶ Disconnect all electrical connections of the machine on the tractor
- ▶ Place electrical plug in holder

Wheel chocks

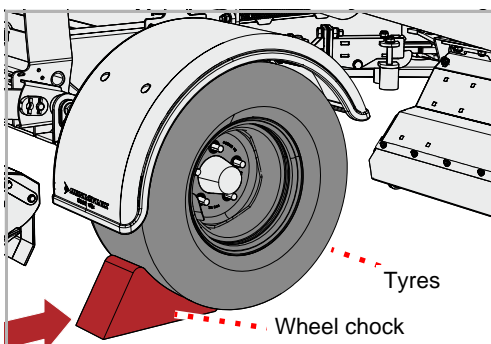

Secure the machine against rolling away using the wheel chocks.

- ▶ Remove the wheel chocks from the holder
- ▶ Push wheel chocks under the tyres on both sides of the machine

Drawbar

Depending on the coupling system, the steps required can vary. The general procedure for disconnection is described here

- ▶ Disconnect coupling on tractor
- ▶ Drive the tractor away from the machine slowly and carefully

Parking and storage

Transport position

Prerequisites:

- The machine is mounted and connected to the tractor
- The machine is in the work position
- The machine should be parked folded in, in the transport position

If the machine is already in the transport position:

- ▶ Ignore the section »Folding in«

Folding in

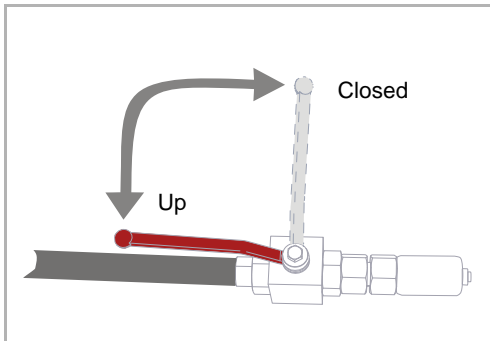

If the machine was parked and the stop valve was closed:

- ▶ Open stop valve at hydraulic connection number 1
→ Chapter »Coupling the machine«, Section »Hydraulics« from page 41

If you fold in the machine from the headland position:

- ▶ Skip the following step

- ▶ Move the machine from the work position to the headland position via the control valve of the tractor

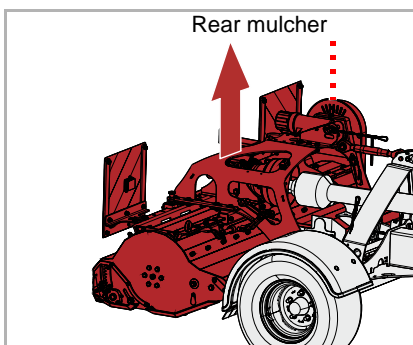

The rear mulcher is also tilted towards the front and lifted slightly.

- ▶ Lower the frame via the control valve of the tractor

On tractors with braking device for PTO

- ▶ Release brake of PTO on tractor

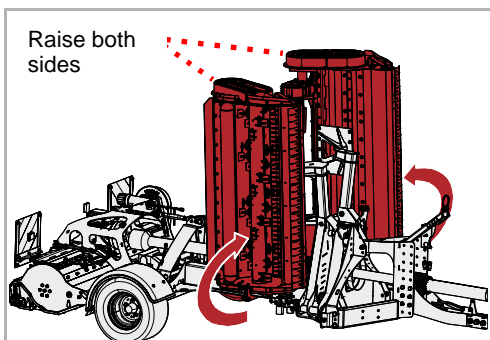

- ▶ Fold the machine in using the control valve of the tractor. Make sure that the two transport locking devices lock into place securely.
- ▶ Using the control valve of the tractor, adjust the drawbar so that the frame is horizontal

Supporting legs

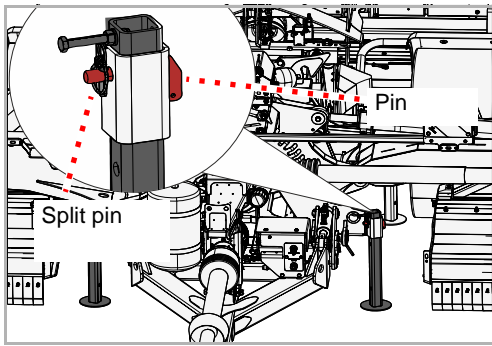

- ▶ Remove split pin at pin
- ▶ Pull out the pins

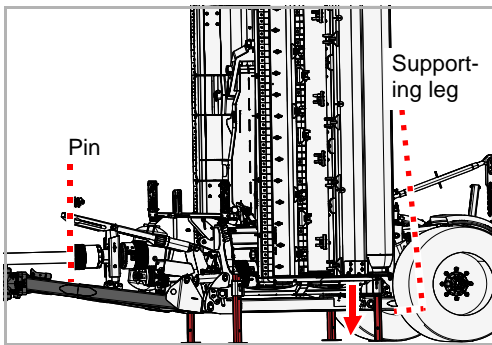

- ▶ Push all four supporting legs down and secure them in the lower position with pins and split pins
- ▶ Using the control unit on the tractor, adjust the drawbar so that there is no longer any tension on the coupling to the tractor

PTO shaft

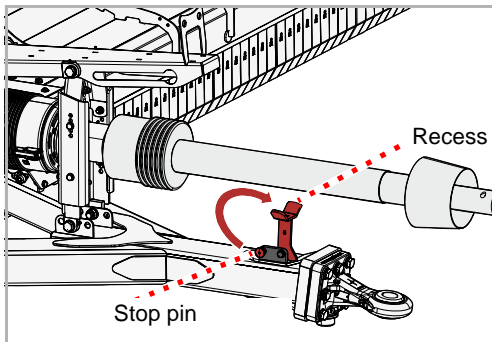

- ▶ Pull out locking bolt
- ▶ Fold up the holder, make sure that the locking bolt engages

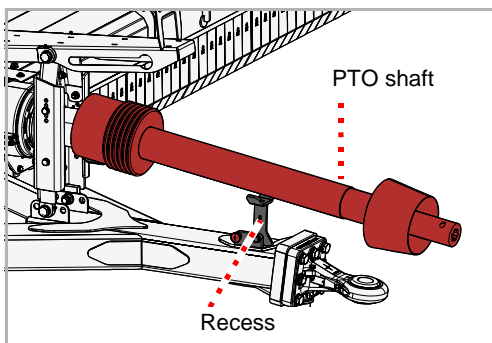

- ▶ Dismantle the PTO shaft on the tractor and place it in the holder

Parking and storage

Air pressure brake [+]

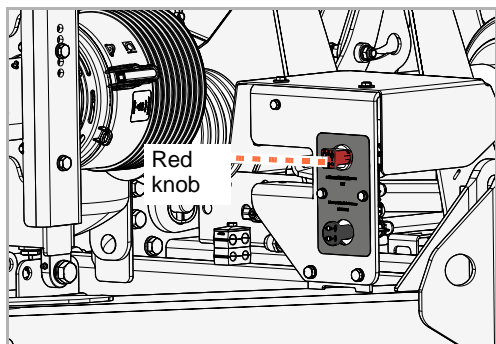

- ▶ Pull out red knob
- The wheels are now manually braked.

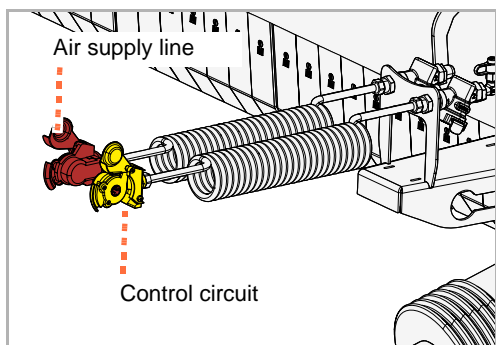

- ▶ Disconnect air supply line and control line on tractor
- ▶ Protect compressed air connections against debris with the protective cap and place in the holder

Hydraulics and electrics

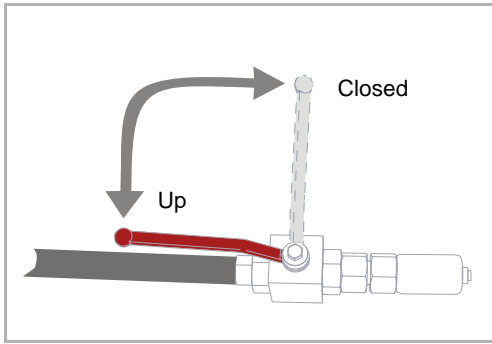

- ▶ Close stop valve at hydraulic connection number 1
- Chapter »Coupling the machine«, Section »Hydraulics« from page 41

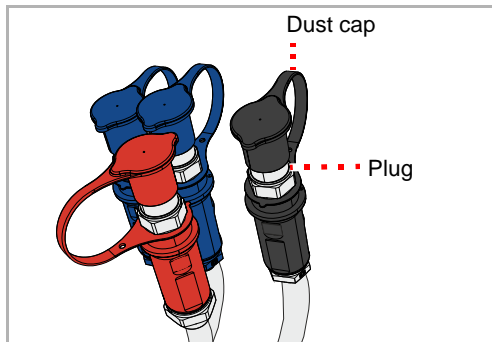

- ▶ Disconnect all hydraulic connections of the machine on the tractor
- ▶ Protect plugs with dust cap

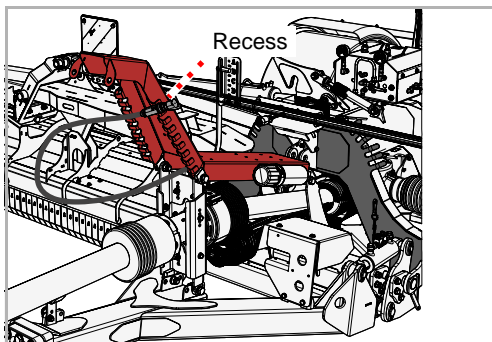

- ▶ Hook plugs onto stowage system
- ▶ Disconnect all electrical connections of the machine on the tractor
- ▶ Place electrical plug in holder

Wheel chocks

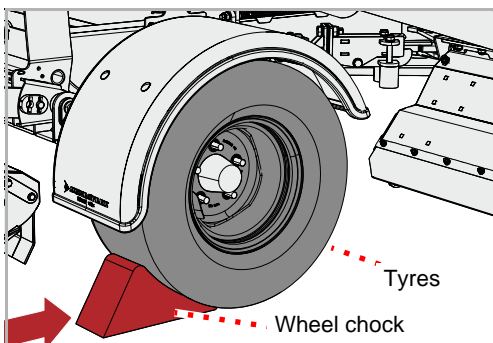

Secure the machine against rolling away using the wheel chocks.

- ▶ Remove the wheel chocks from the holder
- ▶ Push wheel chocks under the tyres on both sides of the machine

Drawbar

Depending on the coupling system, the steps required can vary. The general procedure for disconnection is described here

- ▶ Disconnect coupling on tractor
- ▶ Drive the tractor away from the machine slowly and carefully

Parking and storage

Separated variant

Work position

Prerequisites:

- The machine is mounted and connected to the tractor
- The machine is in the transport position
- The machine should be parked folded out in the work position

If the machine is already in the work position:

- ▶ Ignore the section »Folding out«

Folding out

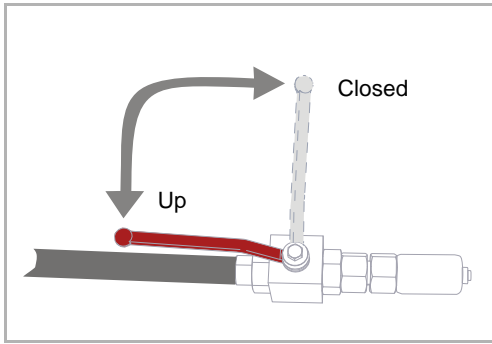

- ▶ Open stop valve at hydraulic connection number 1
- Chapter »Coupling the machine«, Section »Hydraulics« from page 41

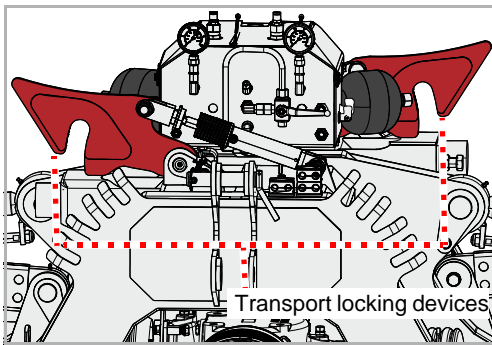

- ▶ Raise the frame via the control unit on the tractor. The transport locking devices are unlocked.
- ▶ Using the control unit on the tractor, adjust the drawbar so that the frame is horizontal

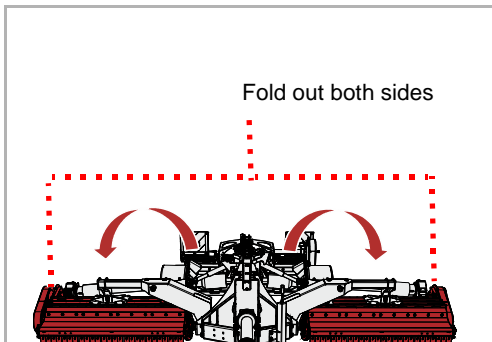

- ▶ Fold out both sides of the machine to the headland position using the control unit on the tractor

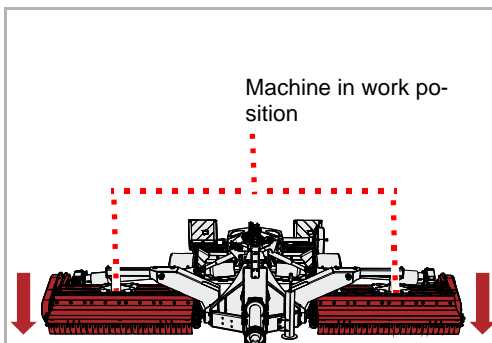

- ▶ Using the tractor's control device, lower the machine into the work position

Parking and storage

Supporting legs

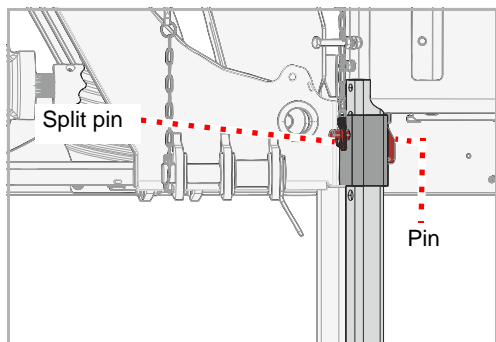

- ▶ Remove split pin at pin
- ▶ Pull out the pins
- ▶ Push supporting leg downwards and secure in bottom position with pin and split pin

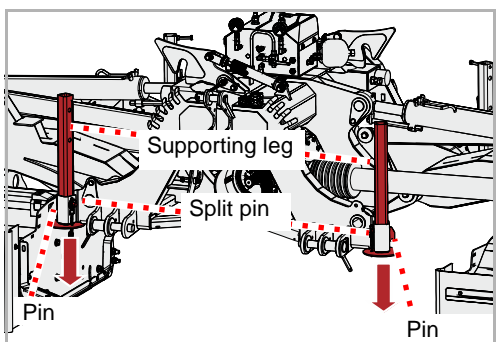

- ▶ Secure the remaining 3 supporting legs also in the lower position with pins and split pins

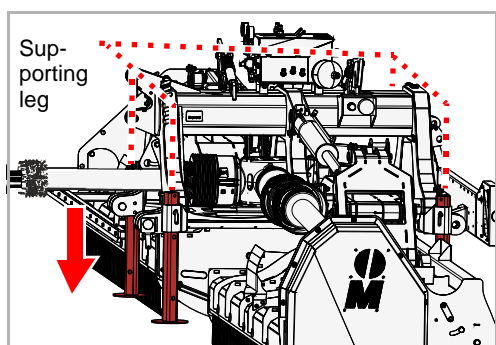

- ▶ Lower the lower link until the top link is no longer under compressive or tensile strain
- The machine is now standing on the supporting legs.

PTO shaft

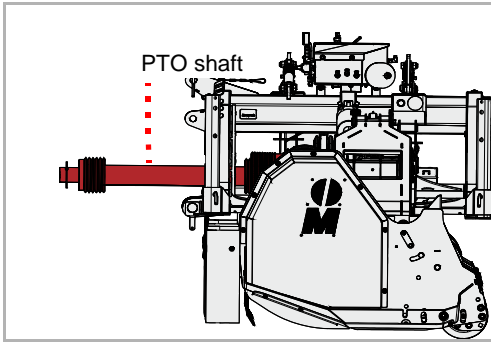

- ▶ Disconnect the PTO shaft from the tractor

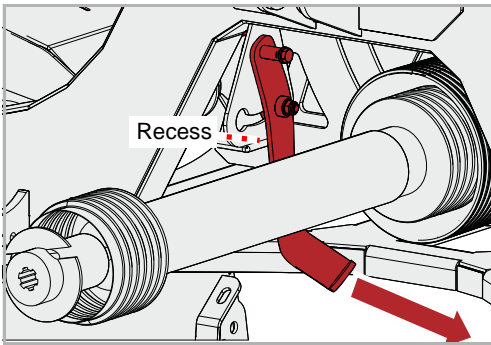

- ▶ Lift propeller shaft and pull storage system to the right

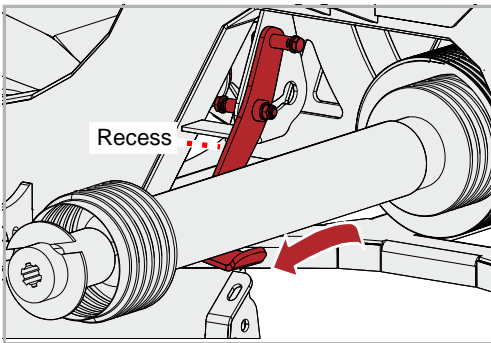

- ▶ Swivel the storage system to the front position and make sure that the storage system locks into place
- ▶ Place the PTO shaft to one side

Parking and storage

Transport position

Prerequisites:

- The machine is mounted and connected to the tractor
- The machine is in the work position
- The machine should be parked folded in, in the transport position

If the machine is already in the transport position:

- ▶ Ignore the section »Folding out«



Select the set-down location carefully

The set-down location must be relatively even and the ground must be solid.

People could be injured or killed by the machine tipping over on uneven or soft ground.



Pay attention to transport locking device

If the machine is set down without the transport locking device engaged, the side parts can drop down independently.

People could be crushed by parts of the machine dropping.

Folding in

The folding-in procedure from the work position is described here.

If you fold in the machine from the headland position:

- ▶ Skip the following step

- ▶ Move the machine from the work position to the headland position via the control valve of the tractor

- ▶ Set the control valve for the transport locking devices on the tractor to the floating position. The transport locking devices must be in the "closed" position.

On tractors with braking device for PTO

- ▶ Release brake of PTO on tractor

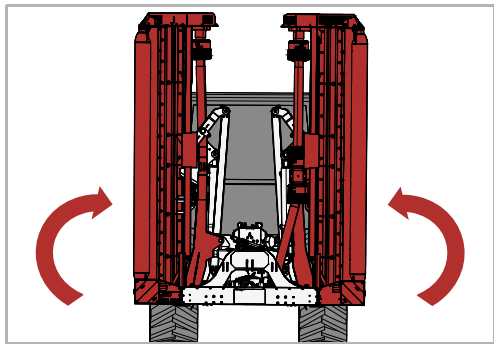
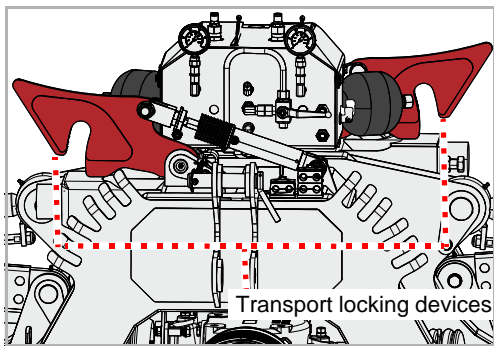

- ▶ Fold the machine in using the control valve of the tractor. The two transport locking devices lock automatically.

- ▶ Check whether the transport locking devices are securely locked

Parking and storage

Supporting legs

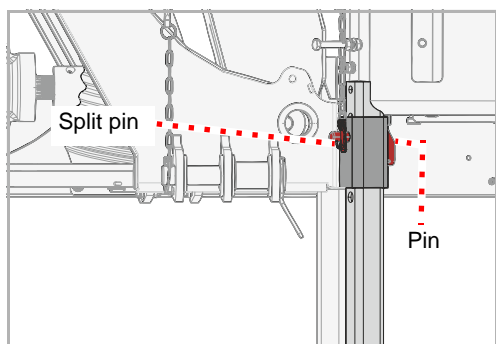

- ▶ Remove split pin at pin
- ▶ Pull out the pins
- ▶ Push supporting leg downwards and secure in bottom position with pin and split pin
- ▶ Also secure the remaining 3 supporting legs in the bottom position

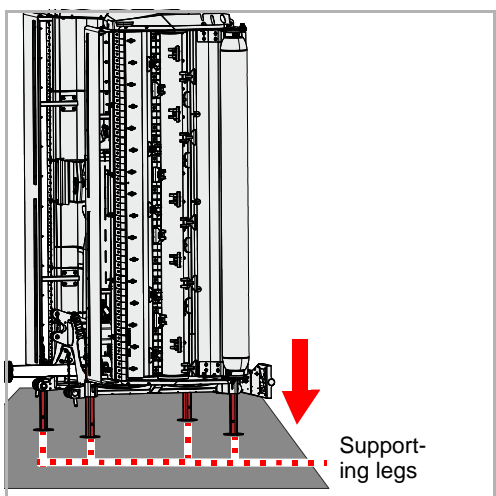

- ▶ Lower the lower link until the top link is no longer under compressive or tensile strain
- The machine is now standing on the supporting legs.

PTO shaft

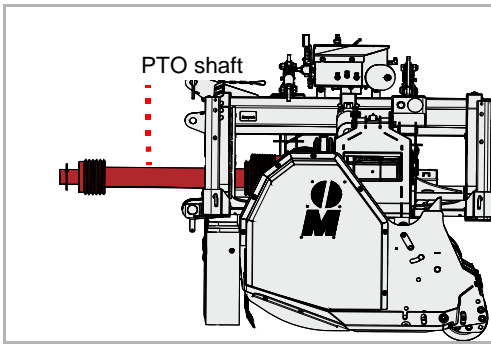

- ▶ Disconnect the PTO shaft from the tractor

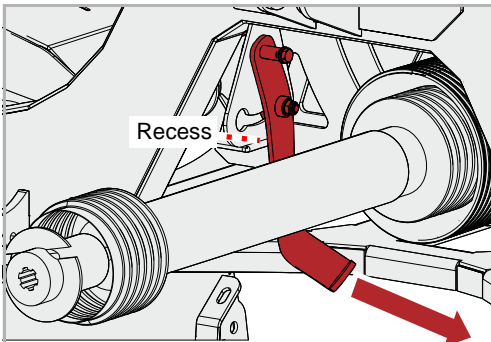

- ▶ Lift propeller shaft and pull storage system to the right

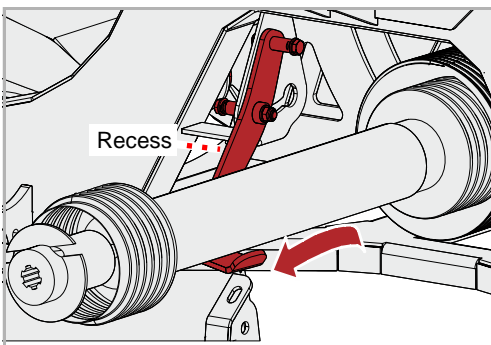

- ▶ Swivel the storage system to the front position and make sure that the storage system locks into place
- ▶ Place the PTO shaft to one side

Parking and storage

Hydraulics and electrics

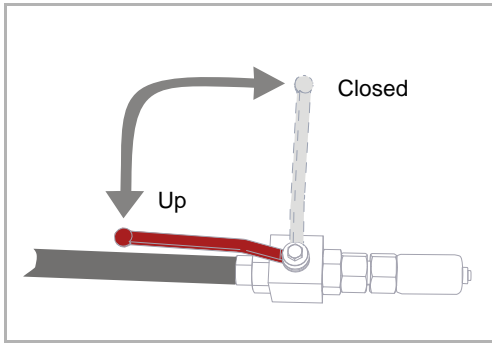

- ▶ Close stop valve at hydraulic connection number 1
- Chapter »Coupling the machine«, Section »Hydraulics« from page 41

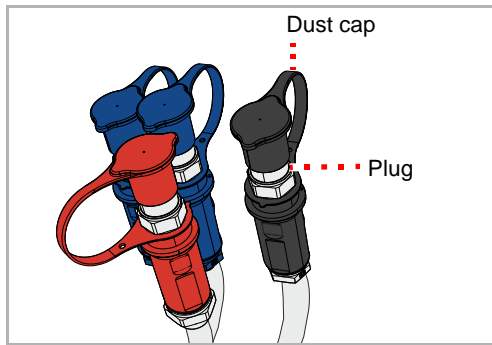

- ▶ Disconnect all hydraulic connections of the machine on the tractor
- ▶ Protect plugs with dust cap

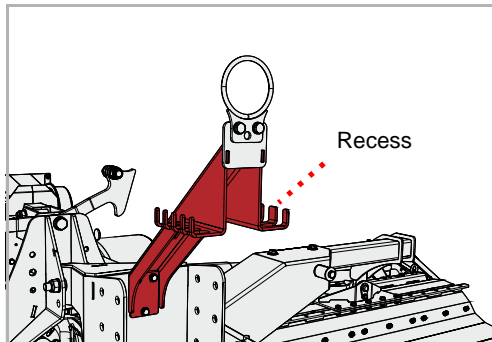

- ▶ Hook plugs onto storage system
- ▶ Disconnect all electrical connections of the machine on the tractor
- ▶ Place electrical plug in holder

Top link, lower link

- ▶ Remove the top link
- ▶ Undo the lower link and lower
- ▶ Drive the tractor away from the machine slowly and carefully

Storing the machine

After cleaning, the machine should be stored in transport position in a dry location and on a level and stable surface.

→ Section »Setting down the machine in a secure position«, Page 71



Apply a protective coating of oil during storage. Use only approved and biodegradable oil, e.g. rapeseed oil.

Chapter »Cleaning and care«, starting at page 70

For your safety

Special safety instructions



Requirements for conducting maintenance work

Only perform the maintenance work if you have the required expert knowledge and suitable tools.

A lack of specialist knowledge or the use of unsuitable tools can cause accidents.

Protect the machine from being started up accidentally

If the machine is coupled, only carry out repair and maintenance work and only rectify malfunctions on it if:

- The PTO stub shaft is off
- The engine is switched off
- The ignition key is removed

Serious accidents may be caused if the machine starts accidentally.



Welding work

Welding work may only be carried out by persons trained in welding who also have specialist knowledge of repairing agricultural machinery. Welding work which negatively impacts the machine's construction is prohibited.

Incorrect welding work could impair or destroy the machine's function. If in doubt, contact your dealer before carrying out any welding work.

Use original replacement parts

Many components have special properties that are essential for the stability and correct operation of the machine.

When replacing components, dimensions, stability and material quality must be guaranteed. We recommend the exclusive use of original replacement parts.

Use of replacement parts which do not correspond to requirements could cause damage to the machine or impaired performance.

Protective measures when handling oils or lubricants

Additives in oils and lubricants may have adverse effects on health. Since the hazardous material code does not require any special identification, please always observe the following:



Avoid skin contact

Avoid skin contact with these materials.
Contact can result in skin damage.

Protect your skin

When handling oils and lubricants, protect your skin with lotion or wear oil-resistant gloves.
Oils can be hazardous to your health.

Do not use oils for cleaning

Do not use oils or lubricants to clean your hands.
Swarf and abraded material in these materials can also result in injuries.

Change out of soiled clothing

Change out of clothing that is heavily soiled with oil as soon as possible.
Oils can be hazardous to your health.



- Collect old oil and dispose of it in accordance with statutory regulations.
- If your skin becomes irritated by oil or lubricants, contact a doctor immediately.

General information

This information relates to general maintenance work. For all maintenance work, the machine must be locked in the work position. If it is necessary to put the machine in its transport position for maintenance work, you will see an appropriate reference in the maintenance instructions.



Working with the grease gun:

One or two strokes with the grease gun are sufficient for lubrication. If you feel resistance during the second stroke of the grease gun, do not complete it.

Too much grease will force the bearings apart. This could allow dust and dirt to enter the bearing, resulting in premature wear.

The following table contains a brief explanation of the most important terms used for maintenance.

Task	Version
Greasing	<ul style="list-style-type: none"> • Apply grease to the slide surfaces using a brush
Lubrication	<ul style="list-style-type: none"> • 1 - 2 Unless specified otherwise, one or two strokes with the grease gun provide sufficient lubrication
Oiling	<ul style="list-style-type: none"> • Unless otherwise specified, use only vegetable-based oil such as rapeseed oil • Mineral oils are not suitable • The use of used oil will endanger your health and is also strictly prohibited
Replacement	<ul style="list-style-type: none"> • Replace the component in question according to the instructions in the »Maintenance« chapter
Check	<ul style="list-style-type: none"> • An inspection may be required in conjunction with the replacement of the component in question
Observe the maintenance intervals	<ul style="list-style-type: none"> • All information is based on average machine usage • In the case of heavy usage (e.g. contract work), shorten the maintenance intervals accordingly • Shorter maintenance intervals may also be required under extreme working conditions (e.g. heavy dust generation)

Screwed connections

Retighten screws

All bolts must be retightened:

- After the first hours of operation
- According to the frequency of use
- But at least once a season

General tightening torques

Tighten all screwed connections in accordance with the information in the table. If different tightening torques are necessary, they are specified in the chapter »Maintenance«. The minimum quality of the bolts is 8.8.

Bolt size	Quality of the bolts		
	„8.8“	„10.9“	„12.9“
	Tightening torques in Nm		
M6	9.9	14	17
M8	24	34	41
M10	48	68	81
M12	85	120	145
M16	210	290	350
M20	425	610	710
M24	730	1050	1220

Maintenance

Maintenance intervals and setting work

The information relates to average usage under the machine's normal operating conditions. Maintenance intervals are shorter for heavy usage, such as with hire companies, or for extreme operating conditions such as very dusty environments.

	After the first hours of operation	Once daily	After 30 hours of operation	After 60 operating hours	After 75 hours of operation	After 100 operating hours	After 250 operating hours	Once per season	As required	In case of wear	grease / oil / lubricate	Check	Replacement	Cleaning
General														
Retighten all screws	•								•					
Visual inspection	•	•												
Bearing		•							•		•			
Pivots		•										•		
Drawn variant: Tyres		•										•		
Hydraulics														
Hydraulic hoses Every 6 years													•	
Hydraulic hoses General									•	•			•	
Hydraulic cylinder		•		•	•	•			•		•	•		
air pressure brake														
brake hoses Every 6 years													•	
brake hoses General		•							•	•			•	
Drain compressed-air reservoir				•					•					
Readjust brakes								•	•					
Tools														
Fastenings on the rotor		•										•		
Condition, wear		•										•		•

	After the first hours of operation	Once daily	After 30 hours of operation	After 60 operating hours	After 75 hours of operation	After 100 operating hours	After 250 operating hours	Once per season	As required	In case of wear	grease / oil / lubricate	Check	Replacement	Cleaning
Other														
Position of rotor		•									•			
Roller bearing		•									•			
PTO shaft to tractor				•							•			
PTO shafts on machine						•					•			
Protective covers of PTO shafts		•										•		
Transmission oil		•						•				•		•

Lubricating work

Lubricate bearings

The bearings must be lubricated regularly. Lubricate only with one or two strokes from the grease gun:

- According to the maintenance chart
- After heavy use
- But at least once a season

Bearings that require no maintenance must not be lubricated.

Other lubrication points

The following applies:

- In addition to the lubrication points shown in this operating manual, your machine may have other lubrication points
- As a rule, lubrication points are located at pivots or bearings. Therefore, inspect your entire machine for any such additional lubrication points.



The location of the lubricating nipple is usually shown on one component as an example. If multiple components of this kind exist, the lubricating nipples have to be lubricated at each of these components.

Overview of lubrication points

Drawn variant

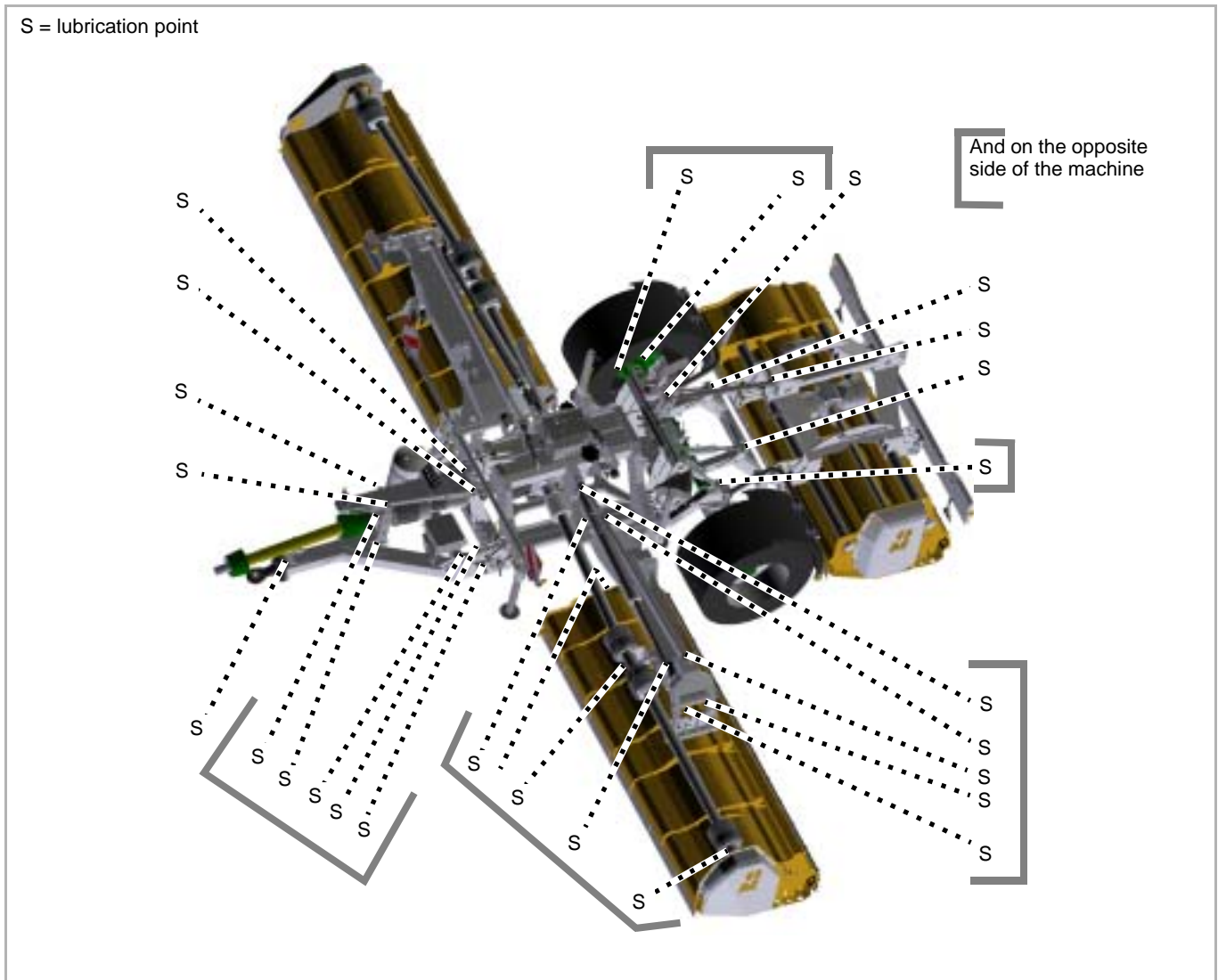

Rear mulcher

→ Operating manual of mulcher

Maintenance

Separated variant

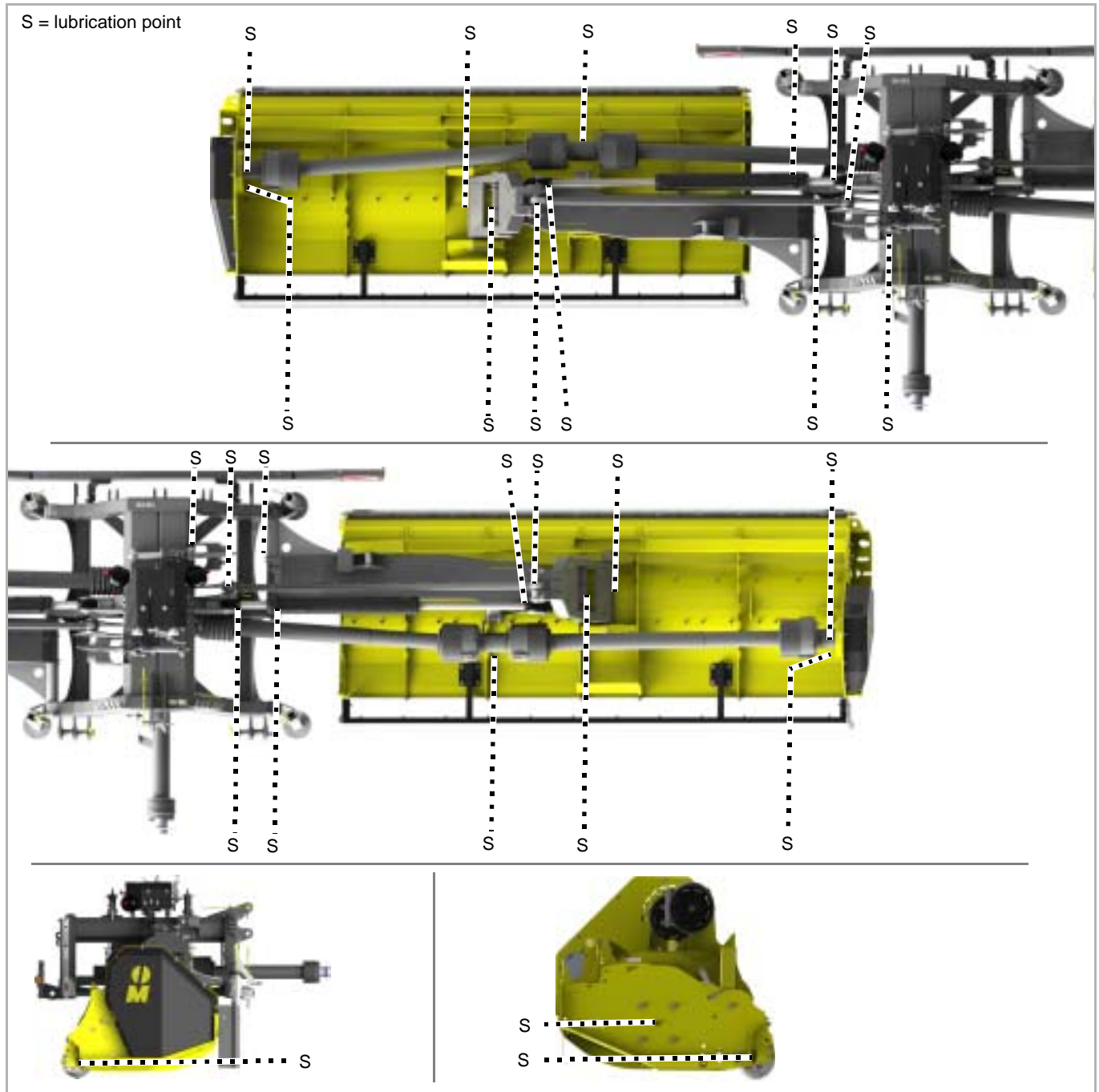

Front-attached flail
mower

→ Operating manual of mulcher

PTO shaft

The PTO shafts are heavily stressed. This means that regular maintenance is decisive for the PTO shafts' service life. Only the most important work is shown here.

Full maintenance work on the PTO shaft:

→ PTO shaft operating manual

Checking

Daily

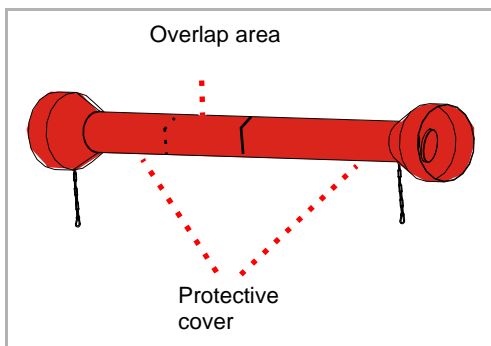

- ▶ Check the PTO shaft for contamination and clean if required. Dust in conjunction with oil and grease results in increased wear

If the PTO shaft is heavily contaminated:

- ▶ Clean PTO shaft
 - ▶ Grease the interior of the overlap area of the protective cover
- PTO shaft operating manual

- ▶ Check protective cover for damage

If the protective cover is damaged:

- ▶ Replace protective cover
- PTO shaft operating manual

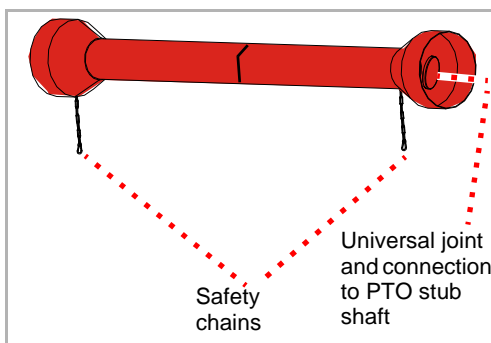

- ▶ Check presence and correct function of safety chains

If the safety chains are not present or are heavily worn:

- ▶ Replace the safety chains
- PTO shaft operating manual

- ▶ Check the PTO shaft for wear in the universal joints and at the connection to the PTO stub shaft

If the universal joints are heavily worn:

- ▶ Replace the universal joints
- PTO shaft operating manual

Lubrication

See operating manual for propeller shaft

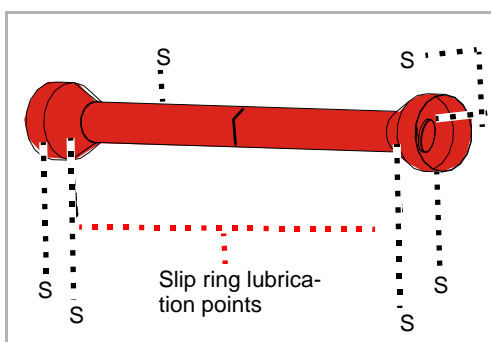

- ▶ Lubricate in the universal joint with 1 - 2 strokes of the grease gun.
- ▶ Lubricate on the slip rings with 1 - 2 pumps of the grease gun

Secure the machine

Before maintenance work, repair work or inspection work on the machine, you must secure the machine to protect against accidental lowering, tipping over or falling of machine parts.

This section describes how to secure the machine when the tractor is hitched. If you wish to uncouple the machine, you must also observe the information on parking and uncoupling.

→ Chapter »Parking and storage« from page 71



Select the set-down location carefully

The set-down location must be relatively even and the ground must be solid.

If the ground slopes or gives way, the machine can slip away and persons can be injured or killed.

Depending on the work you want to do, it may be beneficial to change the position of the machine. Which of the options you choose depends on the task you want to perform.

This requires a qualified decision. Persons who can make a qualified decision meet the following requirements:

- They have experience in handling agricultural machinery
- They can perform repairs on such machines independently and on their own responsibility
- They can assess hazards and take appropriate measures to secure machines

If you cannot make a qualified decision:

- ▶ Commission an appropriate specialist workshop to carry out the work

Drawn variant

The machine can be safely parked in the following positions:

- In work position
- In headland position
- In transport position

Not all work can be performed in the respective position. You should therefore choose the best position for the work you want to do.

Work position



The following operations are not possible in the work position:

- Adjustment work on the flail mowers
- Work on the underside of the flail mowers

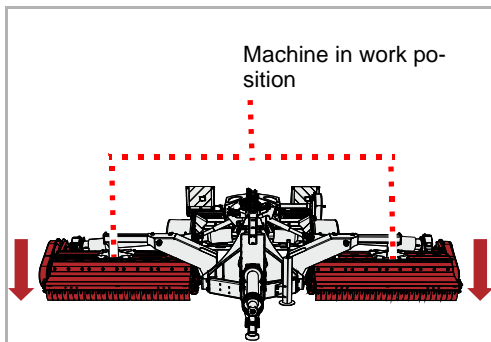

▶ Park machine in work position

→ Chapter »Mulching« paragraph »Work position«, page 71

▶ Secure the tractor and machine against rolling away and accidental startup

Headland position



The following work is not possible in the headland position:

- Most of the work on the underside of the flail mowers

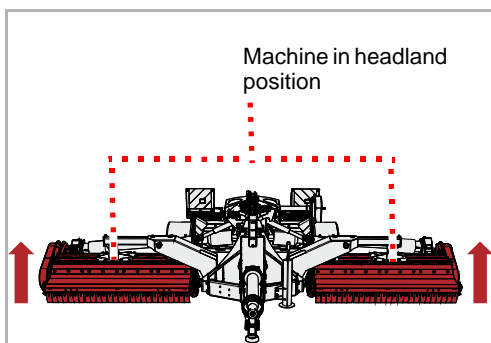

▶ Move the machine from the work position to the headland position

→ Chapter »Mulching« paragraph »Work position«, page 71

▶ Secure the tractor and machine against rolling away and accidental startup

▶ Secure flail mower against sinking down with suitable supporting legs

Maintenance

Transport position



The following work is not possible in the transport position:

- Adjustment work on the flail mowers
- Most of the work on the frame and the top of the flail mowers

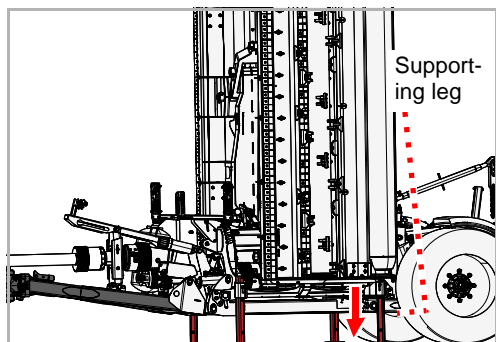

- ▶ Put machine in transport position
→ Chapter »Mulching« paragraph »Transport position«, page 76
- ▶ Secure the tractor and machine against rolling away and accidental startup
- ▶ Park the machine on the supporting legs

Separated variant

The machine can be safely parked in the following positions:

- In work position
- In headland position
- In transport position

Not all work can be performed in the respective position. You should therefore choose the best position for the work you want to do.

Work position



The following operations are not possible in the work position:

- Adjustment work on the flail mowers
- Work on the underside of the flail mowers

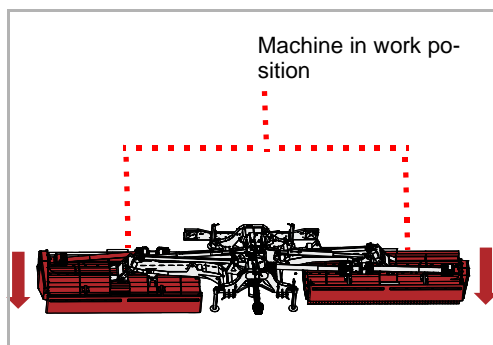

- ▶ Park machine in work position

→ Chapter »Mulching« paragraph »Work position«, page 71

- ▶ Secure the tractor and machine against rolling away and accidental startup

Headland position



The following work is not possible in the headland position:

- Most of the work on the underside of the flail mowers

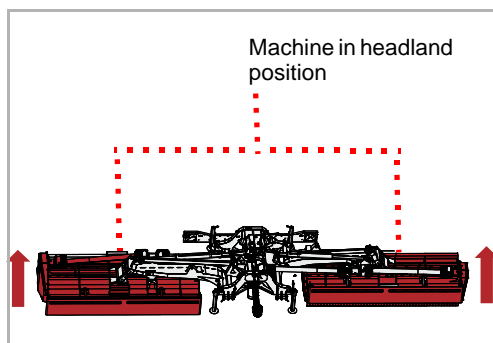

- ▶ Move the machine from the work position to the headland position

→ Chapter »Mulching« paragraph »Work position«, page 71

- ▶ Secure the tractor and machine against rolling away and accidental startup
- ▶ Secure flail mower against sinking down with suitable supporting legs

Maintenance

Transport position



The following work is not possible in the transport position:

- Adjustment work on the flail mowers
- Most of the work on the frame and the top of the flail mowers

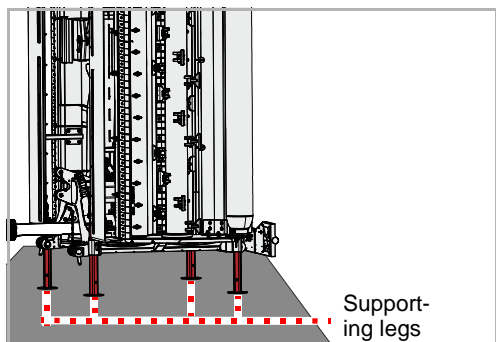

- ▶ Put machine in transport position
→ Chapter »Mulching« paragraph »Transport position«, page 76
- ▶ Park the machine on the supporting legs
- ▶ Secure tractor against rolling away and accidental startup

Transmission oil

The gearbox oil must conform to the specification.
→ Chapter »Familiarising yourself with the machine« paragraph
»Technical specifications«, page 27

Gear-box

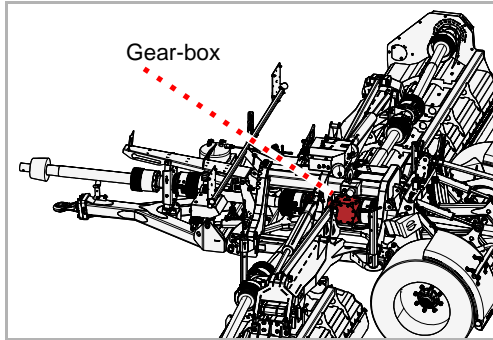

The twin gear box is located under the hydraulic centre.

Check

Twice per season

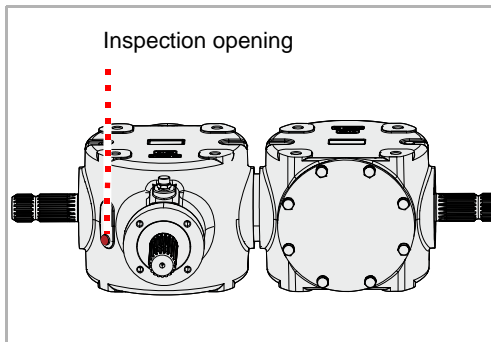

The twin gear box is located under the hydraulic centre. Since this is a twin gear box, you must also perform all work on the other side of the gear box.

- ▶ Loosen the screw on the inspection opening with an Allen key and remove the screw
- ▶ Check the oil level. The oil level must reach the lower edge of the inspection opening.
- ▶ Retighten the screw at the inspection opening

Maintenance

Refilling

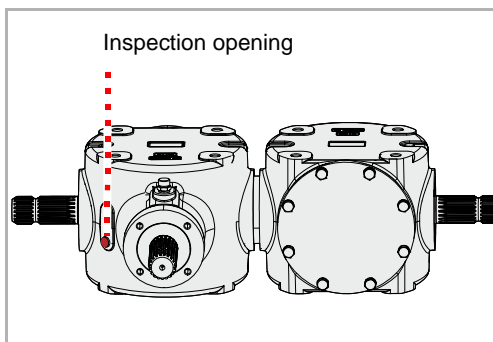

- ▶ Loosen the screw on the inspection opening with an Allen key and remove the screw

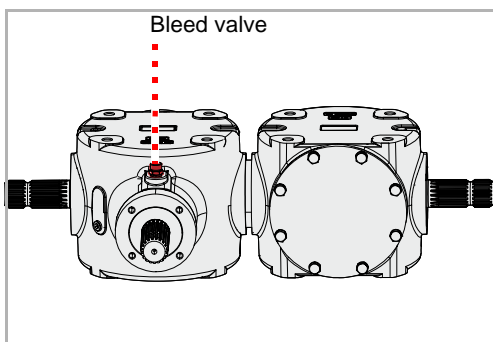

- ▶ Unscrew the bleed valve
- ▶ Use a funnel to fill with gear oil of the appropriate specification until the oil level reaches the lower edge of the inspection opening
- ▶ Retighten the screw at the inspection opening
- ▶ Screw the bleed valve back in

Replacement

1x per season

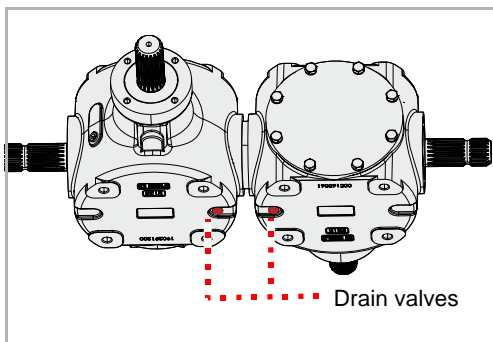

- ▶ Have a collection container ready for the waste oil
 - ▶ Open drain valve
 - ▶ Allow the oil to drain out fully
 - ▶ Close drain valve
 - ▶ Refill with new gear oil
- Section »Refilling«

air pressure brake system

Readjust brake

Every 2 years or as needed

Operations:

- Readjust brake
- Drain brake

Have the free stroke of the brake piston checked and, if necessary, adjusted at a specialist workshop:

- When the braking effect decreases
- Or at least every 2 years

Drain brake

Once per season or after heavy use

After heavy use of the brake system, it is necessary to drain the compressed-air reservoir of the brake.

- ▶ Secure the machine

→ Chapter »Maintenance«, Section »Secure the machine«, Page 100

- ▶ Pull the ring under the compressed-air reservoir forwards. Air and water escape.
- ▶ Release ring. The compressed-air reservoir is sealed again.

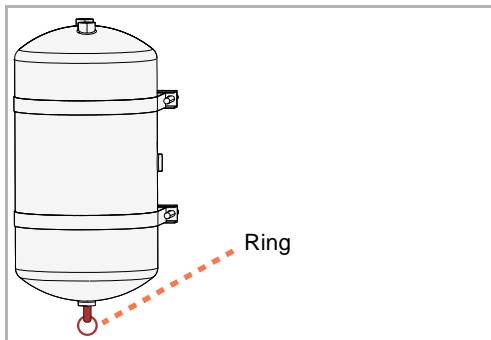

Maintenance

Tools

As required

The tools must be replaced if they:

- Are damaged
- Are heavily worn
- The bore on the tool is worn
- The fastening screws or the fastening nuts are worn

It is important that the rotor runs without unbalance. Therefore:

- Always replace tools with the same type
- Always replace tools opposite each other at the same time
- In case of wear it is best to replace the entire set of tools



Secure the machine

Work can only be carried out on a machine secured against rolling away and dropping. To prevent dropping, for example, permitted and correctly dimensioned support legs can be used.

If the machine is not secured against rolling away and dropping, serious or fatal accidents could result.



New tools – new nuts and bolts

When replacing the tools, the nuts and bolts must also be replaced. *If the nuts and bolts are not replaced, the worn bolts may break. Tools may become detached during work and be flung out. Even persons outside of the hazard area could be seriously injured or killed.*



Use original replacement parts

The nuts and bolts for fastening tools have special properties and strengths.

If the nuts and bolts do not have the required properties, tools may become detached during work and be flung out. Even persons outside of the hazard area could be seriously injured or killed.

Hammer flail

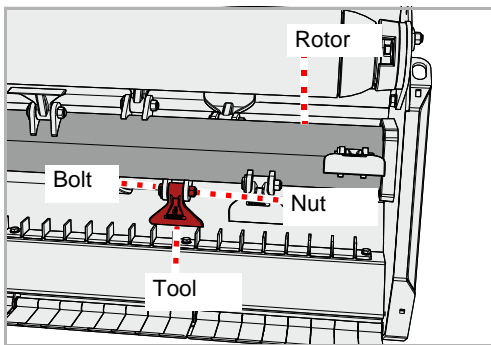

- ▶ Secure the machine against rolling away and dropping
- ▶ Loosen the nuts and remove the bolts
- ▶ Remove old tool
- ▶ Insert the new tool in the same way.
- ▶ Fit a new screw and secure with a new nut

V-belt

As required

Checking

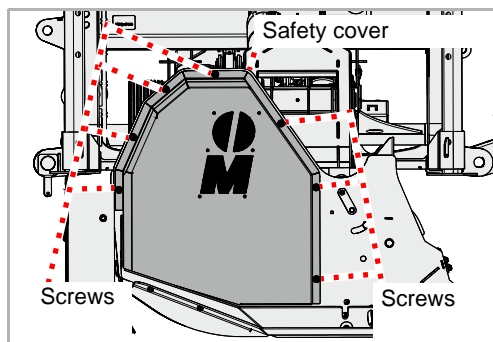
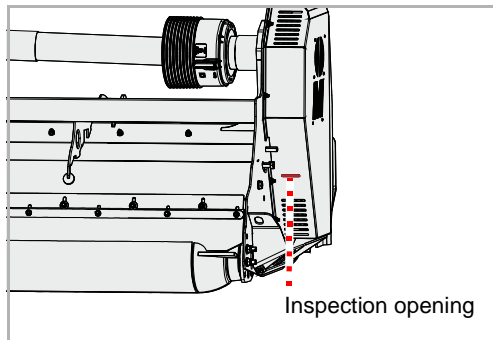

The drive belt is tensioned by a spring. If the V-belt is not sufficiently tensioned, it must be retensioned. If there are any tears or the V-belt is damaged, it must be replaced.

There is an inspection opening on the machine.

- ▶ Check the tension of the V-belt. When under a load of 6 kg, it must not be possible to push the V-belt through more than 10 mm.

- ▶ Remove the screws, remove the safety cover.
- ▶ Check the V-belt for damage
- ▶ Reassemble the safety cover
- ▶ Perform work on the opposite side of the machine

Maintenance

Tensioning

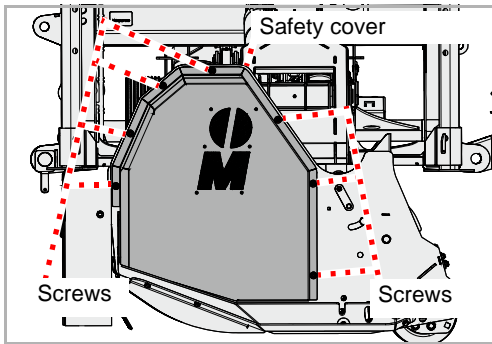

- ▶ Remove the screws, remove the safety cover.

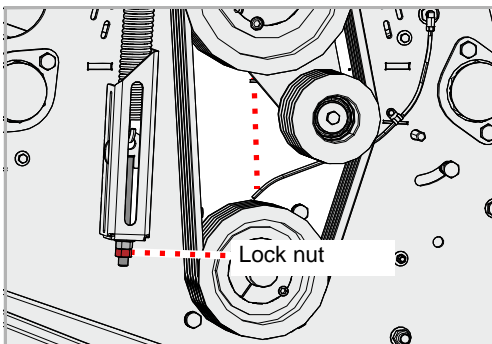

- ▶ Loosen the lock nut

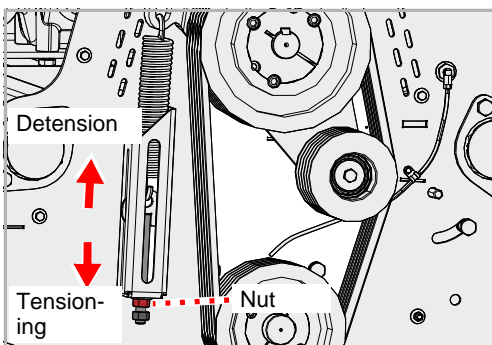

- ▶ Use the nut to set the drive belt tension as required
- ▶ Retighten the lock nuts

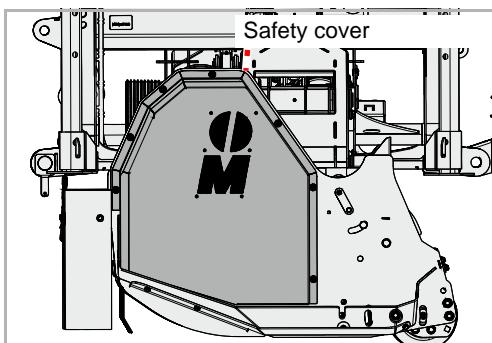

- ▶ Reassemble the safety cover

If the V-belts also need to be tensioned on the other side:

- ▶ Tension V-belts on the other side

Replacement

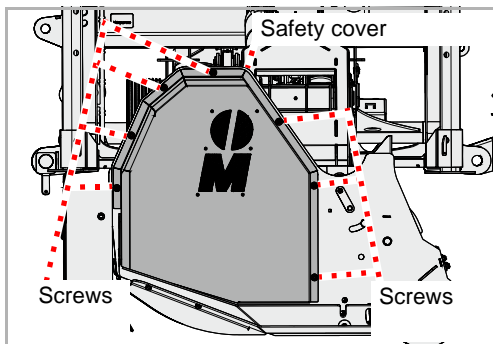

If there are any tears or other damage on the V-belt, it must be replaced.

- ▶ Remove the screws, remove the safety cover.

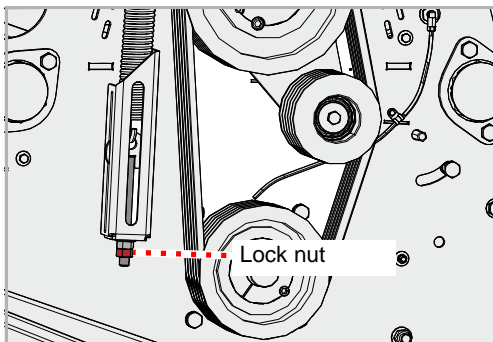

- ▶ Loosen the lock nut

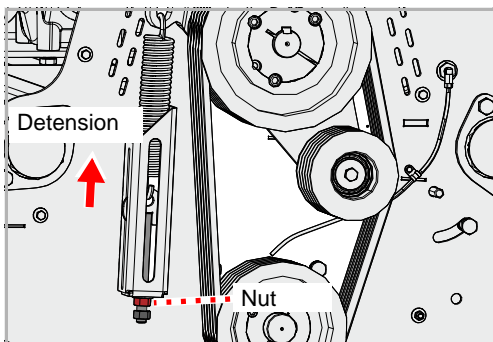

- ▶ Slacken the drive belts using the nut

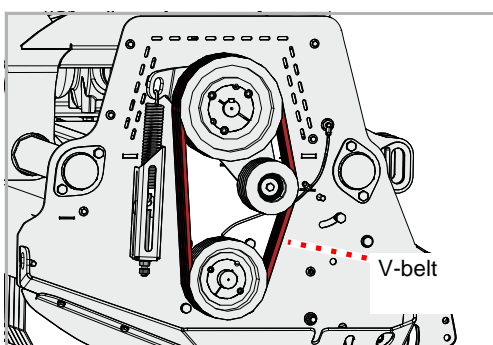

The drive belt unit consists of five narrow drive belts.

- ▶ Remove the old V-belts.
- ▶ Fit the new V-belts
- ▶ Check the V-belt for correct positioning
- ▶ Tension the V-belt
- Section »Tensioning«, Page 110
- ▶ Reassemble the safety cover

If there are also cracks or other damage on the V-belt on the other side:

- ▶ Exchange V-belt on the other side

Maintenance

Runners

As required

The runners protect the machine from direct contact with the ground. If they are not replaced in good time, the housing of the machine will be damaged.



Secure the machine

Work can only be carried out on a machine secured against rolling away and dropping. To prevent dropping, for example, permitted and correctly dimensioned support legs can be used.

If the machine is not secured against rolling away and lowering, serious or fatal accidents could result.

Replacement

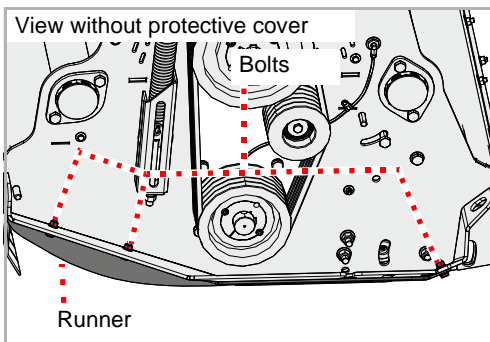

Runners are fitted on each side.

- ▶ Undo nuts, remove screws and washers.
- ▶ Remove old runner
- ▶ Fit new runner
- ▶ Fit new screws and washers
- ▶ Secure screws with new nuts

If the runner on the other side is also worn:

- ▶ Replace the runner on the other side

2-Cut double-cut rotor

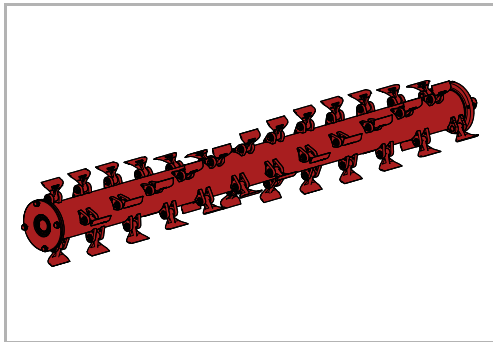

With the help of the 2-Cut double cut rotor, you can achieve a higher working speed at the same power. Or you can achieve the same work result with less power. The 2-Cut double cut rotor is in any case an efficient alternative to the standard cutting rotor.

Cutting bar

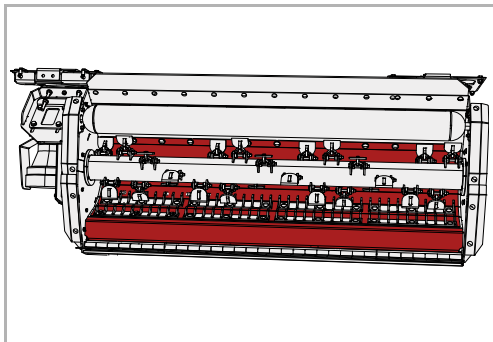

The degree of shredding can be altered using a cutting bar. You can use it to determine how finely the material should be shredded.

short chopping bar

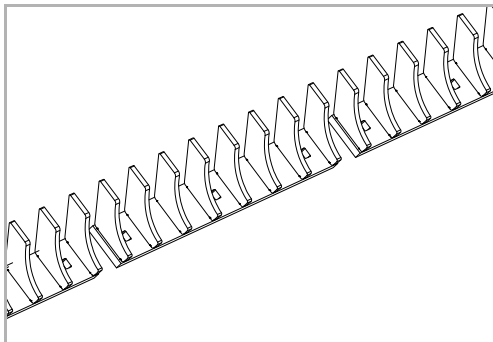

The short chopping bar optimises the material feed. This produces better cutting.

Scraper

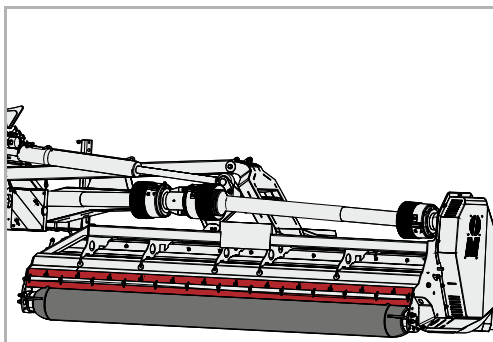

The scraper cleans the roller with each revolution. If the mulch is long or the weather conditions are unfavourable, this therefore prevents malfunctions caused by mulch blockages.

Accessory

Operating hours counter

An electronic operating hours counter displays the actual operating duration. This means that data can be recorded precisely and used, for example, for calculations.



Additional guard

When using of the machine in particularly sensitive areas, the use of an additional guard can be effective. The additional guard is fitted in front of the front stone guard on both sides of the machine.

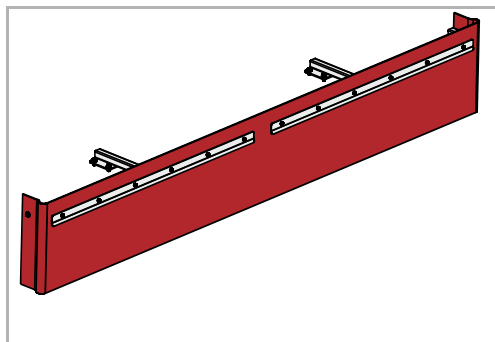

Individual control

A control valve allows the two sides of the machine to be lifted or lowered separately. This allows you to react flexibly to different ground contours.

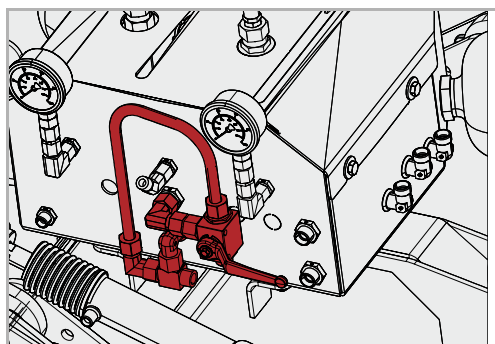

Fault elimination

Faults can often be eliminated quickly and easily. In the event of hydraulic problems, first check:

- Are the hydraulic hoses properly connected?
- Is the control valve at the tractor defect?
If so, contact your dealer.
- Is the hydraulic pump of the tractor defective?
If so, contact your dealer.

Before calling Customer Service, refer to the table below to check whether the fault is one you can eliminate yourself.

Fault	Cause	Remedy
Strong vibrations and high noise development	Tools are worn	Replace the tools
	One or more tools are missing	Replace tools
	Tools are damaged	Replace the tools
	Bearings for the rotor are worn	Have the bearings replaced
	Foreign bodies, such as wire, are wound around the rotor	Remove foreign bodies
	Tools have become loose	Tighten nuts on screws
	Speed of rotation of the PTO stub shaft is not set correctly	Set the correct speed of rotation on the PTO stub shaft
	Rotor not correctly counterbalanced	Check balancing and rebalance the rotor if necessary
Tools wearing quickly	The tools are working too deeply	Set correct working depth
Material cut too rough and cut material not distributed evenly	Drive speed too high	Reduce the drive speed
	The tools are working too deeply	Set correct working depth
	The tools are working too high	Set correct working depth
	V-belt worn	Replace V-belt set
	V-belt not correctly tensioned	Check V-belt tension and retension if necessary
	Speed of rotation of the tractor PTO stub shaft is too low	Increase the rpm
	Tools are worn	Replace the tools
	The machine is not standing parallel to the ground	Adjust the machine correctly
Rotor does not turn	Rotor is blocked by a foreign body	Remove foreign bodies
	The PTO shaft is free-wheeling or the gear box is incorrectly assembled.	Have the free running state correctly assembled

Fault elimination

Fault	Cause	Remedy
PTO shaft rotating, rotor is not	V-belt torn	Replace the V-belt
Unusual noises from the PTO shaft	Insufficient lubrication	Lubricate the PTO shaft
Gear box overheating	Incorrect oil specification	Change oil and select oil with correct specification
	Oil too old	Change oil
	Oil level too low	Fill the oil to the lower edge of the inspection opening
	Machine overload	Maintain rpm in correct region, adjust driving speed to suit the work, maintain performance area (avoid excessively heavy growth or excessively thick branches)
High wear on V-belts V-belts running hot Power transmission not optimal	The tools are working too deeply and touching the ground	Set correct working depth
	Pulleys not aligned in parallel	Have pulleys correctly aligned
	V-belt is worn	Replace the V-belt
	V-belt is not correctly tensioned	Check the tension jack
Loss of oil at gear box or at centre bearing	Sealing rings worn or damaged	Have sealing rings replaced
Drive elements broken	Machine was started up abruptly or is blocked by foreign bodies	Have defective drive element replaced. Start the machine up slowly.

Disposal of the machine

When the service life of your machine is over, it must be disposed of properly. Please observe currently valid disposal regulations.

Metal parts

All metal machine components can be sent for metal recycling.

Plastic parts

All plastic parts are marked and can be recycled.

Oil

Collect fluid from the hydraulic system in a suitable container and dispose of at a used oil collection facility.

EU-conformity declaration

EC Directive
2006/42/EG

Müthing GmbH & Co. KG Soest
Am Silberg 23
D-59494 Soest

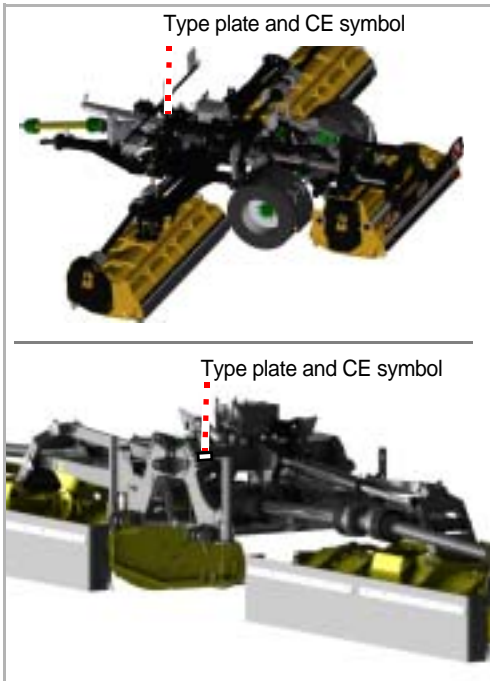

assumes sole responsibility for declaring that the following product complies with EC Directive 2006/42/EC:

MU-Pro/F Vario, MU-Pro/F Trail Vario and additional equipment

Assorted samples of harmonized standards:

- DIN EN ISO 4254-1
- DIN EN ISO 4254-12
- EN 13524

Soest, 28.10.2022

Andreas Rohde
CEO and authorised person for compiling technical documentation

Copy of the type plate/serial number entry

Machine type: Flail mower
Maschine Name:
Working width:
Serial number:
Year of construction:

UK Declaration of Conformity

UKCA

Müthing GmbH & Co. KG Soest
Am Silberg 23
D-59494 Soest
Germany

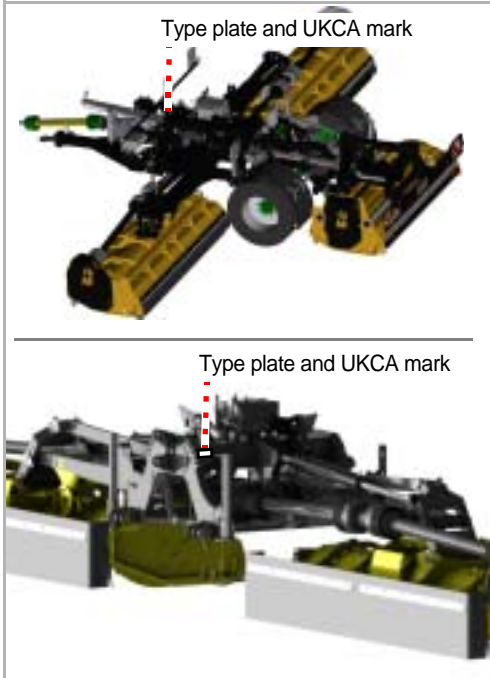

declares under sole responsibility that the machine conforms with the following directives:

- Supply of Machinery (Safety) Regulations 2008

Assorted samples of harmonized standards:

- BS EN ISO 4254-1
- BS EN ISO 4254-12
- BS EN 13524

Machine designation	MU-Pro/F Vario, MU-Pro/F Trail Vario and additional equipment
---------------------	---

The special technical documents corresponding to the machine have been created according to Annex VII, Part B.

Soest, 28.10.2022

Andreas Rohde
CEO and authorised person for compiling technical documentation

Copy of the type plate/serial number entry

Type of machine:	Mulcher
Model:	
Working Width:	
Machine ID:	
Production Year:	

MU-Pro/F Vario / MU-Pro/F Trail Vario

Index

A			
Accessory	113		
2-Cut double-cut rotor	113		
Additional guard	114		
Cutting bar	113		
Individual control	114		
Operating hours counter	114		
Scraper	113		
short chopping bar	113		
Wear insert	113		
Adjusting			
Working width	46		
air pressure brake system			
Cancelling braking effect	45		
Ankuppeln			
Variante gezogen	120		
Anschließen			
Elektrik	42		
assembly	25		
C			
Care	70		
Centre of gravity	17		
Cleaning	70		
compressed air			
Connecting	43		
Connecting			
compressed air	43		
Hydraulics	41		
Coupling			
Drawn variant	32		
Separated variant	35		
Cutting bar			
Hydraulic	50		
Mechanical	50		
Cutting level	49		
D			
Depositing cut material	51		
Direction information	15		
Display			
Drawn variant	48		
Drawn variant			
Coupling	32		
Display	48		
PTO shaft	33		
Druckluftbremsanlage			
Bremswirkung wiederherstellen	120		
E			
Elektrik			
Anschließen	42		
Employer	8		
F			
Fault	115		
Features	24		
H			
Hydraulics			
Connecting	41		
I			
Index	120		
Instruction	8		
L			
labels, see warning signs			
Lubricate bearings	96		
M			
Machine			
Storing	89		
Maintenance			
General information	91		
Maintenance intervals	94		
Overview of lubrication points	97		
Safety	90		
Mulching			
Drawn variant	62		
Separated variant	63		
P			
Parking	71		
Separated variant	80		
Pictograms	9		
Protective procedure			
Oils or lubricants	91		
R			
Range of application	23		
Hammer flail	23		

S

Safety	10
Agricultural training	15
Altered driving and braking behaviour	19
Care and maintenance intervals	21
Care and maintenance work	21
Centre of gravity	17
Check the screwed connections	22
Cleaning	22
Coupling	16
Proper use	23
Putting the machine into operation	19
Riding on the machine	19
Uncoupling the machine	21
Warning signs	10
Welding work	22
Schneidgutablage	120
Scope of delivery	31
Screwed connections	93
Separated variant	
Coupling	35
Lower link	38
PTO shaft	39
Top link	38
Setting down the machine in a secure position	71
Switching on	69
Symbols	9

T

Target group	8
Task	68
Technical specifications	27
Tightening torques	
General	93
Transport position	
Drawn variant	58
Separated variant	59
Transport without coupling	61

V

Variante aufgelöst	
Gelenkwelle	120
Oberlenker	120

W

Warning signs	10, 60
Drawn variant	11
Meaning	13
Separated variant	12
Working width	46

