



OPERATION MANUAL

EN | Original

MU-FM/S

FROM PRODUCTION 2012

EDITION 11.2022

REFERENCE NUMBER MU-FM-S_BA_12_EN_2022-11

Machine identification

In order for your dealer to assist you as efficiently as possible, you will need to provide some information about your machine.

Please enter the information here.

Designation

Working width

Weight

Machine number

Additional equipment

Dealer's address

Manufacturer's address

Müthing GmbH & Co. KG Soest
Am Silberg 23
59494 Soest
Germany

Handover declaration

- Fill out this sheet with your dealer.
- Then separate this sheet from the operating manual and send it to the manufacturer within 10 days of delivery. Only in this way will the guarantee be effective from the date of delivery

To
Müthing GmbH & Co. KG
Am Silberberg 23
59494 Soest
Germany

I have bought the machine described below from Müthing GmbH & Co. KG Soest, and confirm full delivery and handover of the machine including the operating manual and spare parts list, as well as training in operating the devices with safety instructions and warning information from your dealer.

I confirm additionally that I have read and understood the operating manual and am in agreement with the information contained therein. This applies in particular to the chapter Safety.

Client

Name		First name	
Address			
Post code		Town/city	
Telephone		Fax	
E-mail		Date	

Machine

Machine	MU-	Serial number	
Working width		Gear-box	
Rigid mounting		Non-rigid mounting	
Year of construction		Delivery date	
Delivered by			

Signature of client

Signature and stamp of sales partner

Handover declaration

Handover declaration – Copy

– This sheet remains with the client in the operating manual

I have bought the machine described below from Mühling GmbH & Co. KG Soest, and confirm full delivery and handover of the machine including the operating manual and spare parts list, as well as training in operating the devices with safety instructions and warning information from your dealer.

I confirm additionally that I have read and understood the operating manual and am in agreement with the information contained therein. This applies in particular to the chapter Safety.

Client

Name		First name	
Address			
Post code		Town/city	
Telephone		Fax	
E-mail		Date	

Machine

Machine	MU-	Serial number	
Working width		Gear-box	
Rigid mounting		Non-rigid mounting	
Year of construction		Delivery date	
Delivered by			

Signature of client

Signature and stamp of sales partner

Handover declaration	3	Cleaning and care	42
Handover declaration – Copy	5	Cleaning	42
About this operating manual	8	Care	42
Target group	8	Parking and storage	43
Safety	8	Setting down the machine in a	
Instruction	8	secure position	43
Other applicable documents	8	Storing the machine	47
Symbols	9	Maintenance	48
Safety	10	For your safety	48
For your safety	10	General information	49
Warning signs	10	Maintenance intervals and setting work	52
Definitions	13	Lubricating work	53
Who is allowed to operate the machine?	13	PTO shaft	55
Coupling	14	Transmission oil	56
Centre of gravity	15	Tools	58
Road transport	17	V-belt	59
Putting the machine into operation	17	Runners	62
Uncoupling the machine	19	Accessory	63
Care and maintenance	19	Warning signs with lighting device	63
Further regulations	20	Wear insert	63
Familiarising yourself with the machine .	21	short chopping bar	63
Range of application of the machine	21	Operating hours counter	64
Features of the machine	22	Fault elimination	65
Designation of components	23	Disposal of the machine	67
Technical specifications	24	EU-conformity declaration	68
Delivery and assembly	26	EC Directive	
Checking the scope of delivery	26	2006/42/EG	68
Coupling the machine	27	UK Declaration of Conformity	69
Coupling the tractor	27	UKCA	69
Hydraulics	30	Index	70
Electrics	30		
Preparation	31		
Working width	31		
Driving on the road	32		
Locking pin	32		
Transport position	32		
Stop valves	33		
Lower link	34		
Warning signs [+]	34		
Transport without coupling	35		
Mulching	36		
Work position	36		
Task	39		

About this operating manual

Target group

This operating manual is intended for trained machine operators and persons who are otherwise qualified to carry out landscape work and who have received training in how to use this machine.

Safety

Familiarise yourself with the contents of this operating manual which are relevant for your activity before commissioning or assembling the machine. Always read through the safety instructions in the chapter "Safety" and observe the warning information in the individual chapters. In this way, you will achieve optimum work results and operational safety.

For the employer

Staff must be instructed in the safe handling of the machine before the initial commissioning. Untrained or unauthorised persons are not permitted to use the machine.

The following are included in this training:

- Checking that staff possess the necessary requirements for safely handling the machine.
- Handing out the operating manual and the other relevant and applicable documents or an intensive course of training which, in particular, includes the safe handling of the machine.

Regular instruction sessions

Instruct your staff regularly, but at least once a year, concerning the basic procedural measures for safely handling the machine.

Instruction

You will receive training from your dealership concerning using the controls, safe operation and care of the machine. Commissioning without first receiving training is not permitted.

Other applicable documents

In addition to the operating manual, other documents also form an integral part of the machine:

EU-conformity declaration	Integral part of this operating manual → Chapter »EU-conformity declaration«, Page 68
Spare parts list	Integral part of the delivery with this machine
PTO shaft operating manual	Integral part of the delivery with this machine

About this operating manual

Symbols

In order to make this manual clear and easy to read, we have used various symbols. They are explained below:

- A bullet point accompanies each item in a list
- ▶ A triangle indicates operating functions which must be performed
- An arrow indicates a cross-reference to other sections of this manual
- [+] A plus sign indicates an accessory that is not included in the standard version.

Pictograms

We have also used pictograms to help you find instructions more quickly:



The warning triangle indicates warning information. Failure to observe these safety instructions can result in:

- Moderate to serious injury
- Fatal injury

You will find the warning information associated with individual operations, where it is important to observe the warning information before these operations are carried out.

You will also find safety instructions in the chapter »Safety« which cannot be assigned to any particular operations, but increase your ability to work safely in different situations.



This sign indicates important instructions regarding the machine. Failure to observe these safety instructions can result in:

- Serious faults in the correct operation of the machine.
- Damage to the machine



This symbol indicates information, tips and instructions about operation.



This symbol indicates tips for assembly or adjustment work.



This symbol indicates examples that help you to understand the instructions better.

Parts in the text which refer to individual machines or to conditions have a colored background. After the colored section, the text then applies again to all machines. For example:

Only for MU-Farmer/S with pneumatic brake system

- ▶ Connect brake hoses
- ▶ Connect hydraulic hoses

Safety

For your safety

This chapter contains general safety instructions. Each chapter of the operating manual contains additional warning instructions which are not described here. Observe the safety instructions:

- In the interest of your own safety,
- In the interest of the safety of others
- To ensure the safety of the machine

Numerous risks can result from handling landscaping machines the wrong way. Therefore, always work with particular care and never under time pressure.

For the employer

Inform personnel working with the machine of these safety instructions at regular intervals and according to statutory regulations.

Warning signs

On the machine you will find labels that serve to ensure your safety. The labels must not be removed. If labels become illegible or begin to peel off, new labels can be ordered and attached in the appropriate places.

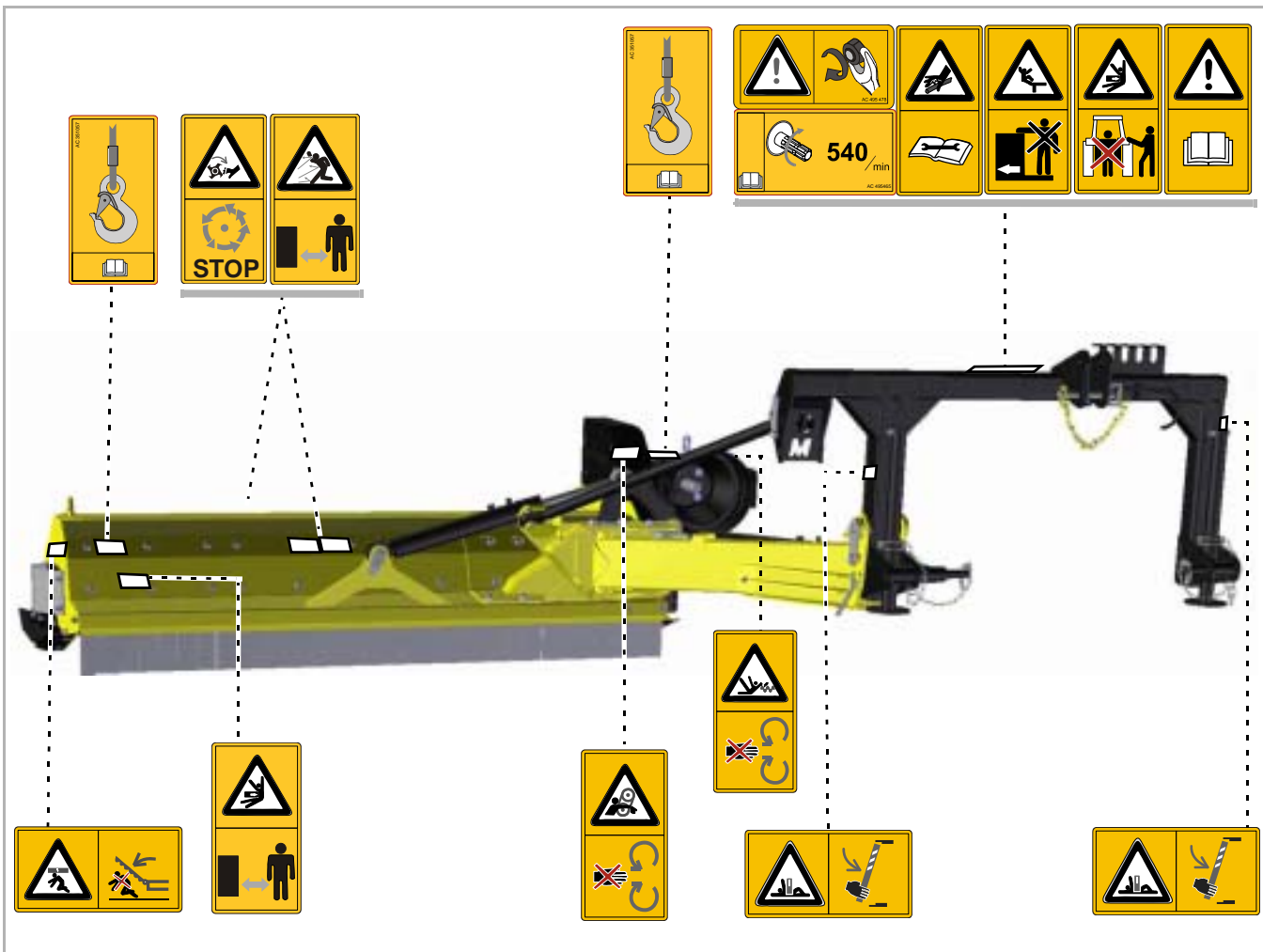

Meaning of warning signs



Read the operating manual carefully and follow the instructions
Commissioning of the machine must not take place before the operating manual has been read and understood. This particularly applies to safety instructions.



Do not stand between the tractor and the machine
Standing between the tractor and the machine with the engine running is prohibited, especially during coupling and uncoupling. The tractor must be additionally secured against rolling away.



Riding on the machine is prohibited
It can result in serious or even fatal injury.



Proceed with great care in the event of leaking hydraulic fluid
Do not look for leakage points without correct protection. Fine oil jets could penetrate eyes and skin under high pressure. Observe the corresponding safety instructions in the operating manual.



Do not remove protective devices
Never open or remove the protective devices while the tractor's engine is running. Never operate the machine without the protective device.



Be aware of the danger of being pulled in
There is a danger of being pulled into the PTO shaft in the event of inappropriate use.



Shackles
Only raise the machine using loading equipment at the points indicated.



Rotating and trailing machine parts

Only approach the machine when all machine parts have stopped moving.



Danger of objects being thrown out

During operation, there is a danger of objects such as stones being picked up and thrown out by the machine. Ensure that no persons are present in the hazard area.



Danger from moving machine parts

Nobody is permitted to remain within the hazard area during operation.



Caution, risk of tipping

The machine or parts can tip over. Attach the safety supports before you stand in the hazard area. To uncouple, use the struts provided and position on firm ground.



Do not stand in the slewing range

There is an extreme risk of injury within the slewing range from slewing or folding machine parts.

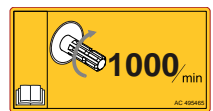

Check the rotational speed of the PTO stub shaft

Connect PTO shaft to a PTO stub shaft with an appropriate rpm. Always switch off the PTO stub shaft when working on the machine.



Retighten screws

After the first hours of operation, and as required, all screws must be checked and tightened if necessary. Vibrations might have loosened the screwed connections.

Definitions

All direction information is given in relation to the direction of travel of the machine:

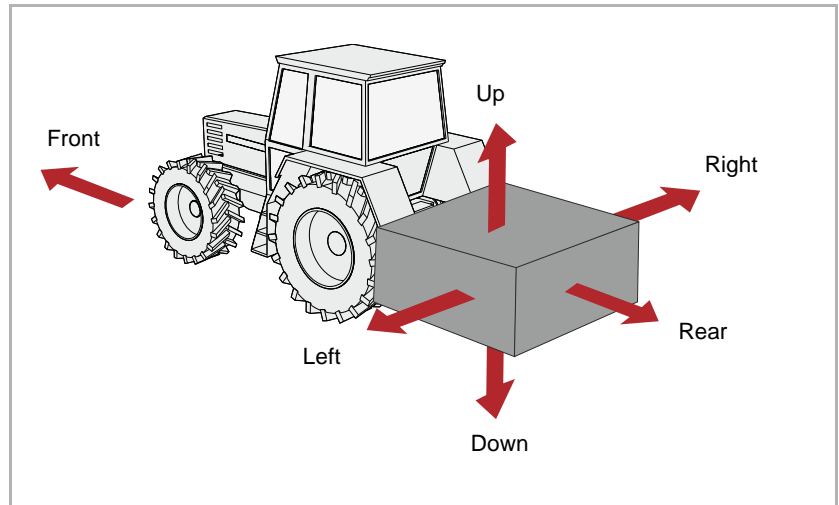

Who is allowed to operate the machine?

Only qualified personnel

Only qualified persons who have been informed of the dangers associated with handling the machine are permitted to operate, service or repair the machine. As a rule, such persons are trained and experienced in agricultural work or have been thoroughly trained in a similar fashion.

Coupling

Increased risk of injury

When the machine is being coupled to the tractor, there is an increased risk of injury. Therefore:

- Only couple the machine with the road chassis raised
- Secure the tractor against rolling away
- The tractor and machine must belong to the same category
- Never stand between the tractor and the machine during coupling
- Actuate the three-point power lift system slowly and carefully

Failure to observe these instructions can result in serious or fatal injury.

Connect electric wires or cables only after mounting the attachment

The electrical supply to the tractor must not be connected when the lighting equipment is being fitted. Short circuits and damage to the electronics are possible.

Only connect hydraulics at zero pressure

Only connect hydraulic hoses to the tractor hydraulic system if the tractor and machine hydraulic system is at zero pressure. A hydraulic system under pressure can trigger unpredictable machine movements.

High pressures in the hydraulic system

The hydraulic system is under high pressure. Regularly check all lines, tubes and screwed connections for leaks and externally visible damage. Only use suitable tools when looking for leaks. Rectify any damage immediately. Oil escaping under pressure may result in injuries and fires. In the event of injuries, seek medical attention immediately.

Color-coded hydraulic hoses

To prevent operating errors, plug sockets and plugs for hydraulic connections between the tractor and the machine must be color-coded. Wrongly connected hydraulic hoses can trigger unpredictable movements of the machine.

Centre of gravity

Observe the total weight, axle loads, tyre load-bearing capacity and minimum ballast specifications

The front or rear mounting of machines must not cause the carrier vehicle's permissible total weight, permissible axle loads, or tyre load-bearing capacity to be exceeded. The front axle must bear at least 20 % of the empty weight of the carrier vehicle to ensure steering capability.

You can calculate:

- Total weight
- Axle loads
- Minimum added weight

Data

For this calculation, some data is required out of the following documents and measurement results:

- Operating manual of carrier vehicle
- This operating manual
- Measurement results from carrier vehicle and attached machine

Data from the operating manual of the carrier vehicle:

- (A) unladen weight
- (B) front axle load
- (C) rear axle load
- (H) wheel base of carrier vehicle

Please take into consideration, for example, the weight of water in the tyres, accessories, etc.

Data from this operating manual:

- (D) Total weight of the machine when rear-mounted; the supporting load with the machines attached
- (E) Total weight of the machine when front-mounted
- (G) Distance between the lower link ball midpoint and the machine's centre of gravity when rear-mounted. With machines attached, $G=0$.

Data which you can determine by measuring:

- (F) Distance between the machine's centre of gravity when front-mounted and the front-axle midpoint
- (I) distance between the rear axle midpoint and the lower link ball midpoint. For rear-mounted machines between rear axle midpoint to drawbar coupling midpoint or hitch ball

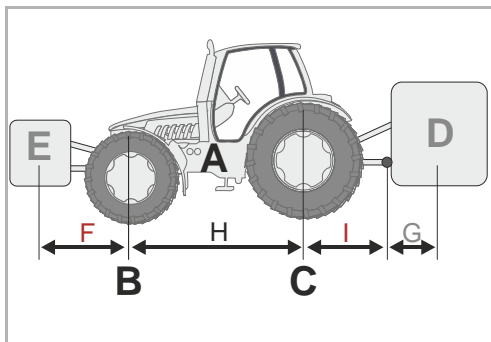

Safety

Calculation

The measured values can now be inserted into the formulas.

Ballast with front weights

Calculating the **ballast with front weights** on rear-mounted machines.

$$\text{Front ballast in kg} = \frac{D \times (I + G) - (B \times H) + (0,2 \times A \times H)}{F + H}$$

Ballast with rear weights

Calculating the **ballast with rear weights** on front-mounted machines.

$$\text{Rear ballast in kg} = \frac{(E \times F) - (C \times H) + (0,45 \times A \times H)}{H + I + G}$$

Front axle load

Calculating the **actual front axle load**

$$\text{Front axle load in kg} = \frac{E \times (F + H) + (B \times H) - D \times (I + G)}{H}$$

Total weight

Calculating the **actual total weight**

$$\text{Total weight} = E + A + D$$

Rear axle load

Calculating the **actual rear axle load**

$$\text{Rear axle load in kg} = \text{actual total weight} - \text{actual front axle load}$$

Tyre load-bearing capacity

Data on the tyre load-bearing capacity of the front and rear tyres can be found in the tyre manufacturer's documentation.

- The front tyre load-bearing capacity for two wheels is equal to twice the permissible tyre load-bearing capacity of a single front wheel.
- The rear tyre load-bearing capacity for two wheels is equal to twice the permissible tyre load-bearing capacity of a single rear wheel.

Summary

Check if the following conditions are met:

- The actual rear axle load is less than the permissible values for the axle load stated in the operating manual of the carrierer vehicle
- The actual total weight is less than the permissible values for the total weight stated in the operating manual of the carrierer vehicle
- The sum of the permissible rear wheel load capacity is higher than the real rear wheel load capacity
- The sum of the permissible front wheel load capacity is higher than the real front wheel load capacity

If all conditions are met, the machine may be attached to this carrier vehicle.



You can use a sufficiently large weigh-bridge to determine the total weight, the rear axle load and the front axle load by weighing.

Road transport

Make sure that the condition of the machine conforms to road traffic regulations

The machine must conform to current traffic regulations if you intend to drive it on public roads. This includes for example:

- Fitting lighting equipment, warning devices and protective devices
- Observing the permissible transport widths, transport weights, axle loads, tyre load-bearing capacity and total weights

The driver and owner of the vehicle are liable if traffic regulations are not observed.

Closing ball valves

If ball valves are provided on the hydraulic lines or the chassis cylinders, the ball valves must be closed for road transport. Accidental actuation of control devices on the tractor might otherwise cause movements in the machine. Accidents or damage to the machine may be caused as a result.

Check release cable for the quick-release coupling

Release cables must hang loose and must not, when in their lowered position, release the couplings of their own accord. Attached machines might otherwise come loose from the three-point linkage of their own accord.

Riding on the machine is strictly prohibited

People or objects must never be transported on the machine. Riding on the machine poses a risk to life and limb and is strictly prohibited.

Take altered driving and braking behaviour into account

Driving and braking performance is altered when the machine is attached to the tractor. Take the width and balancing weight of the machine into consideration, especially when cornering. A driving style which not adjusted to the road conditions can lead to accidents.

Drive at a suitable speed

Always adjust your driving speed to the road conditions. Driving at excessive speeds in poor road conditions may create extremely large forces, which will severely load or overload the tractor and the machine. Driving at unsuitable speeds can cause machine damage and lead to accidents.

Training required before commissioning

The machine must not be put into operation until the user has been given proper training by an employee of the dealer, a factory representative, or an employee of the manufacturer. Commissioning without training can lead to damage to the machine due to false operation or accidents can happen.

Ensure that the machine is in perfect working condition

Do not operate the machine unless it is in perfect working condition. Check all important components and replace any defective components before starting the machine. Defective components can cause damage to equipment and personal injury.

Putting the machine into operation

Do not remove the protective equipment

The protective equipment must not be removed or by-passed. Check all protective equipment before starting the machine. Unprotected machine parts can cause serious or fatal injury.

Riding on the machine is strictly prohibited

People or objects must never be transported on the machine. Riding on the machine poses a risk to life and limb and is strictly prohibited.

Height of the machine and overhead power lines

If a height of 4.00 m is exceeded when folding the machine in and out, the machine must not be folded in the vicinity of live overhead power lines. Danger of electrocution! Should the machine come into contact with a live overhead power line:

- Do not attempt to exit the tractor cabin
- Do not touch any metal parts on the tractor
- Do not create any conductive contact with the ground
- Warn all persons in the area not to approach the tractor or the machine
- Wait for help from professional emergency service personnel as power in the live overhead power line must first be switched off

Never climb onto the machine beneath live overhead power lines. The voltage can jump across even if the lines are not actually touching the machine.

Check the hazard area

Before driving off, folding out, and operating the machine and during operation, check its hazard area. Make sure that you have an adequate view. Do not begin work until the hazard area is cleared of any persons or objects. Information regarding the hazard area can be found in the corresponding chapter.

→ Chapter »Mulching«, Section »Task«, Page 39.

Parts could be ejected from the machine at high speed in certain circumstances. The hazard area, particularly in front of and behind the machine, must be cleared of any persons, animals or objects before starting.

Any use of the machine without verification of the hazard area can lead to serious or fatal accidents.

Retighten all nuts, bolts and screws

Nuts, bolts and screws should be checked at regular intervals and tightened if necessary. Screws can come loose unnoticed while operating. Damage to the machine or accidents may be caused as a result.

What to do in the event of a fault

In the event of a malfunction, shut down and secure the machine immediately. The fault may be eliminated immediately, or a specialist workshop must be assigned the task. Further operation of the machine can lead to damage to the machine or injury to persons.

Uncoupling the machine

Increased risk of injury

There is an increased risk of injury when uncoupling the machine from the tractor. Therefore:

- Secure the tractor against rolling away
- Never stand between the tractor and the machine during uncoupling
- Actuate the three-point power lift system slowly and carefully
- Make sure the machine is standing on a secure and level surface
- Do not disconnect hydraulic hoses until there is no pressure in the tractor and machine hydraulic system

Failure to observe these instructions can result in serious or fatal injury.

Care and maintenance

Observe the care and maintenance intervals

Observe prescribed intervals for maintenance checks and inspections specified in the operating manual. If these periods are not observed, this can lead to damage to the machine, poor quality of work or accidents.

Use original replacement parts

Many components have special properties that are essential for the stability and correct operation of the machine. Unsuitable spare parts or accessory parts or incorrectly performed repairs or changes can cause damage to the machine, accidents or serious injury.

Müthing strongly recommends using only approved original Müthing accessories and spare parts. Müthing can guarantee the safety, reliability and suitability of these parts only.

Use of non-original Müthing spare parts shall invalidate any warranty claims.

When performing any care and maintenance work:

- Switch off the PTO stub shaft
- Depressurise the hydraulic system
- Whenever possible, uncouple the tractor
- Make sure the machine is standing securely. Provide additional support as required
- Do not use parts of the machine as climbing aids; use only secure steps, ladders or other means of access
- Secure the machine against rolling away
- Never reach into the V-belt while it is moving

It is only possible to guarantee work safety during care or maintenance work through observing these regulations.

Turn off the electrical supply

Prior to carrying out work on the electrical system, disconnect the system from the power supply. Systems supplied with electrical power can cause damage to equipment and personal injury.

Replace hydraulic hoses

Replace hydraulic hoses every six years. Hydraulic hoses can age without any externally visible damage. Defect hydraulic lines can lead to severe or fatal injuries.

Caution when cleaning with a high-pressure cleaner

The machine can be cleaned using either water or a steam jet. Only use a low pressure to clean bearings, fans, signal mixer units, plastic parts and hydraulic hoses. Excessively high pressures can cause damage to these parts.

Before carrying out welding work, disconnect the battery and alternator

Before carrying out any electric welding work on the attached machine, disconnect the tractor battery and the alternator. This avoids damage to the electrical system.

Tighten all screwed connections

All screw connections that are released during maintenance and repair work must now be retightened. Loose screwed connections can cause bolts to undo without you noticing during your work. As a result, machine parts can become detached. Otherwise, this may result in severe injury or damage to equipment.

Further regulations

Observe the regulations

In addition to these safety instructions, observe the following:

- Accident prevention regulations
- Generally recognised safety regulations, occupational health requirements and road traffic regulations
- Information and instructions in this operating manual
- Operation, maintenance and repair instructions

Familiarising yourself with the machine

This chapter contains general information on your machine as well as information on:

- Range of application
- Features
- Designation of components
- Technical specifications

Range of application of the machine

The machine may only be used for its intended agricultural or associated purpose, depending on the type of tool with which it is equipped.

Tool	Purpose
Carbide M shackle flails	To cut grass, other growth or sections up to a maximum of 2 cm diameter. The shackle flails can deviate sideways. As they are made from carbide, the flails can be used for longer and need to be replaced less often.

Since the conditions of use are very varied, the user must pay particular attention to the machine's performance limits. The machine must be switched off immediately if there is any indication of overstress.

Proper use

The machine should only be used for the designated work as described in this operating manual. Any application other than or beyond this is considered improper use.

Examples of improper use:

- Transporting persons or objects
- Cutting of any products other than those specified or those of a similar nature

→ »Range of application of the machine«

- Transferring power to other objects
- front attachment
- Working depths under 25 mm clearance from ground
- Any type of ground work
- Use of the machine in a position in which the tools do not point towards the ground, for example in a vertical position

The manufacturer and dealers are not liable for damage caused by improper use. The risk is borne solely by the user.

Familiarising yourself with the machine

Features of the machine

Robust housing in optimised form

The housing is particularly robust for heavy use and is designed in an optimised form.

swivel arm

The machine is equipped with a swinging arm which can be hydraulically operated from the tractor, to change from the work position to the transport position.

Power transmission

Power is transmitted to a gear box via a PTO shaft. From there, the rotor is driven via V-belt.

Safety

The machine is constructed in accordance with EU regulations, for maximum possible safety of operation. The machine bears the CE mark and the UKCA mark.

Familiarising yourself with the machine

Designation of components

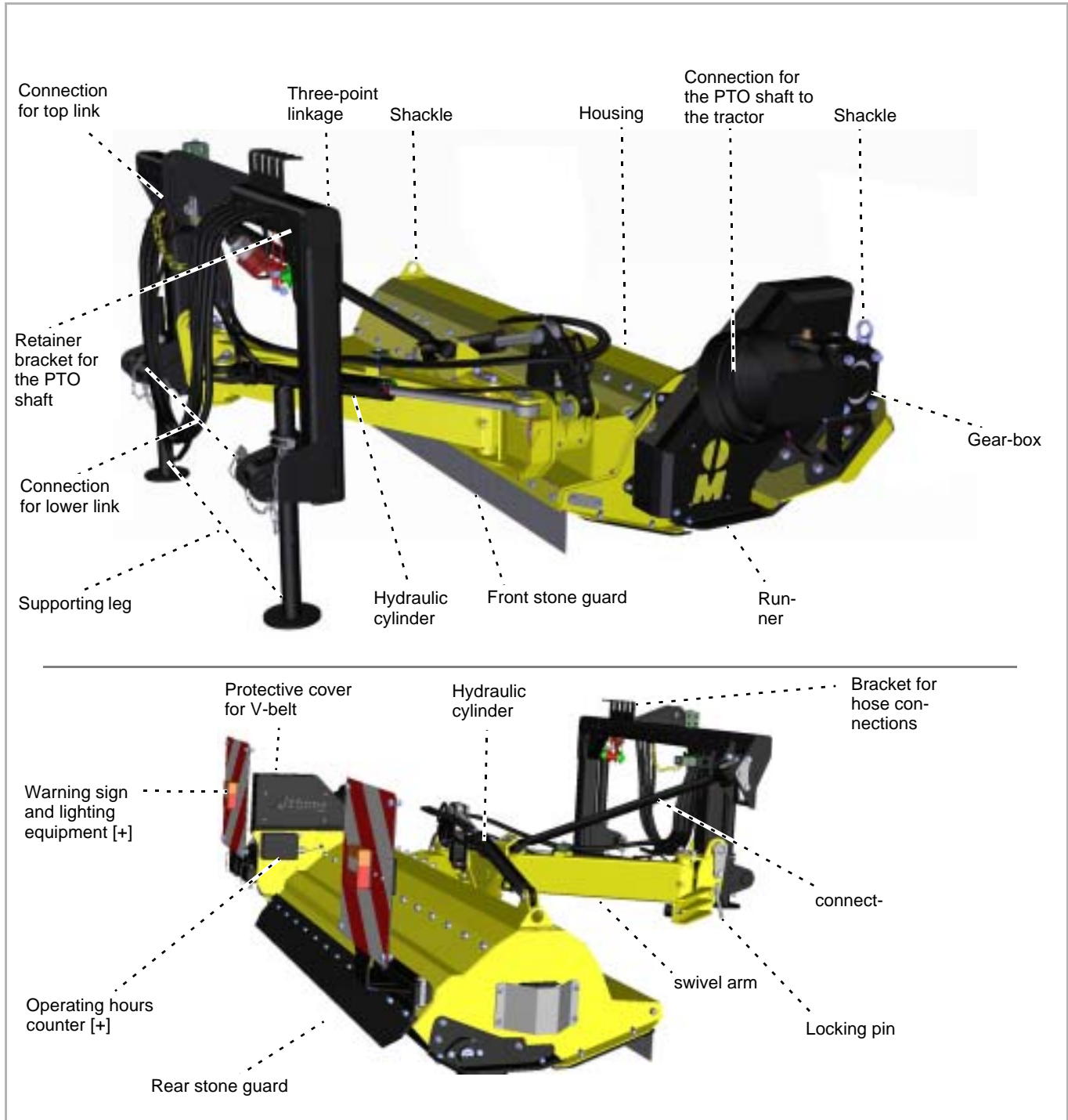

Familiarising yourself with the machine

Technical specifications

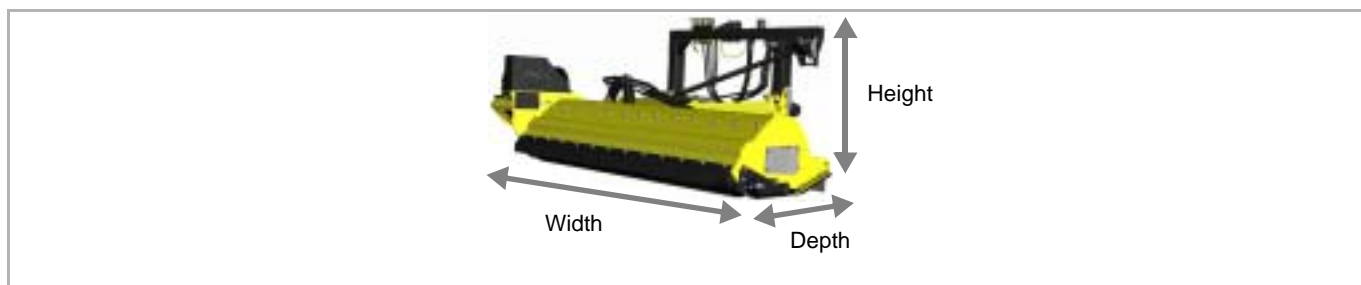

	MU-FM/S 120	MU-FM/S 140	MU-FM/S 160
Height [m]			
In work position	0.95	0.95	0.95
In transport position, 90°	2.10	2.10	2.10
In transport position, 0°	1.30	1.30	1.30
Width [m]			
In work position	3.00	3.00	3.00
In transport position, 90°	1.36	1.36	1.36
In transport position, 0°	2.13	2.13	2.13
Depth [m]			
In work position	1.85	1.85	1.85
In transport position	1,56	1,56	1,56
Working width [m]			
In work position	1.20	1.40	1.60
Total weight [kg]			
Depending on equipment level, approx.	325	345	365
Centre of gravity (dimension G)			
Depending on equipment level, approx.	1.12	1.12	1.12
Rotational speed of rotor [rpm]			
PTO stub shaft 540 RPM	2900	2900	2900
Power requirement [kW]			
Minimum	22	22	22
Maximum permitted	33	33	33
Tractor weight [kg]			
Minimum	1000	1100	1200
Working depth [mm]			
Adjustable	21 / 36 / 50	21 / 36 / 50	21 / 36 / 50
Number of tools			
Carbide M shackle flails	20	24	28
Lubricants			
Transmission oil	SAE 90 EP	SAE 90 EP	SAE 90 EP
hydraulic oil	SAE 90 EP	SAE 90 EP	SAE 90 EP
Noise emission [dB(A)]			
In the workplace	< 80	< 80	< 80

Familiarising yourself with the machine

	MU-FM/S 120	MU-FM/S 140	MU-FM/S 160
Category			
Lower link category	I	I	I
Paint colors			
Yellow	RAL 1007	RAL 1007	RAL 1007
Black	RAL 9005	RAL 9005	RAL 9005
PTO shaft			
Model	GE2303	GE2303	GE2303

Delivery and assembly

Checking the scope of delivery

The machine is delivered completely assembled. If parts of the machine have not been assembled, please contact your dealer.

Do not assemble the machine yourself

Do not perform assembly work yourself since requirements for an orderly condition of the machine are :

- Observance of a sequence of worksteps
- Compliance with tolerances and torques

Incorrect assembly may result in damage to the machine or poor performance.



If parts are missing or have been damaged during transportation, please submit a claim immediately to your dealer, importer or the manufacturer.



Increased risk of injury

When the machine is being coupled to the tractor, there is an increased risk of injury. Therefore:

- Secure the tractor against rolling away
- The tractor and machine must belong to the same category
- Never stand between the tractor and the machine during coupling
- Actuate the three-point power lift system slowly and carefully

Failure to observe these instructions can result in serious or fatal injury.



Only attach the machine to the rear

The machine may only be attached to the rear of the tractor.
The machine could be damaged if front-mounted

Coupling the tractor

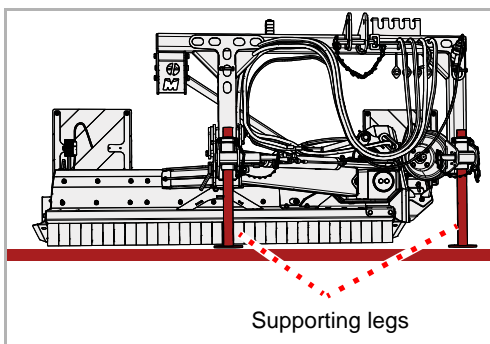

- ▶ Check that the machine is securely positioned. The support legs have been lowered and the machine housing is on the ground.
- Chapter »Parking and storage« paragraph »Setting down the machine in a secure position«, page 43

If the machine is not securely positioned:

- ▶ Secure the machine with suitable lifting gear and move into the correct position

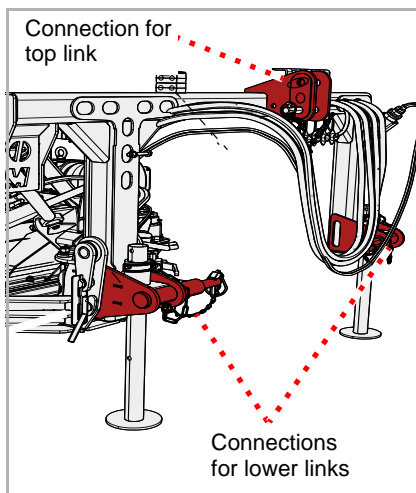

- ▶ Adjust both lower links on the tractor to the same height
- ▶ Connect the lower link according to the category of tractor and secure with linchpin
- ▶ Connect the top link according to the category of tractor and secure with linchpin

Coupling the machine

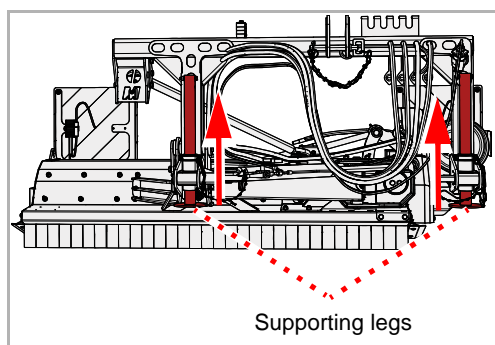

- ▶ Raise the machine slightly
- ▶ Open and remove the linchpin
- ▶ Push the parking legs upwards and fix them in the upper position with the folding cotter pin
- ▶ Adjust the lower link so that the machine has little play to the left or right

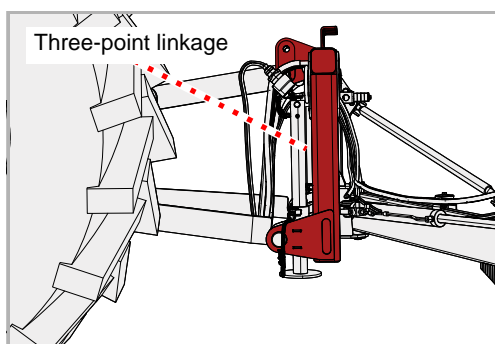

- ▶ Adjust the top link so that the three-point stand is vertical

PTO shaft

Connection to the machine

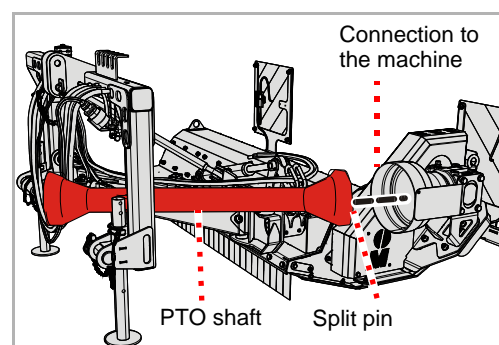

The PTO shaft has been adjusted to fit your tractor by your dealer.

Generally, the PTO shaft is already connected to the machine. If the PTO shaft is replaced or after maintenance work to the PTO shaft, it will be necessary to connect it to the machine.

- ▶ Carefully clean and grease the PTO shaft and connection to the machine
- ▶ Push the PTO shaft onto the connection to the machine and ensure that the cotter pin locks into place on the PTO shaft

Coupling the machine

Connection to the tractor



If the tractor is changed, the correct length of the PTO shaft must be checked. It is particularly important when checking the PTO shaft to ensure that the two halves of the PTO shaft continue to overlap at the position in which the PTO shaft is pulled apart furthest.

When changing the tractor, check that the PTO shaft is suitable for this tractor and if necessary, replace the PTO shaft and have it adjusted at a qualified specialist workshop.

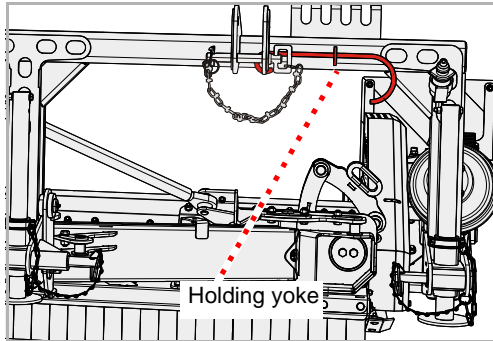

- ▶ Hold the PTO shaft and bring the holding yoke into the parking position



Do not place the attached PTO shaft in the holding yoke

The attached PTO shaft must not be in the holding yoke.

A PTO shaft lying in the holding yoke is damaged when driving on the road or when operating the lower link.

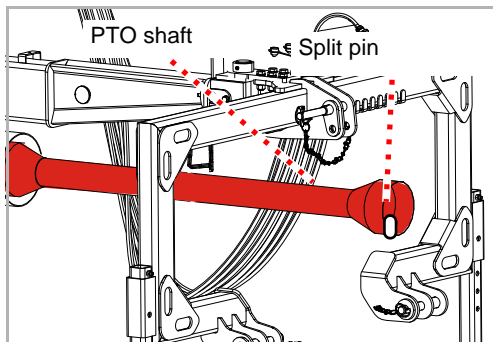

- ▶ Connect the PTO shaft to the PTO stub shaft of the tractor and ensure that the cotter pin is locked in place on the PTO shaft

Coupling the machine

Hydraulics

The following functions can be controlled:

Function	Color of dust cap
Moving the machine into the work position or the transport position.	Yellow
Tilting the machine	Red

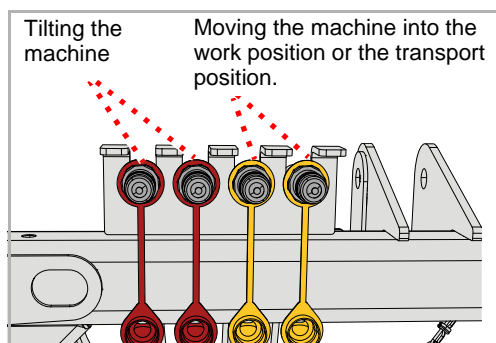

- ▶ Connecting the hydraulic hoses to one double-acting control valve each

Electrics

If present, attach the following plugs to the tractor for:

- The lighting equipment on the machine
- ▶ Check that the lighting equipment is working correctly

For indicators which are not signalling and are equipped with LEDs:



Depending on the tractor, the tractor's electrics may require regrouping in the electrical cable's plug connection. Please contact your dealer in this case.

Working width

The working depth can be adjusted in three stages. The optimal working depth for most applications is the middle setting.



Tools must not come into contact with the ground

Any contact with the ground could result in stones or other material not being held back safely by the stone guard.

Persons even outside of the hazard area could be injured by ejected material.



Check the number of bolts

The working depth setting must be secured with two bolts on each side.

If only one bolt is used on each side, the machine may be damaged by excessive wear.

- ▶ Secure the tractor against rolling away
- ▶ Raise the machine approximately 5 cm
- ▶ Loosen and remove bolt 1 and bolt 2
- ▶ Loosen bolt 3

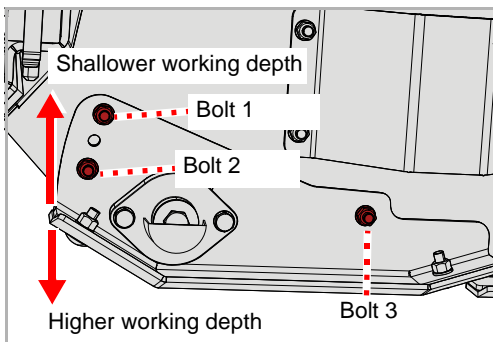
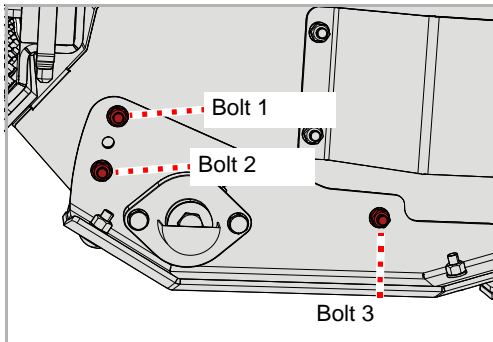

- ▶ Raise or lower the machine so that it is at the desired working depth
- ▶ Insert and tighten bolt 1 and bolt 2
- ▶ Tighten bolt 3 again
- ▶ Make the same adjustment on the opposite side of the housing.

Driving on the road

Locking pin

For transporting the machine, it must be secured with the locking pin after being coupled.



Secure the machine with the locking pin

For driving on the road, the machine must be secured with the locking pin.

Driving without the locking pin may result in the machine tipping out of the transport position. This can result in accidents.

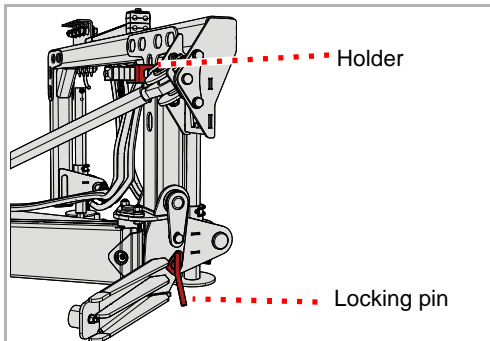

- ▶ Check that the machine is secured with the locking pin

If the machine is not secured with the locking pin:

- ▶ Remove the locking pin from the holder
- ▶ Insert the locking pin and secure with the linchpin

Transport position

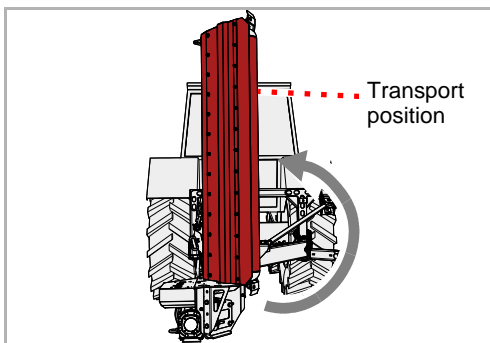

Machines, without warning signs and lightning equipment:

- ▶ Using the tractor's control device, fold the machine into the transport position

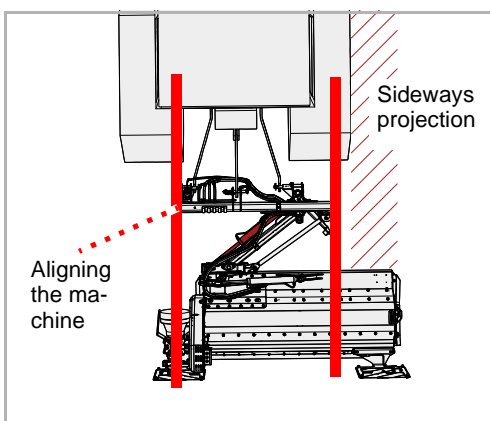

Machines with warning signs and lighting equipment [+]:

This position is required for driving on the road.

- ▶ Align the machine behind the tractor using the control device
- In this position, you can transport the machine on the road. Depending on the tractor, the machine may extend beyond the width of the tractor.

Stop valves



Close the stop valves, secure the control devices

Prior to road transport, the stop valves must be closed and the control devices on the tractor secured against inadvertent actuation. *If the shut-off valves are open and the control units on the tractor are not secured, the machine can fold out unintentionally in the working position while driving on the road. This can result in accidents.*

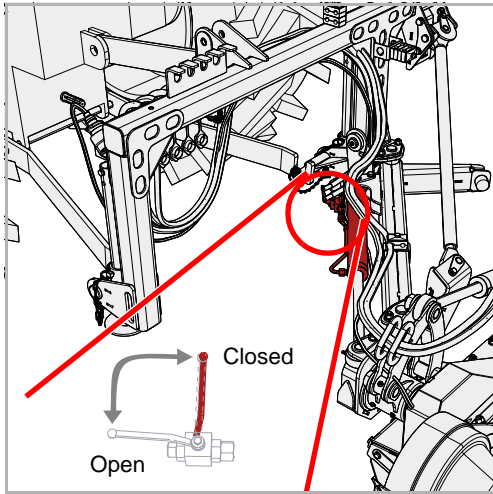

- ▶ Set the stop valve to “Closed” position on hydraulic cylinder 1

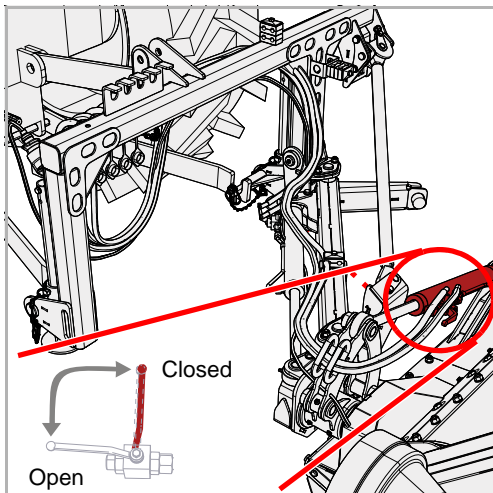

- ▶ Set the stop valve to “Closed” position on hydraulic cylinder 2
 - ▶ Secure the control devices on the tractor against inadvertent actuation
- Tractor operating manual

Driving on the road

Lower link

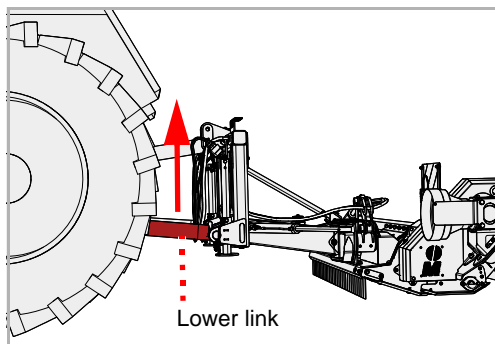

- ▶ Position the lower link over the three-point power lift of the tractor at a height which will enable the machine to be high enough for transport

Warning signs [+]

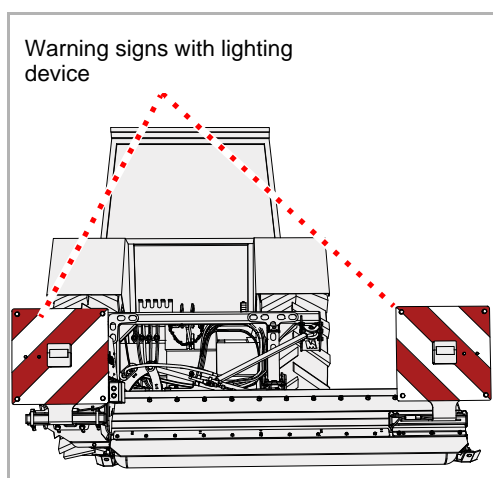

- ▶ Check lighting device for correct function

Transport without coupling

For transport on, for example, a trailer, the machine can be raised. Only use the designated points for attaching the lifting device. The machine must be securely positioned.

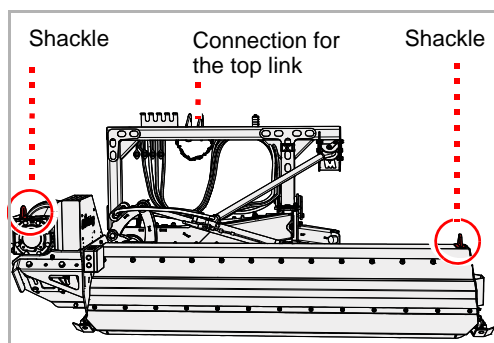

- ▶ Setting down the machine in a secure position
- Chapter »Parking and storage« paragraph »Setting down the machine in a secure position«, page 43
- ▶ Attach suitable lifting devices to the shackles and on the connection for the top link
- ▶ Raise the machine with suitable lifting gear and position on the loading bed
- ▶ Secure the machine against slipping

Mulching

Work position

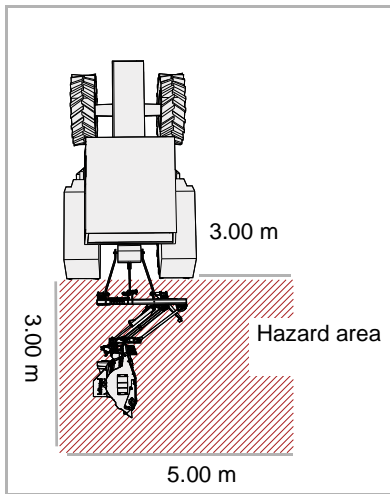

Check the hazard area

Before folding out the machine into the work position, check the hazard area. Make sure that you have an adequate view. Do not begin to fold it out into the work position until the hazard area is cleared of any persons or objects.

Folding out the machine without first checking the hazard area can lead to serious or fatal accidents.

The fold-out procedure is executed in several stages:

1. Open the stop valves
2. Fold out the machine into its work position
3. Remove the locking pin
4. Swivel out the machine

1. Stop valves

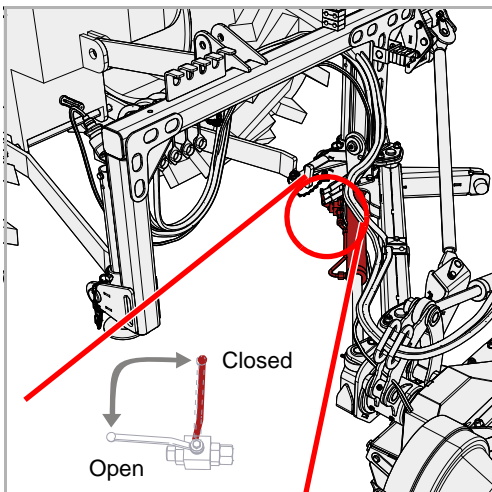

- ▶ Set the stop valve to "Open" position on hydraulic cylinder 1

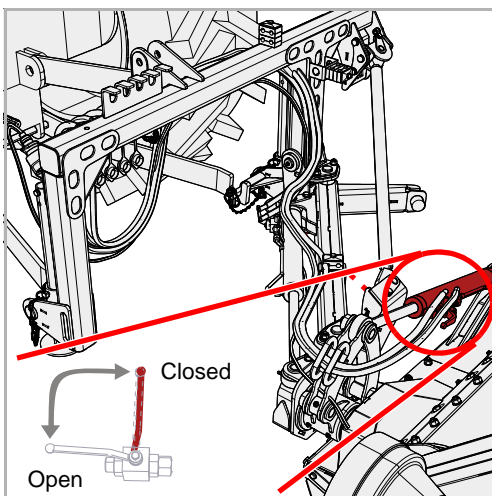

- ▶ Set the stop valve to "Open" position on hydraulic cylinder 2

2. Work position

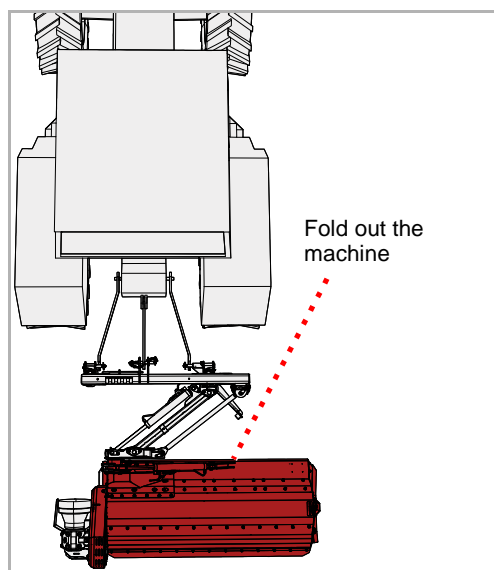

- ▶ Using the tractor's control device, fold out the machine into the work position

3. Locking pin

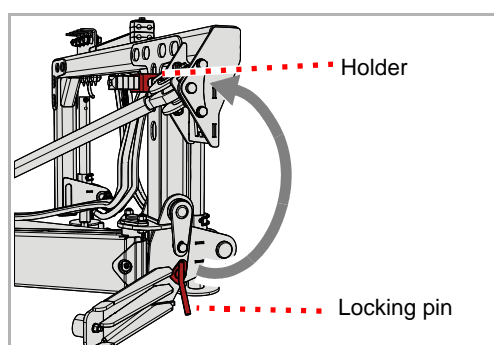

The locking pin must be removed for mulching.

- ▶ Remove the locking pin and insert into the holder
- ▶ Secure the pin with the linchpin

Mulching

3. Swivelling out

The position of the machine behind the tractor can be adjusted. This means that the machine can work either directly next to the tractor track or in the tractor track.



Do not swivel out when the machine is lowered.

When swivelling out, the machine must not be lowered to the ground. *If the machine is lowered to the ground when swivelling out, the machine will be damaged.*

The choice of position depends on the work to be carried out.

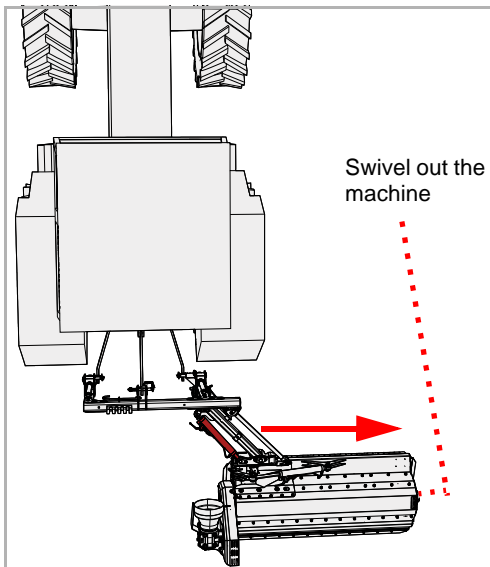
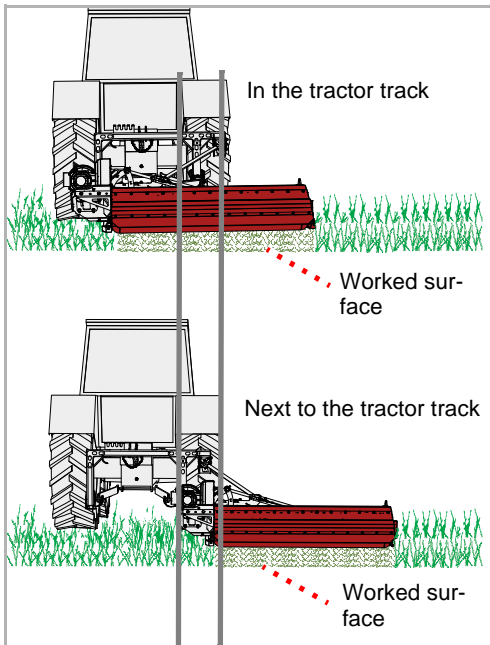

- ▶ Using the tractor's control device, swivel out the machine as required

Task

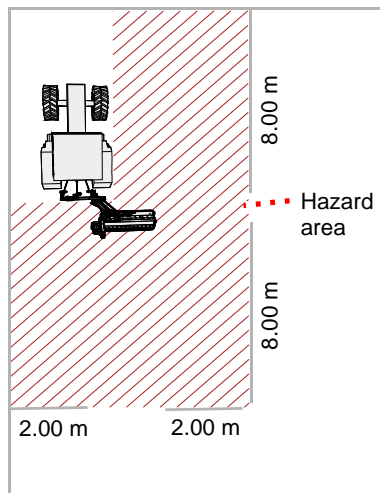

Check the hazard area

The hazard area in front of and behind the machine is 8 m, to the sides 2 m each. Before driving off, operating the machine and during operation, check its hazard area. Make sure that you have an adequate view. Do not begin work until the hazard area is cleared of any persons or objects.

Parts could be ejected from the machine at high speed in certain circumstances. The hazard area, particularly in front of and behind the machine, must be cleared of any persons, animals or objects before starting.

Any use of the machine without verification of the hazard area can lead to serious or fatal accidents.

Assess the dust exposure levels

If the ground and the material to be mulched are dry, you may be exposed to dust. Dust exposure can be avoided by taking into account the direction of the wind. If dust exposure cannot be avoided, you can protect yourself by wearing a dust mask. If these measures are not sufficient, use a tractor with an enclosed cab and a dust filter.

Dust exposure may lead to respiratory diseases.



Only work forwards

The machine may only be located in work position when moving forwards. The machine must be raised up when reversing.

A machine in work position when reversing could result in serious damage to the machine.

Mulching

Particular care should be taken by the operator when working with the mulcher. Working on ditches, overhangs or slopes are activities which tend to be particularly hazardous. We can only give general instructions, the actual situation must be evaluated by the operator.





Do not lean the machine forwards

The machine must not lean forwards when operating.
A machine that is leaning forwards could block and operate incorrectly.

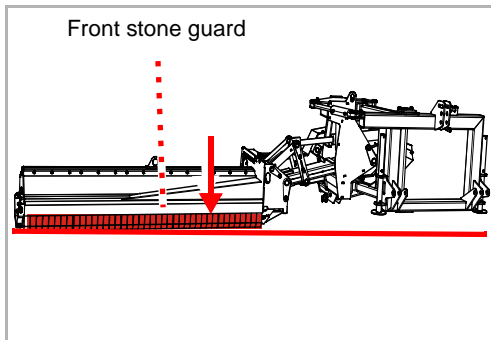

- ▶ Lower the machine using the lower links on the tractor until the machine is lowered to the ground. The front stone guard should be parallel to the ground.
- ▶ Set the tractor's control device for the lower links to floating position

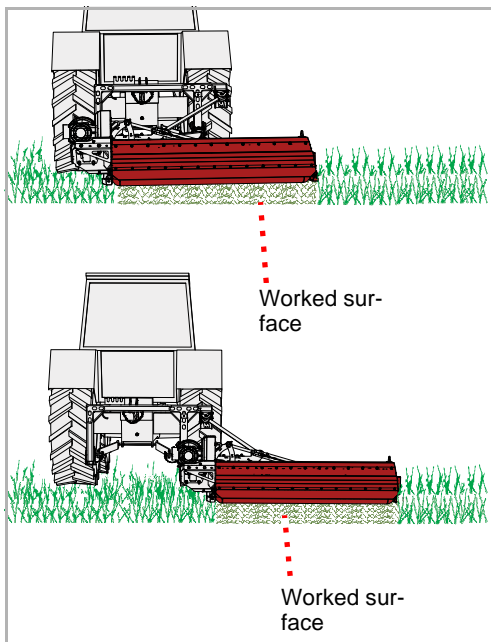

- ▶ Switch the PTO stub shaft into the work position and slowly bring the machine to the rated speed
- ▶ Then drive at low speed into the stock, increase speed slowly. Pay attention to the machine while doing this.

If the machine is working too hard:

- ▶ Reduce speed
- ▶ Drive at a suitable speed. The speed must be appropriate to the growth and the type of terrain.

Cleaning and care

Cleaning

A high-pressure cleaner, for example, can be used to clean the machine. Never point the water jet directly at the labels or type plate.



Only use low pressure to clean the bearings

Only use low pressure to clean the bearings.

Water penetration reduces the service life of the bearings

Care

To ensure the machine's long service life, we recommend applying a protective coating of oil after the end of the season and during storage.



Use only approved and biodegradable oil, e.g. rapeseed oil.

Setting down the machine in a secure position

The machine must be folded out before it can be set down.



Ensure that there are no unauthorised persons can enter the set-down location

If the machine is set down coupled or uncoupled on the tractor, the set-down location must be selected to ensure that no unauthorised persons can enter.

Persons could be injured by coming into contact with parts of the machine or by manipulating the machine.



Select the set-down location carefully

The set-down location must be relatively even and the ground must be solid.

Uneven or soft ground could result in the machine rolling away and becoming damaged.

Requirements on the set-down location:

- Horizontal, solid surface
- Sufficient room on all sides
- Protected against access by unauthorised persons, such as children

The machine is prepared for setting down safely in several stages:

1. Open stop valves
2. Fold out the machine into its work position
3. Insert the locking pin
4. Disconnect electrical cables and hydraulic hoses from the tractor
5. Remove PTO shaft
6. Lower the parking legs
7. Remove top link, undo lower link
8. Close the stop valves

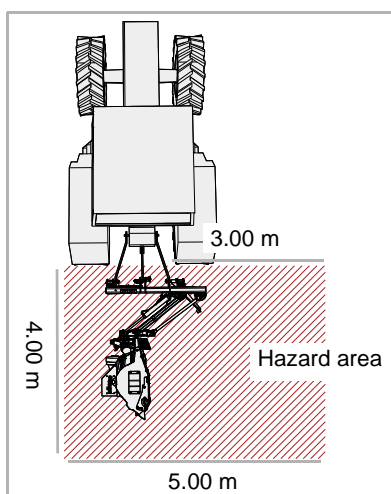

Check the hazard area

Before folding out the machine into the work position, check the hazard area. Make sure that you have an adequate view. Do not begin to fold it out into the work position until the hazard area is cleared of any persons or objects.

Folding out the machine without first checking the hazard area can lead to serious or fatal accidents.

Parking and storage

1. Stop valves

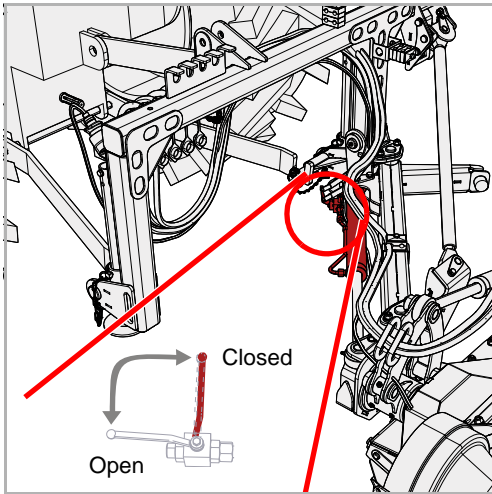

- ▶ Set the stop valve to "Open" position on hydraulic cylinder 1

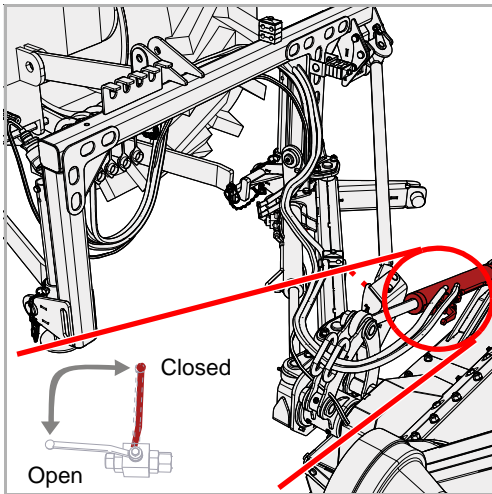

- ▶ Set the stop valve to "Open" position on hydraulic cylinder 2

2. Work position

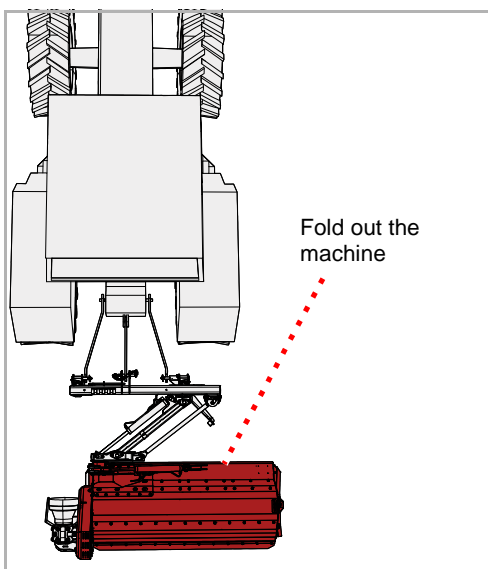

- ▶ Using the tractor's control device, fold out the machine into the work position

3. Locking pin

The machine must be secured with the locking pin when parked.



Secure the machine with the locking pin

The machine must be secured with the locking pin when parked. *If the machine is not secured with the locking pin, the three-point stand can tip over. This can result in accidents.*

- ▶ Check that the machine is secured with the locking pin

If the machine is not secured with the locking pin:

- ▶ Remove the locking pin from the holder
- ▶ Insert the locking pin and secure with the linchpin

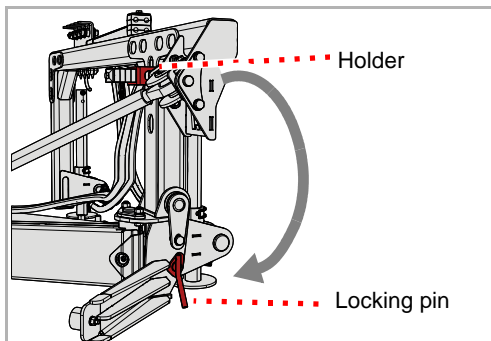

4. Electrics and hydraulics



Increased risk of injury

There is an increased risk of injury when uncoupling the machine from the tractor. Therefore:

- Secure the tractor against rolling away
- Never stand between the tractor and the machine during uncoupling
- Actuate the three-point power lift system slowly and carefully

Failure to observe these instructions can result in serious or fatal injury.

- ▶ Disconnect electrical cables and hydraulic hoses from the tractor's connections
- ▶ Place plug connection on the recess

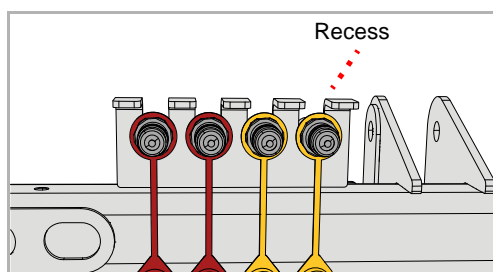

Parking and storage

5. PTO shaft

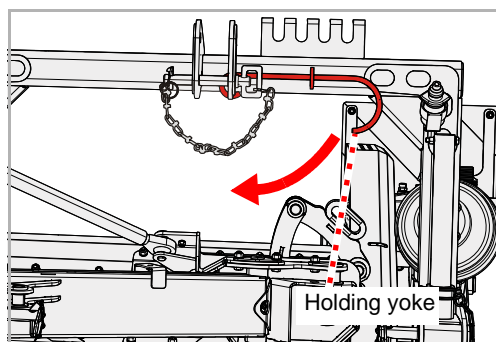

- ▶ Fold down the holding yoke
- ▶ Disconnect the PTO shaft from the tractor
- ▶ Insert the PTO shaft into the holding yoke

6. Parking legs

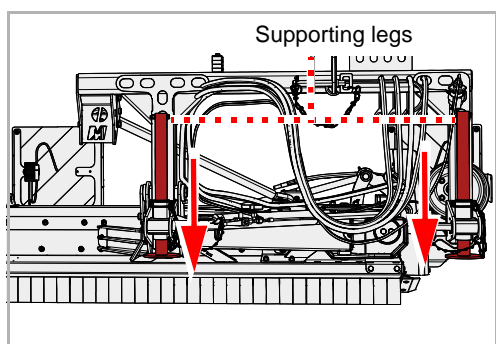

- ▶ Open and remove the linchpin
- ▶ Lower the parking legs downwards and fix them in the lower position with a linch pin.
- ▶ Lower the lower link until the top link is no longer under compressive or tensile strain

7. Top link, lower link

- ▶ Remove the top link
- ▶ Undo the lower link and lower

8. Close the stop valves

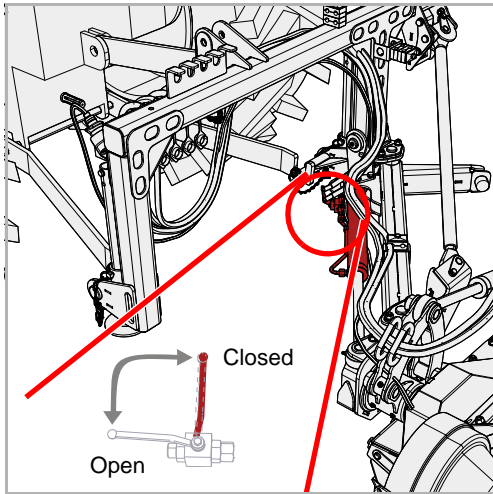

- ▶ Set the stop valve to “Closed” position on hydraulic cylinder 1

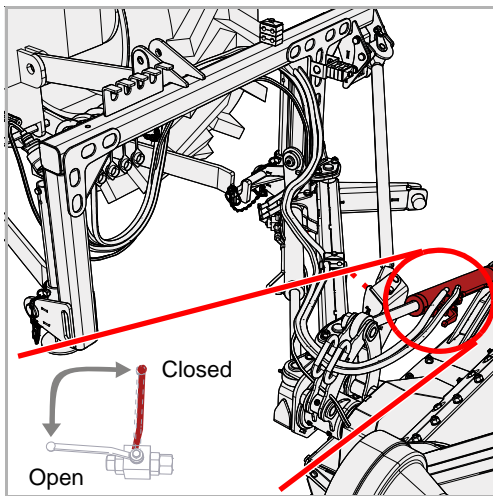

- ▶ Set the stop valve to “Closed” position on hydraulic cylinder 2
The machine is now safely set down.

Storing the machine

After cleaning, the machine should be stored in transport position in a dry location and on a level and stable surface.

→ Section »Setting down the machine in a secure position«, Page 43



Apply a protective coating of oil during storage. Use only approved and biodegradable oil, e.g. rapeseed oil.

→ Chapter »Cleaning and care«, starting at page 42

For your safety

Special safety instructions



Requirements for conducting maintenance work

Only perform the maintenance work if you have the required expert knowledge and suitable tools.

A lack of specialist knowledge or the use of unsuitable tools can cause accidents.

Protect the machine from being started up accidentally

If the machine is coupled, only carry out repair and maintenance work and only rectify malfunctions on it if:

- The PTO stub shaft is off
- The engine is switched off
- The ignition key is removed

Serious accidents may be caused if the machine starts accidentally.



Welding work

Welding work may only be carried out by persons trained in welding who also have specialist knowledge of repairing agricultural machinery. Welding work which negatively impacts the machine's construction is prohibited.

Incorrect welding work could impair or destroy the machine's function. If in doubt, contact your dealer before carrying out any welding work.

Use replacement parts with identical properties

Many components have special properties that are essential for the stability and correct operation of the machine.

When replacing components, dimensions, stability and material quality must be guaranteed. We recommend the exclusive use of original replacement parts.

Use of replacement parts which do not correspond to requirements could cause damage to the machine or impaired performance.

Protective measures when handling oils or lubricants

Additives in oils and lubricants may have adverse effects on health. Since the hazardous material code does not require any special identification, please always observe the following:



Avoid skin contact

Avoid skin contact with these materials.
Contact can result in skin damage.

Protect your skin

When handling oils and lubricants, protect your skin with lotion or wear oil-resistant gloves.
Oils can be hazardous to your health.

Do not use oils for cleaning

Do not use oils or lubricants to clean your hands.
Swarf and abraded material in these materials can also result in injuries.

Change out of soiled clothing

Change out of clothing that is heavily soiled with oil as soon as possible.
Oils can be hazardous to your health.



- Collect old oil and dispose of it in accordance with statutory regulations.
- If your skin becomes irritated by oil or lubricants, contact a doctor immediately.

General information

This information relates to general maintenance work. For all maintenance work, the machine must be locked in the work position. If it is necessary to put the machine in its transport position for maintenance work, you will see an appropriate reference in the maintenance instructions.



Working with the grease gun:

One or two strokes with the grease gun are sufficient for lubrication. If you feel resistance during the second stroke of the grease gun, do not complete it.

Too much grease will force the bearings apart. This could allow dust and dirt to enter the bearing, resulting in premature wear.

Maintenance

Fundamentals

The following table contains a brief explanation of the most important terms used for maintenance.

Task	Version
Greasing	<ul style="list-style-type: none">• Apply grease to the slide surfaces using a brush
Lubrication	<ul style="list-style-type: none">• 1 - 2 Unless specified otherwise, one or two strokes with the grease gun provide sufficient lubrication
Oiling	<ul style="list-style-type: none">• Unless otherwise specified, use only vegetable-based oil such as rapeseed oil• Mineral oils are not suitable• The use of used oil will endanger your health and is also strictly prohibited
Replacement	<ul style="list-style-type: none">• Replace the component in question according to the instructions in the »Maintenance« chapter
Check	<ul style="list-style-type: none">• An inspection may be required in conjunction with the replacement of the component in question
Observe the maintenance intervals	<ul style="list-style-type: none">• All information is based on average machine usage• In the case of heavy usage (e.g. contract work), shorten the maintenance intervals accordingly• Shorter maintenance intervals may also be required under extreme working conditions (e.g. heavy dust generation)

Screwed connections

Retighten screws

All bolts must be retightened:

- After the first hours of operation
- According to the frequency of use
- But at least once a season

General tightening torques

Tighten all screwed connections in accordance with the information in the table. If different tightening torques are necessary, they are specified in the chapter »Maintenance«. The minimum quality of the bolts is 8.8.

Bolt size	Quality of the bolts		
	„8.8“	„10.9“	„12.9“
	Tightening torques in Nm		
M6	9.9	14	17
M8	24	34	41
M10	48	68	81
M12	85	120	145
M16	210	290	350
M20	425	610	710
M24	730	1050	1220

Maintenance

Maintenance intervals and setting work

The information relates to average usage under the machine's normal operating conditions. Maintenance intervals are shorter for heavy usage, such as with hire companies, or for extreme operating conditions such as very dusty environments.

	After the first hours of operation	Once daily	After 30 hours of operation	After 75 hours of operation	Once per season	As required	In case of wear	grease / oil / lubricate	Check	Replacement	Cleaning
General											
Retighten all screws	•					•					
Visual inspection	•	•									
Bearing		•				•		•			
Pivots		•							•		
Hydraulics											
Hydraulic hoses Every 6 years										•	
Hydraulic hoses General						•	•			•	
Hydraulic cylinder		•		•		•		•	•		
Tools											
Fastenings on the rotor		•							•		
Condition, wear		•							•		•
Other											
Position of rotor		•						•			
Roller bearing		•						•			
Shafts and pins			•					•			
PTO shaft Protective cover		• •				• •		• •	• •	• •	• •
Transmission oil		•			•				•		•

Lubricating work

Lubricate bearings

The bearings must be lubricated regularly. Lubricate only with 1 - 2 strokes from the grease gun:

- According to the maintenance chart
- After heavy use
- But at least once a season

Bearings that require no maintenance must not be lubricated.

Maintenance

Overview of lubrication points

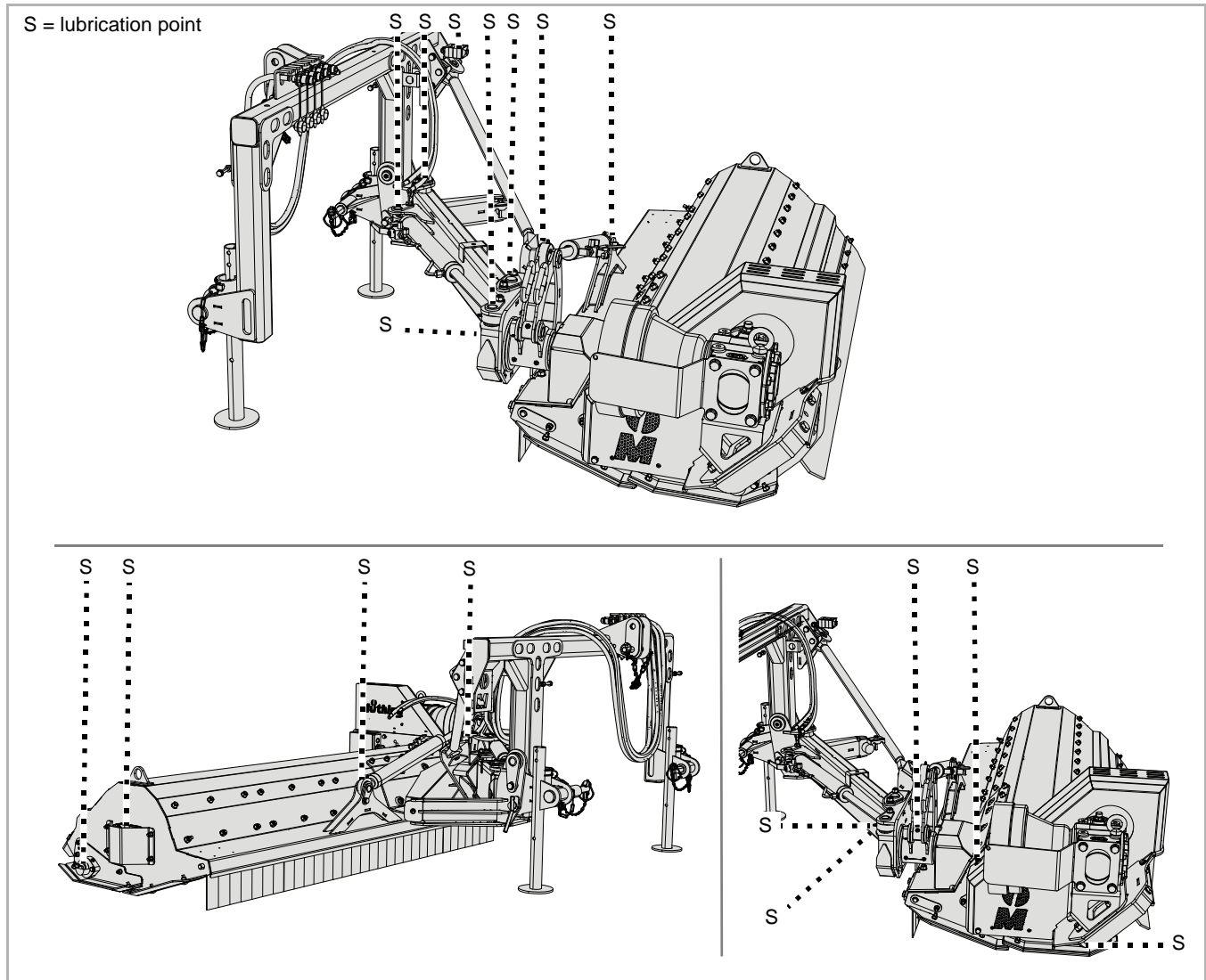

Other lubrication points

The following applies:

- In addition to the lubrication points shown in this operating manual, your machine may have other lubrication points
- As a rule, lubrication points are located at pivots or bearings. Therefore, inspect your entire machine for any such additional lubrication points.



The location of the lubricating nipple is usually shown on one component as an example. If multiple components of this kind exist, the lubricating nipples have to be lubricated at each of these components.

PTO shaft

The PTO shafts are heavily stressed. This means that regular maintenance is decisive for the PTO shafts' service life. Only the most important work is shown here.

Full maintenance work on the PTO shaft:

→ PTO shaft operating manual

Checking

Daily

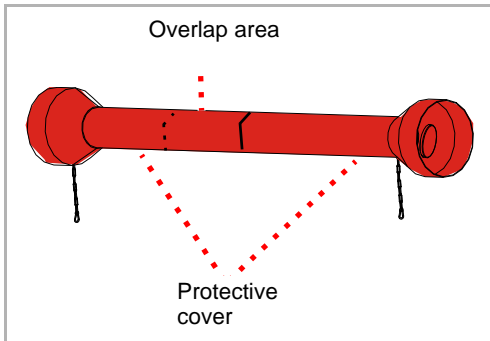

- ▶ Check the PTO shaft for contamination and clean if required. Dust in conjunction with oil and grease results in increased wear

If the PTO shaft is heavily contaminated:

- ▶ Clean PTO shaft
- ▶ Grease the interior of the overlap area of the protective cover

→ PTO shaft operating manual

- ▶ Check protective cover for damage

If the protective cover is damaged:

- ▶ Replace protective cover

→ PTO shaft operating manual

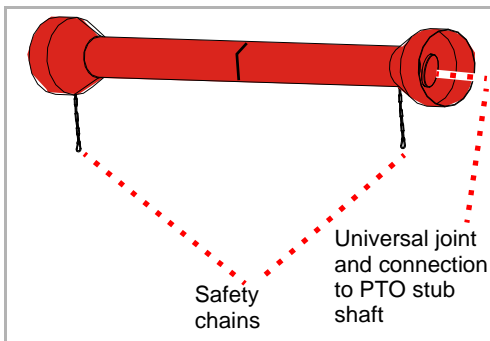

- ▶ Check presence and correct function of safety chains

If the safety chains are not present or are heavily worn:

- ▶ Replace the safety chains

→ PTO shaft operating manual

- ▶ Check the PTO shaft for wear in the universal joints and at the connection to the PTO stub shaft

If the universal joints are heavily worn:

- ▶ Replace the universal joints

→ PTO shaft operating manual

Lubrication

Every 50 hours of operation

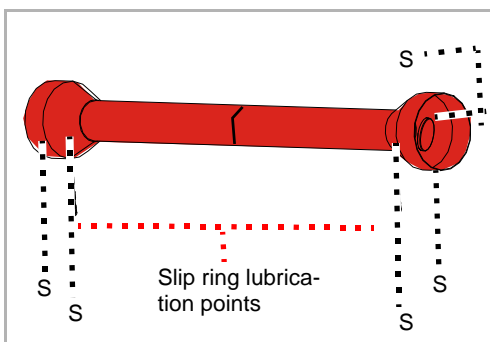

- ▶ Lubricate in the universal joint with 1 - 2 strokes of the grease gun.
- ▶ Lubricate on the slip rings with 1 - 2 pumps of the grease gun

For wide-angle PTO shafts:

The wide-angle joint contains a lubricant reserve which must be filled with 400-500 g [14-17 OZ] of grease.

- ▶ Lubricate with at least 5-6 pumps of the grease gun

→ PTO shaft operating manual

Maintenance

Transmission oil

The gearbox oil must conform to the specification.

→ Chapter »Familiarising yourself with the machine« paragraph »Technical specifications«, page 24

Check

Twice per season

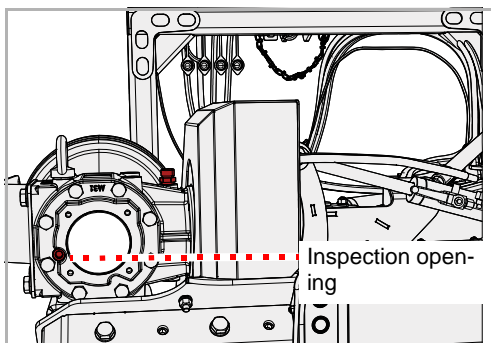

- ▶ Loosen the screw on the inspection opening with an Allen key and remove the screw
- ▶ Check the oil level. The oil level must reach the lower edge of the inspection opening.
- ▶ Retighten the screw at the inspection opening

Refilling

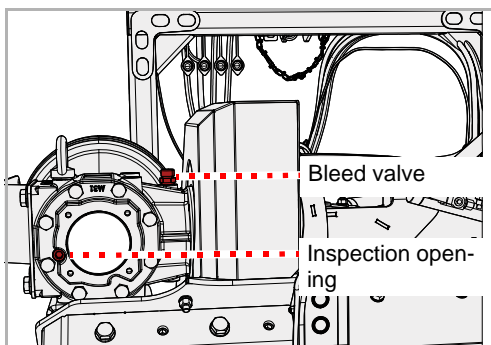

- ▶ Loosen the screw on the inspection opening with an Allen key and remove the screw
- ▶ Unscrew the bleed valve
- ▶ Use a funnel to fill with gear oil of the appropriate specification until the oil level reaches the lower edge of the inspection opening
- ▶ Retighten the screw at the inspection opening
- ▶ Screw the bleed valve back in

Replacement

1x per season

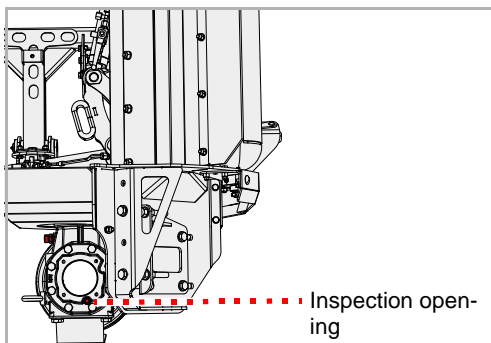
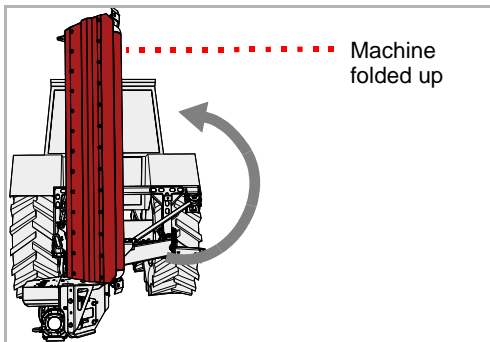

▶ Fold the machine up using the control device on the tractor

▶ Place a collection container under the outlet for the waste oil

▶ Loosen the screw on the inspection opening with an Allen key and remove the screw

▶ Allow the oil to drain out fully

▶ Replace the screw at the inspection opening

▶ Using the tractor's control device, move the machine into its work position

▶ Refill with new gear oil

→ Section »Refilling«

Maintenance

Tools

As required

The tools must be replaced if they:

- Are damaged
- Are heavily worn
- The bore on the tool is worn
- The fastening screws or the fastening nuts are worn

It is important that the rotor runs without unbalance. Therefore:

- Always replace tools with the same type
- Always replace tools opposite each other at the same time
- In case of wear it is best to replace the entire set of tools



Secure the machine

Work can only be carried out on a machine secured against rolling away and dropping. To prevent dropping, for example, permitted and correctly dimensioned support legs can be used.

If the machine is not secured against rolling away and dropping, serious or fatal accidents could result.



New tools – new nuts and bolts

When replacing the tools, the nuts and bolts must also be replaced. *If the nuts and bolts are not replaced, the worn bolts may break. Tools may become detached during work and be flung out. Even persons outside of the hazard area could be seriously injured or killed.*

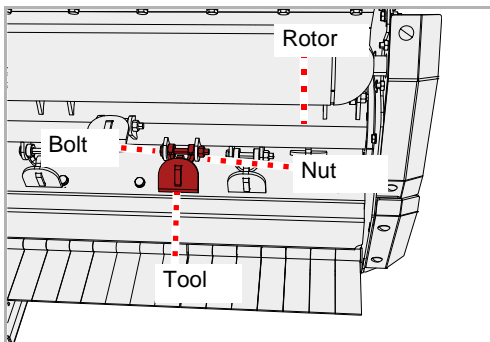

- ▶ Secure the machine against rolling away and dropping
- ▶ Loosen the nuts and remove the bolts
- ▶ Remove old tool
- ▶ Replace new tool in the same manner. If washers were present, insert new washers. Pay attention to the fit of the washers.
- ▶ Fit a new screw and secure with a new nut

V-belt

As required

Checking

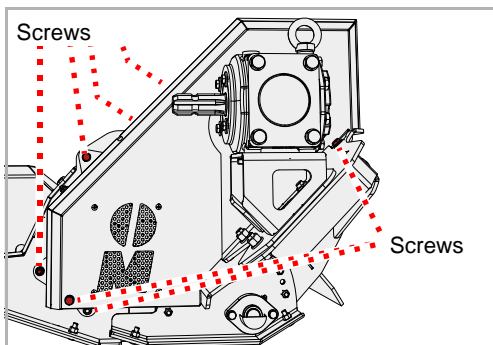
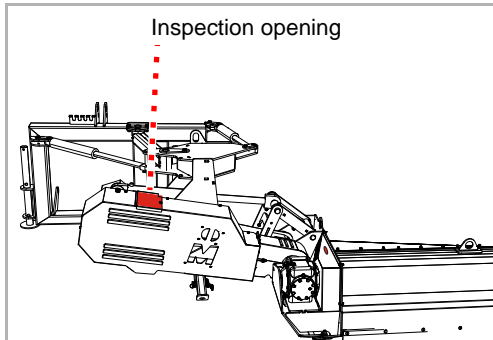

The V-belt is tensioned by a counterweight. If the V-belt is not sufficiently tensioned, it must be retensioned. If there are any tears or the V-belt is damaged, it must be replaced.

There is an inspection opening on the machine.

- ▶ Check the tension of the V-belt. When under a load of 6 kg, it must not be possible to push the V-belt through more than 10 mm.

- ▶ Remove the screws, remove the safety cover.
- ▶ Check the V-belt for damage
- ▶ Reassemble the safety cover

Maintenance

Tensioning

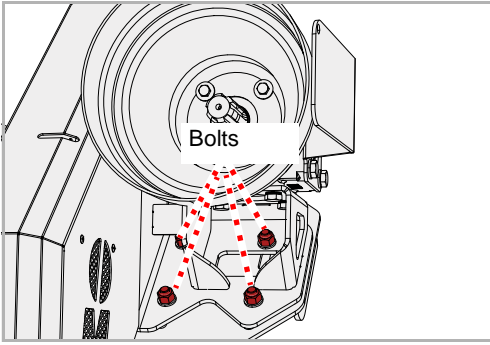

- ▶ Loosen the nuts but do not remove them.

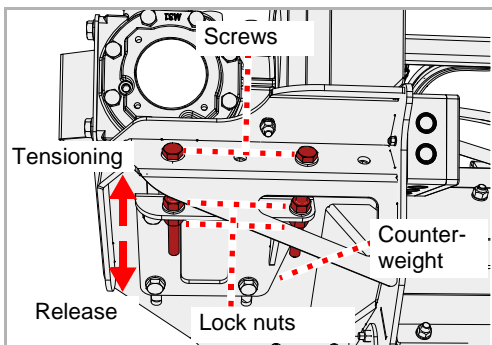

- ▶ Loosen the lock nuts.
- ▶ Use the screws to set the drive belt tension as required via the counterweight
- ▶ Retighten the lock nuts

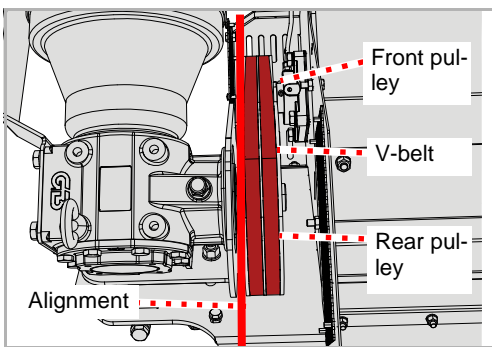

- ▶ Check the alignment of the pulleys. The rear pulley must be in line with the front pulley.

If the pulleys are not in line:

- ▶ Only loosen the lock nut on one screw on the counterweight and align the rear pulley with the front pulley
- ▶ Check the V-belt tension

Replacement

If there are any tears or other damage on the V-belt, it must be replaced.

- ▶ Remove the screws, remove the safety cover.

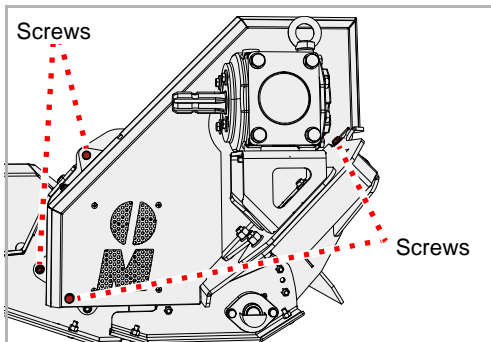

The V-belt unit consists of two narrow V-belts.

- ▶ Loosen the nuts but do not remove them.

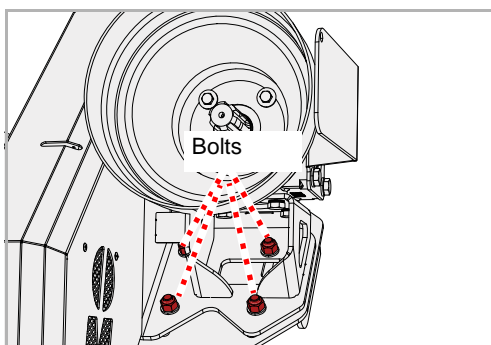

- ▶ Loosen the lock nuts.
- ▶ Slacken the drive belts using the screws

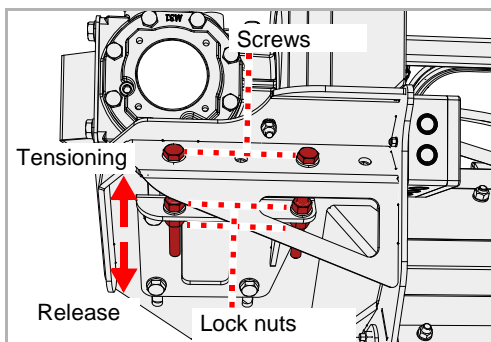

- ▶ Remove the old V-belts.
 - ▶ Fit the new V-belts
 - ▶ Check the V-belt for correct positioning
 - ▶ Tension the V-belt
- Section »Tensioning«, Page 60
- ▶ Reassemble the safety cover

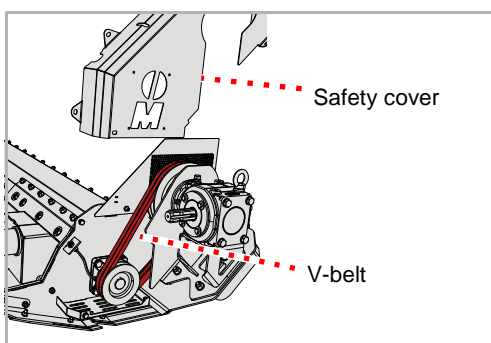

Maintenance

Runners

As required

The runners protect the machine from direct contact with the ground. If they are not replaced in good time, the housing of the machine will be damaged.



Secure the machine

Work can only be carried out on a machine secured against rolling away and dropping. To prevent dropping, for example, permitted and correctly dimensioned support legs can be used.

If the machine is not secured against rolling away and lowering, serious or fatal accidents could result.

Runners

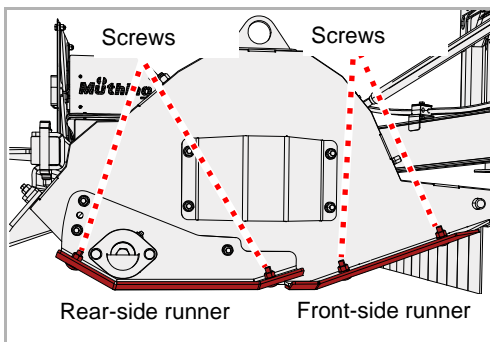

There are runners at the front and runners at the back on each side.

- ▶ Undo nuts, remove screws and washers.
- ▶ Remove old runner
- ▶ Fit new runner
- ▶ Fit new screws and washers
- ▶ Secure screws with new nuts

If the runners also need to be replaced on the opposite side:

- ▶ Replace the runners on the opposite side as well.

Warning signs with lighting device

For transporting the machine on the road, warning signs with integrated lighting equipment are available.

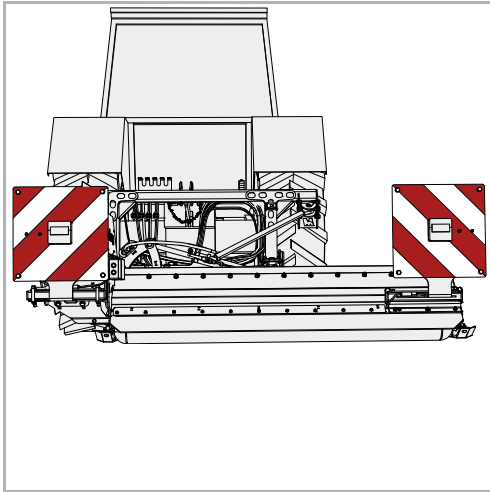

Wear insert

A metal insert protects the housing from wear.

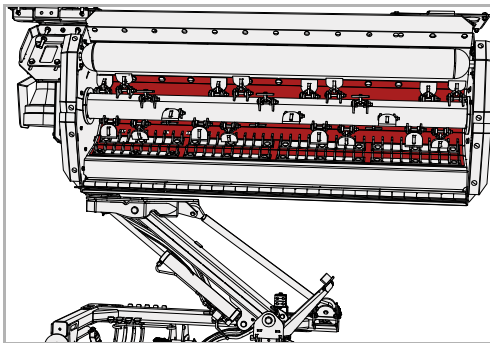

short chopping bar

The short chopping bar optimises the material feed. This produces better cutting.

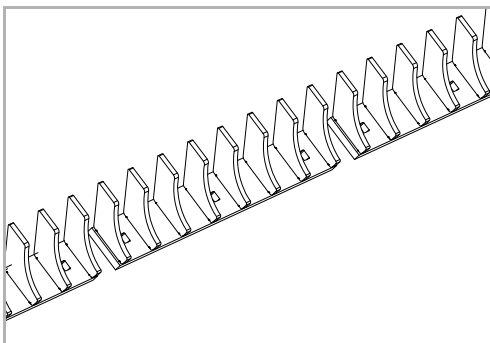

Accessory

Operating hours counter

An electronic operating hours counter displays the actual operating duration. This means that data can be recorded precisely and used, for example, for calculations.

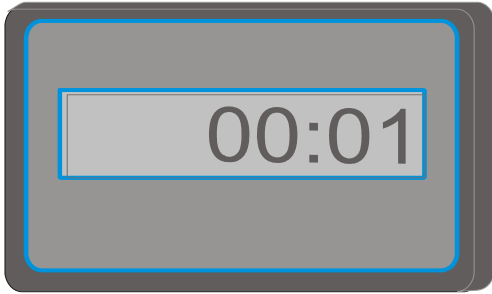

Fault elimination

Faults can often be eliminated quickly and easily. In the event of hydraulic problems, first check:

- Are the hydraulic hoses properly connected?
- Is the control valve at the tractor defect?
If so, contact your dealer.
- Is the hydraulic pump of the tractor defective?
If so, contact your dealer.

Before calling Customer Service, refer to the table below to check whether the fault is one you can eliminate yourself.

Fault	Cause	Remedy
Strong vibrations and high noise development	Tools are worn	Replace the tools
	One or more tools are missing	Replace tools
	Tools are damaged	Replace the tools
	Bearings for the rotor are worn	Have the bearings replaced
	Foreign bodies, such as wire, are wound around the rotor	Remove foreign bodies
	Tools have become loose	Tighten nuts on screws
	Speed of rotation of the PTO stub shaft is not set correctly	Set the correct speed of rotation on the PTO stub shaft
	Rotor not correctly counterbalanced	Check balancing and rebalance the rotor if necessary
Tools wearing quickly	The tools are working too deeply	Set correct working depth
Material cut too rough and cut material not distributed evenly	Drive speed too high	Reduce the drive speed
	The tools are working too deeply	Set correct working depth
	The tools are working too high	Set correct working depth
	V-belt worn	Replace V-belt set
	V-belt not correctly tensioned	Check V-belt tension and retension if necessary
	Speed of rotation of the tractor PTO stub shaft is too low	Increase the rpm
	Tools are worn	Replace the tools
	The machine is not standing parallel to the ground	Adjust the machine correctly
Rotor does not turn	Rotor is blocked by a foreign body	Remove foreign bodies
	The PTO shaft is free-wheeling or the gear box is incorrectly assembled.	Have the free running state correctly assembled

Fault elimination

Fault	Cause	Remedy
PTO shaft rotating, rotor is not	V-belt torn	Replace the V-belt
Unusual noises from the PTO shaft	Insufficient lubrication	Lubricate the PTO shaft
Gear box overheating	Incorrect oil specification	Change oil and select oil with correct specification
	Oil too old	Change oil
	Oil level too low	Fill the oil to the lower edge of the inspection opening
	Machine overload	Maintain rpm in correct region, adjust driving speed to suit the work, maintain performance area (avoid excessively heavy growth or excessively thick branches)
High wear on V-belts V-belts running hot Power transmission not optimal	The tools are working too deeply and touching the ground	Set correct working depth
	Pulleys not aligned in parallel	Have pulleys correctly aligned
	V-belt is worn	Replace the V-belt
	V-belt is not correctly tensioned	Check the tension jack
Loss of oil at gear box or at centre bearing	Sealing rings worn or damaged	Have sealing rings replaced
Drive elements broken	Machine was started up abruptly or is blocked by foreign bodies	Have defective drive element replaced. Start the machine up slowly.

Disposal of the machine

When the service life of your machine is over, it must be disposed of properly. Please observe currently valid disposal regulations.

Metal parts

All metal machine components can be sent for metal recycling.

Plastic parts

All plastic parts are marked and can be recycled.

Oil

Collect fluid from the hydraulic system in a suitable container and dispose of at a used oil collection facility.

EU-conformity declaration

EC Directive
2006/42/EG

Müthing GmbH & Co. KG Soest
Am Silberg 23
D-59494 Soest

assumes sole responsibility for declaring that the following product
complies with EC Directive 2006/42/EC:

MU-FM/S and additional equipment

Assorted samples of harmonized standards:

- DIN EN ISO 4254-1
- DIN EN ISO 4254-12
- EN 13524

Soest, 28.10.2022

Andreas Rohde
CEO and authorised person for compiling technical documentation

Copy of the type plate/serial number entry

Machine type: Flail mower

Maschine Name:

Working width:

Serial number:

Year of construction:

UK Declaration of Conformity

UKCA

Müthing GmbH & Co. KG Soest
Am Silberg 23
D-59494 Soest
Germany

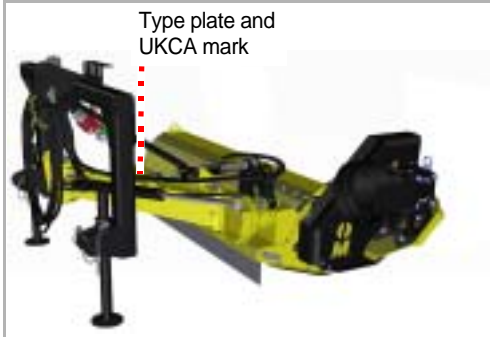

declares under sole responsibility that the machine conforms with the following directives:

- Supply of Machinery (Safety) Regulations 2008

Assorted samples of harmonized standards:

- BS EN ISO 4254-1
- BS EN ISO 4254-12
- BS EN 13524

Machine designation	MU-FM/S and additional equipment
---------------------	----------------------------------

The special technical documents corresponding to the machine have been created according to Annex VII, Part B.

Soest, 28.10.2022

Andreas Rohde
CEO and authorised person for compiling technical documentation

Copy of the type plate/serial number entry

Type of machine: Mulcher

Model:

Working Width:

Machine ID:

Production Year:

Index

A			
Accessory	63		
Operating hours counter	64		
short chopping bar	63		
Warning signs with lighting device	63		
Wear insert	63		
assembly	23		
C			
Care	42		
Centre of gravity	15		
Cleaning	42		
Connecting			
Electrics	30		
Hydraulics	30		
Coupling	27		
D			
Direction information	13		
E			
Electrics			
Connecting	30		
Employer	8		
F			
Fault	65		
Features	22		
H			
Hydraulics			
Connecting	30		
I			
Instruction	8		
L			
labels, see warning signs			
Lubricate bearings	53		
M			
Machine			
Storing	47		
Maintenance			
General information	49		
Maintenance intervals	52		
Overview of lubrication points	54		
Safety	48		
P			
Parking	43		
Pictograms	9		
Protective procedure			
Oils or lubricants	49		
R			
Range of application	21		
Carbide M shackle flails	21		
S			
Safety	10		
Agricultural training	13		
Altered driving and braking behaviour	17		
Care and maintenance intervals	19		
Care and maintenance work	19		
Centre of gravity	15		
Check the screwed connections	20		
Cleaning	20		
Coupling	14		
Proper use	21		
Putting the machine into operation	17		
Riding on the machine	17		
Total weight	15		
Uncoupling the machine	19		
Warning signs	10		
Welding work	20		
Scope of delivery	26		
Screwed connections	51		
Setting down the machine in a secure position	43		
Symbols	9		
T			
Target group	8		
Task	39		
Technical specifications	24		
Tightening torques			
General	51		
Transport without coupling	35		
W			
Warning signs	10, 34		
Meaning	11		
Work position	36		
Working width	31		

