



ERSATZTEILLISTE | Spare parts list

Liste des pièces de rechange | Lista de repuestos

MU-C-F-HY 120 - 160

AB SERIE | as of series | á partir de série | desde de la serie 2015

AUSGABE | edition | version | edición 12.2019

ARTIKELNUMMER | article number | numéro d'article | número de artículo MU-C-F-HY_ET_15_2019-12

Übertragen Sie hier bitte die Daten Ihres Gerätes und des verwendeten Getriebes.

Enter the details for your implement and the gear box you are using here.

Veuillez inscrire ici les références de votre machine et celles du boîtier.

Introduzca aquí los datos de su equipo y la transmisión utilizada.



*Beispiel Typenschild | Type plate example
Exemple de plaque signalétique | Ejemplo de una placa de características*

Benennung Designation Désignation Designación	Eintrag Entry N° d'enregistrement Registro
Modell Model Modèle Modelo	MU-C F HY 120 - 160 <input type="checkbox"/> 120 <input type="checkbox"/> 140 <input type="checkbox"/> 160
Seriennummer Serial number N° de série Número de serie	
Baujahr Year of manufacture Année de construction Año de construcción	
Getriebetyp Gearbox type Type de Système d'entraînement Tipo de transmisión	
Anbaubock Headstock Attelage Soporte adosado	
Händler Dealer Distributeur Concesionario	
Inbetriebnahme am Commissioning date Date de mise en service Fecha de puesta en servicio	

Bei bitte deutlich ankreuzen !

Where there are checkboxes , please check these clearly!

Veuillez cocher les cases lisiblement!

Por favor, marque con una cruz en la casilla .



20 horizontal dotted lines for writing.



Einleitung Introduction Introduction Introducción	6
Gerätebeschreibung Device description Description de l'appareil Description del dispositivo 	7
Grundausführung Basic model Modèle de base Modelo básico 	
Gehäuse Housing Caisson Caja 	8
Hydro - Antrieb Hydraulic drive Entraînement hydraulique Accionamiento hidráulico 	12
Hydro Antrieb Übersetzung Hydraulic drive transmission ratio Entraînement hydraulique transmission Accionamiento hidráulico multiplicación 	16
Schäkelrotor Shackle rotor Rotor á manillas Grillete rotor 	18
Stützwalze Support roller Rouleau d'appui Cilindro de apoyo 	22
Dreipunktbock 3-point trestle Support d'attelage trois point Soporte de tres apoyos 	26
Sonderzubehör Optional accessory Accessoires optionnels Componentes especiales 	
Stützrad Support wheel Roue d'appui Rueda de soporte 	30
Unterlenkeraufnahme Lower link receiver Logement du bras inférieur Alojamiento del brazo inferior 	34
Gerätedreieck KAT 0 Implement triangle KAT 0 Triangle d'attelage KAT 0 Triángulo del dispositivo KAT 0 	36
Adaption IBEX Adaptation IBEX Adaptation IBEX Adaptación IBEX 	38
Adaption HAKO CM600 Adaptation HAKO CM600 Adaptation HAKO CM600 Adaptación HAKO CM600 	42
Kurzhäckselleiste Short chopping bar Lame hache-paille courte Listón de corte de paja corto 	44
Verschleißeinlage Wear insert Blindage Junta de desgaste 	46
Hydraulische Druckentlastung MU-SOFA Hydraulic pressure relief MU-SOFA Délestage hydraulique MU-SOFA Descarga de presión hidráulica MU-SOFA 	48
Kontakte Contacts Contacts Contactos 	
National Nactional National Nacional 	53
International Internactional Internationale Internacionalmente 	54

20 horizontal dotted lines for writing.



SEHR GEEHRTER KUNDE,

auf den folgenden Seiten finden Sie eine vollständige Übersicht aller Bauteile Ihres Müthing Mulchgerätes MU-C F HY 120 - 160. Anhand dieser Unterlage bitten wir Sie benötigte Ersatzteile genau zu identifizieren und mit den nachfolgenden Angaben zu bestellen. Benötigen Sie Hilfe oder weitere Informationen kontaktieren Sie uns.

Vielen Dank - Ihr Müthing-Team

CHER CLIENT,

Vous trouverez sur les pages suivantes une description complète des composants de votre broyeur Müthing MU-C F HY 120 - 160. Nous vous invitons à identifier exactement les pièces de rechange requises à l'appui de ce document et de les commander en indiquant le n° de référence de pièces de rechange. N'hésitez pas à nous contacter si vous avez besoin d'aide ou d'informations complémentaires.

Merci beaucoup – Votre équipe Müthing

DEAR CUSTOMER,

The following pages offer a complete overview of the components in your Müthing MU-C F HY 120 - 160 mulcher. We are providing you with this document so that you can identify exactly the spare parts you require and order them using the spare part numbers listed. Should you need any assistance or further information, please contact us.

Kind regards - Your Müthing team

ESTIMADO CLIENTE,

En las siguientes páginas ponemos a su disposición una relación completa de los componentes de su trituradora MU-C F HY 120 - 160 de Müthing. Le rogamos que con ayuda de este listado identifique las piezas de repuesto necesarias y las encargue con su correspondiente número de repuesto. No dude en ponerse en contacto con nosotros para solicitar ayuda o información ampliada.

Muchas gracias - Su equipo Müthing



Beachten Sie immer die Sicherheitshinweise der Betriebsanleitung !

Always follow the safety instructions in the operating manual.

Veuillez toujours tenir compte des consignes de sécurité figurant dans le manuel d'utilisation !

Observe siempre las indicaciones de seguridad de las instrucciones de servicio !

DIE HAUPTBAUGRUPPEN SIND:

1. Mulchergehäuse mit Schutzlamellen, hinterem Gummischutz und Gleitkufen
2. Dreipunktanbaubock
3. Rotor mit Lagerung, Werkzeugen und Werkzeughaltern
4. Stützwalze (Stützräder) mit Lagerung
5. Hydro Antrieb mit Keilriemenschutzhaube
6. Sonderzubehör

THE MAIN COMPONENTS ARE:

1. Mulcher housing with protective strips, rear rubber protector and skids
2. Three-point headstock
3. Rotor with mount, tools and tool holders
4. Support roller (support wheels) with mount
5. Hydraulic drive with V-belt guard
6. Optional accessories



LES GROUPES PRINCIPAUX SONT:

1. Carter du broyeur avec lamelles de protection, protection en caoutchouc à l'arrière et patins de glissement
2. Attelage trois points
3. Rotor équilibré avec outils et supports d'outils
4. Rouleau-support (roues supports) avec suspension
5. Entraînement hydraulique avec capot de protection
6. Accessoires spécifiques

LOS GRUPOS CONSTRUCTIVOS PRINCIPALES SON:

1. Carcasa de la trituradora con placas de protección, protección trasera de goma y patines
2. Enganche de tres puntos
3. Rotor con cojinete, herramientas y portaherramientas
4. Cilindro de apoyo (ruedas de apoyo) con cojinete
5. Accionamiento hidráulico con cubierta protectora de la correa
6. Accesorio especial

| Hauptbaugruppe Schlegelmulcher Baureihe MU-C F HY 120 - 160

| Main assembly of the MU-C F HY 120 - 160 flail mulcher

| Groupe principal Broyeur à marteaux série MU-C F HY 120 - 160

| Grupo constructivo desbrozadora serie MU-C F HY 120 - 160

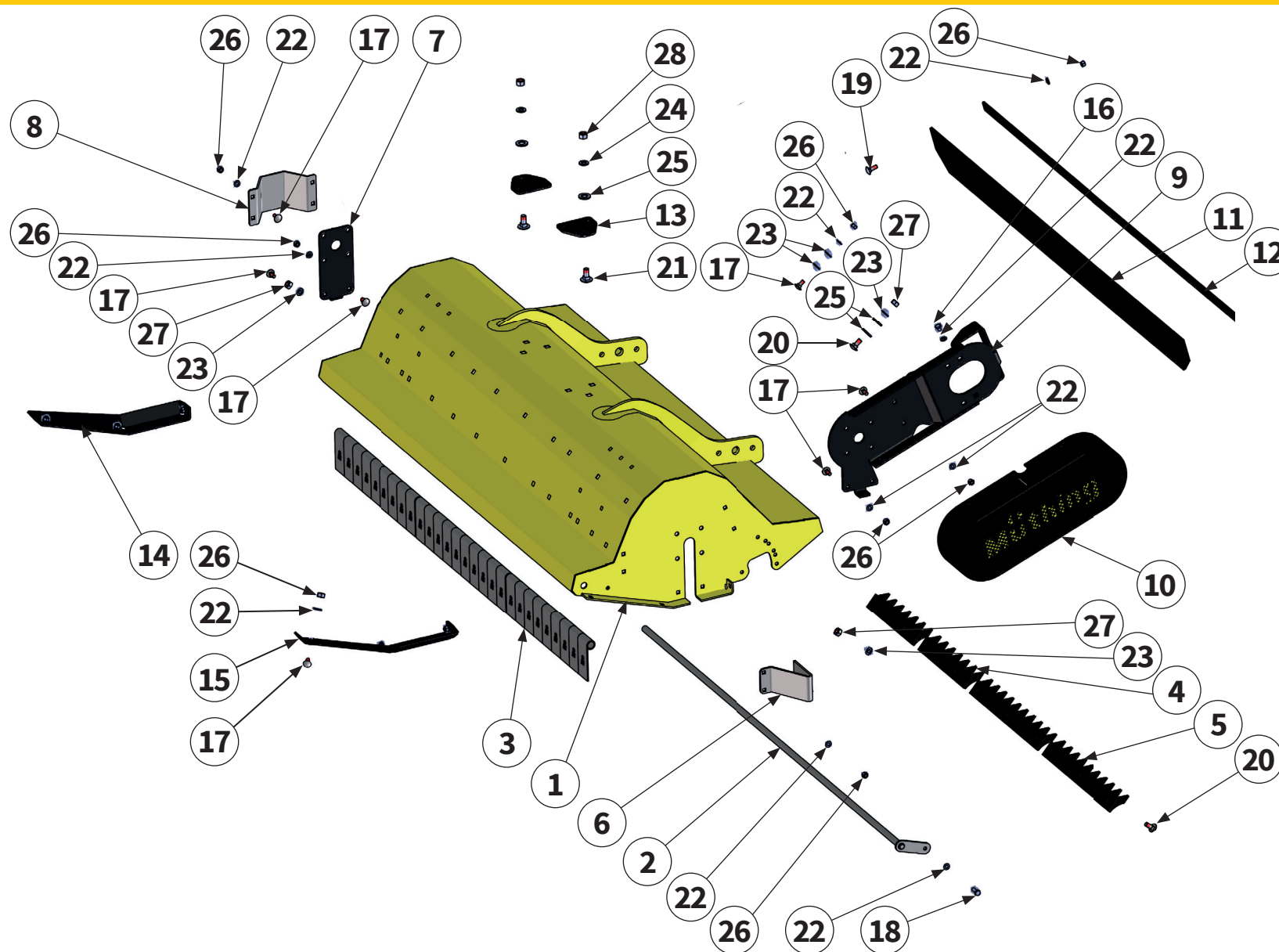

Pos.-Nr. No. Número	Ersatzteilnummer Manufacturer part number Numéro de pièce du fabricant Número de pieza del fabricante			DE Bezeichnung	EN Designation	FR Désignation	ES Designación
	Anzahl quantity quantité número						
	MU-C 120	MU-C 140	MU-C 160				
1	00015351 1	00015639 1	00015642 1	Gehäuse	housing	Caisson	Caja
2	00001124 1	00001374 1	00001798 1	Pendelwelle	swing shaft	Arbre oscillant	Eje del péndulo
3	24	MU0501131 28	32	Pendelklappen	flap with swing protection	Volvet de protection	Tapa protectora del péndulo
4	-	00005472 2	-	Gegenschneide 300	chopping bars	Lame hache-paille courte	Listón de corte de paja corto
5	3	00005474 2	4	Gegenschneide 400	chopping bars	Lame hache-paille courte	Listón de corte de paja corto
6	1	MU0216011 1	1	Abweiser	deflector	Déflecteur	Deflector
7	1	MU0501171 1	1	Verschlußblech	sealing sheet	Tôle de fermeture	Chapa de cierre
8	1	00001129 1	1	Lagerabdeckung	bearing cover	Couvercle de palier	Tapa de cojinete
9	1	00014748 1	1	Halteblech	retaining plate	Tôle de maintien	Chapa soporte
10	1	MU0510051 1	1	Schutzabdeckung	protective cover	Recouvrement de protection	Cubierta protectora
11	00003530 1	00003524 1	00003519 1	Schutzgummi	guard	Protection	Protección
12	00003529 1	00003523 1	00003518 1	Klemmleiste	support plate	Tôle de support	Chapa de retención
13	2	00004053 2	2	Distanzblech	spacer plate	Tôle d'écartement	Chapa distanciadora
14	1	00010882 1	1	Verschleißkufen links	wear runner left	Patin d'usure gauche	Cuchilla de desgaste izquierda

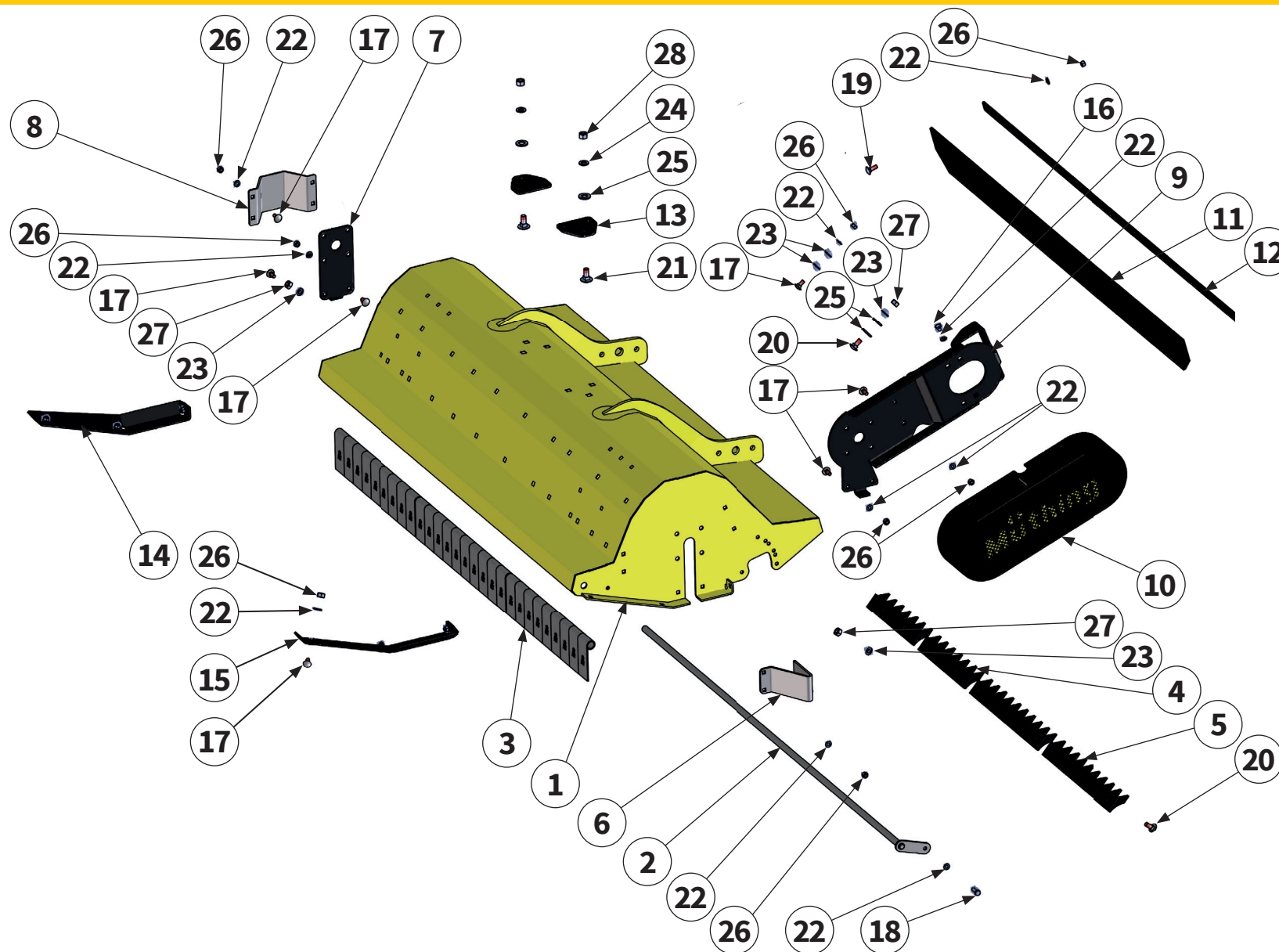

28Pos.- Nr. No. Número Número	Ersatzteilnummer Manufacturer part number Numéro de pièce du fabricant Número de pieza del fabricante			DE Bezeichnung	EN Designation	FR Désignation	ES Designación
	Anzahl quantity quantité número						
	MU-C 120	MU-C 140	MU-C 160				
15	1	00010883 1	1	Verschleißkufen rechts	wear runner right	Patin d'usure droite	Cuchilla de desgaste derecha
16	4	MU980127 4	4	Schraube	bolt	Vis	Tornillo
17	21	MU980107 21	21	Schraube	bolt	Vis	Tornillo
18	1	MU980109 1	1	Schraube	bolt	Vis	Tornillo
19	9	MU0099988 11	13	Schraube	bolt	Vis	Tornillo
20	11	00000903 12	14	Schraube	bolt	Vis	Tornillo
21	6	MU980310 6	6	Schraube	bolt	Vis	Tornillo
22	36	MU0099999 38	42	Scheibe	washer	Disque	Arandela
23	17	MU980202 18	20	Scheibe	washer	Disque	Arandela
24	6	MU980302 6	6	Scheibe	washer	Disque	Arandela
25	10	MU980402 10	10	Scheibe	washer	Disque	Arandela
26	31	MU0099961 33	35	Mutter	nut	Écrou	Tuerca
27	11	MU0099960 12	14	Mutter	nut	Écrou	Tuerca
28	6	MU980301 6	6	Mutter	nut	Écrou	Tuerca

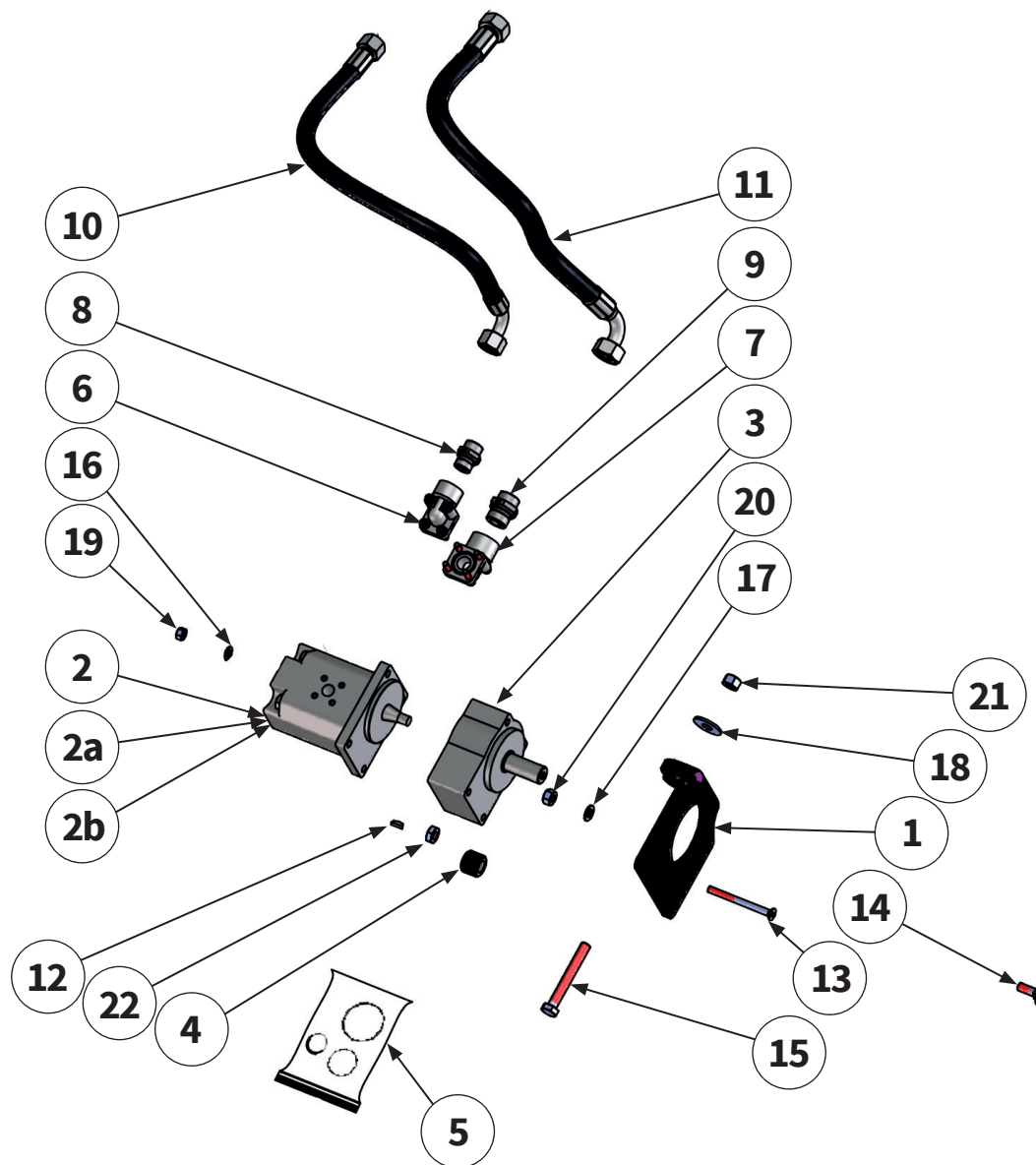

Pos.-Nr. No. Numéro Número	Ersatzteilnummer Manufacturer part number Numéro de pièce du fabricant Número de pieza del fabricante			DE Bezeichnung	EN Designation	FR Désignation	ES Designación
	Anzahl quantity quantité número						
	MU-C 120	MU-C 140	MU-C 160				
1	1	00014772	1	Spannblech	clamping plate	Plaque de serrage	Chapa de sujeción
2	1	00015679	1	Zahnradmotor	hydraulic motor	Moteur hydraulique	Motor hidráulico
		Volumina volume volume el volumen = 17 ccm/U					
2a	1	00015680	1	Zahnradmotor	hydraulic motor	Moteur hydraulique	Motor hidráulico
		Volumina volume volume el volumen = 20 ccm/U					
2b	1	00017440	1	Zahnradmotor	hydraulic motor	Moteur hydraulique	Motor hidráulico
		Volumina volume volume el volumen = 26 ccm/U					
3	1	00015678	1	Vorsatzlager	attachment bearing	Palier avant	Cojinete antepuesto
4	1	00008099	1	Zahnrad	gearwheel	Roue dentée	Rueda dentada
5	1	MUDM0004	1	Dichtsatz	sealpacket	Kit d'étanchéité	Juego de estanqueización
6	1	00015682	1	Flansch Vorlauf	flange supply	Bride avance	Brida línea de alimentación
7	1	00015684	1	Flansch Rücklauf	flange return	Bride retour	Brida línea de retorno
8	1	00015668	1	Verschraubung	Screwed connection	Raccord à vis	Atornillamiento
9	1	00015669	1	Verschraubung	Screwed connection	Raccord à vis	Atornillamiento



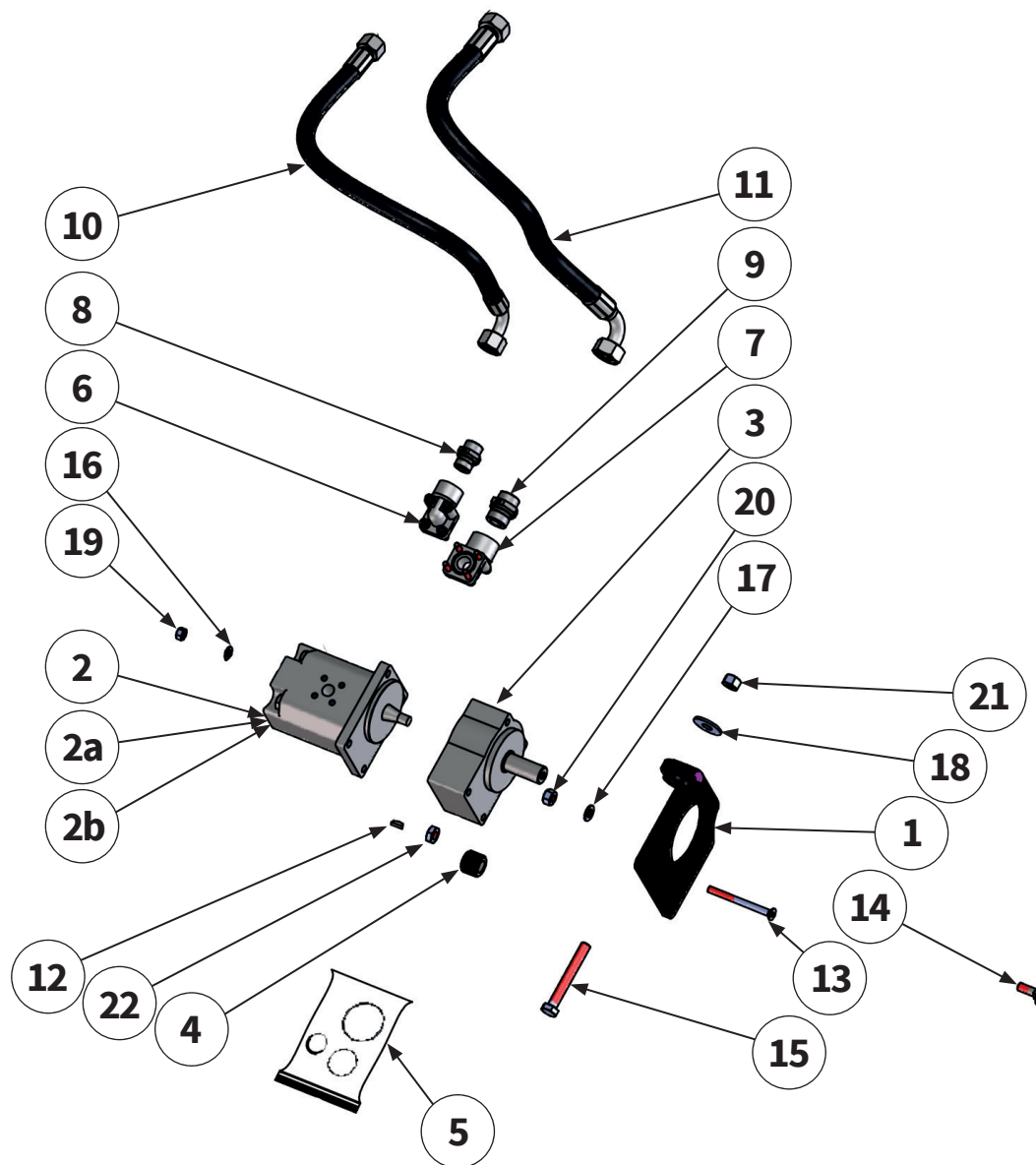

Pos.-Nr. No. Número	Ersatzteilnummer Manufacturer part number Numéro de pièce du fabricant Número de pieza del fabricante			DE Bezeichnung	EN Designation	FR Désignation	ES Designación
	Anzahl quantity quantité número						
	MU-C 120	MU-C 140	MU-C 160				
10	1	00015672 1	1	Hydraulikschlauch	hydraulic hose	Tuyau hydraulique	Tubo flexible hidráulico
11	1	00015677 1	1	Hydraulikschlauch	hydraulic hose	Tuyau hydraulique	Tubo flexible hidráulico
12	1	MU982833 1	1	Scheibenfeder	woodruff key	Clavette-disque	Muelle de disco
13	4	00008123 4	4	Schraube	bolt	Vis	Tornillo
14	4	00000904 4	4	Schraube	bolt	Vis	Tornillo
15	1	MU980316 1	1	Schraube	bolt	Vis	Tornillo
16	4	MU0099999 4	4	Scheibe	washer	Disque	Arandela
17	4	MU980202 4	4	Scheibe	washer	Disque	Arandela
18	1	MU980203 1	1	Scheibe	washer	Disque	Arandela
19	4	MU0099961 4	4	Mutter	nut	Écrou	Tuerca
20	4	MU0099960 4	4	Mutter	nut	Écrou	Tuerca
21	1	MU980301 1	1	Mutter	nut	Écrou	Tuerca
22	1	MU982832 1	1	Mutter	nut	Écrou	Tuerca



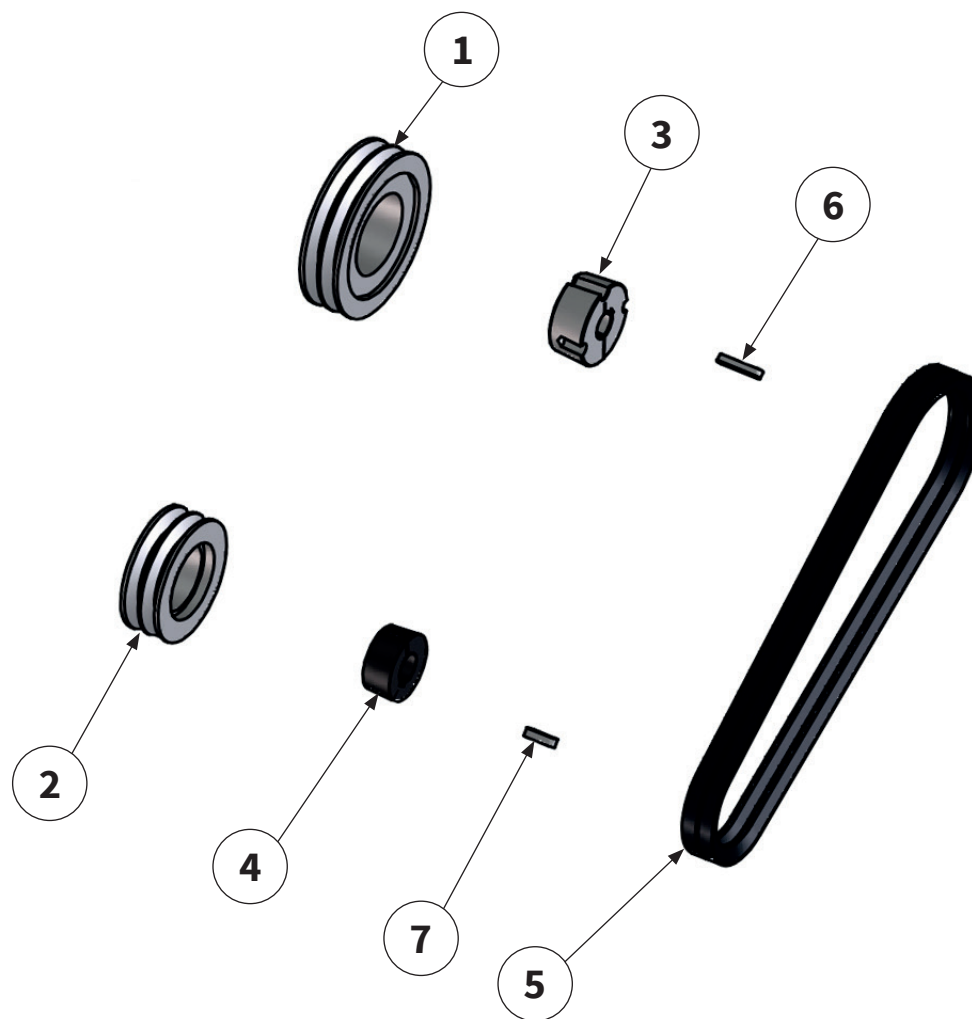

Pos.-Nr. No. Número	Ersatzteilnummer Manufacturer part number Numéro de pièce du fabricant Número de pieza del fabricante						DE Bezeichnung	EN Designation	FR Désignation	ES Designación
	Volumenstrom Fahrzeug Vehicle volume flow rate Débit volumique véhicule Caudal vehículo									
	35 l/min	40 l/min	45 l/min	50 l/min	55 l/min	60 l/min				
1	MU0501111			MU982903	MU0501111	00034455	Keilriemenscheibe	belt pulley	Poulie	Polea
	1	1	1	1	1	1				
2	00001087						Keilriemenscheibe	belt pulley	Poulie	Polea
	1	1	1	1	1	1				
3	00008140						Taperbuchse	clamping bush	Douille de serrage	Manguito de sujeción
	1	1	1	1	1	1				
4	MU981805						Taperbuchse	clamping bush	Douille de serrage	Manguito de sujeción
	1	1	1	1	1	1				
5	MU0501995			MU981822	MU0501995		Keilriemen	V-belt	Courroie trapézoïdale	Correa trapezoidal
	2	2	2	2	2	2				
6	00008108						Paßfeder	parallel key	Clavette	Chaveta de ajuste
	1	1	1	1	1	1				
7	00001085						Paßfeder	parallel key	Clavette	Chaveta de ajuste
	1	1	1	1	1	1				



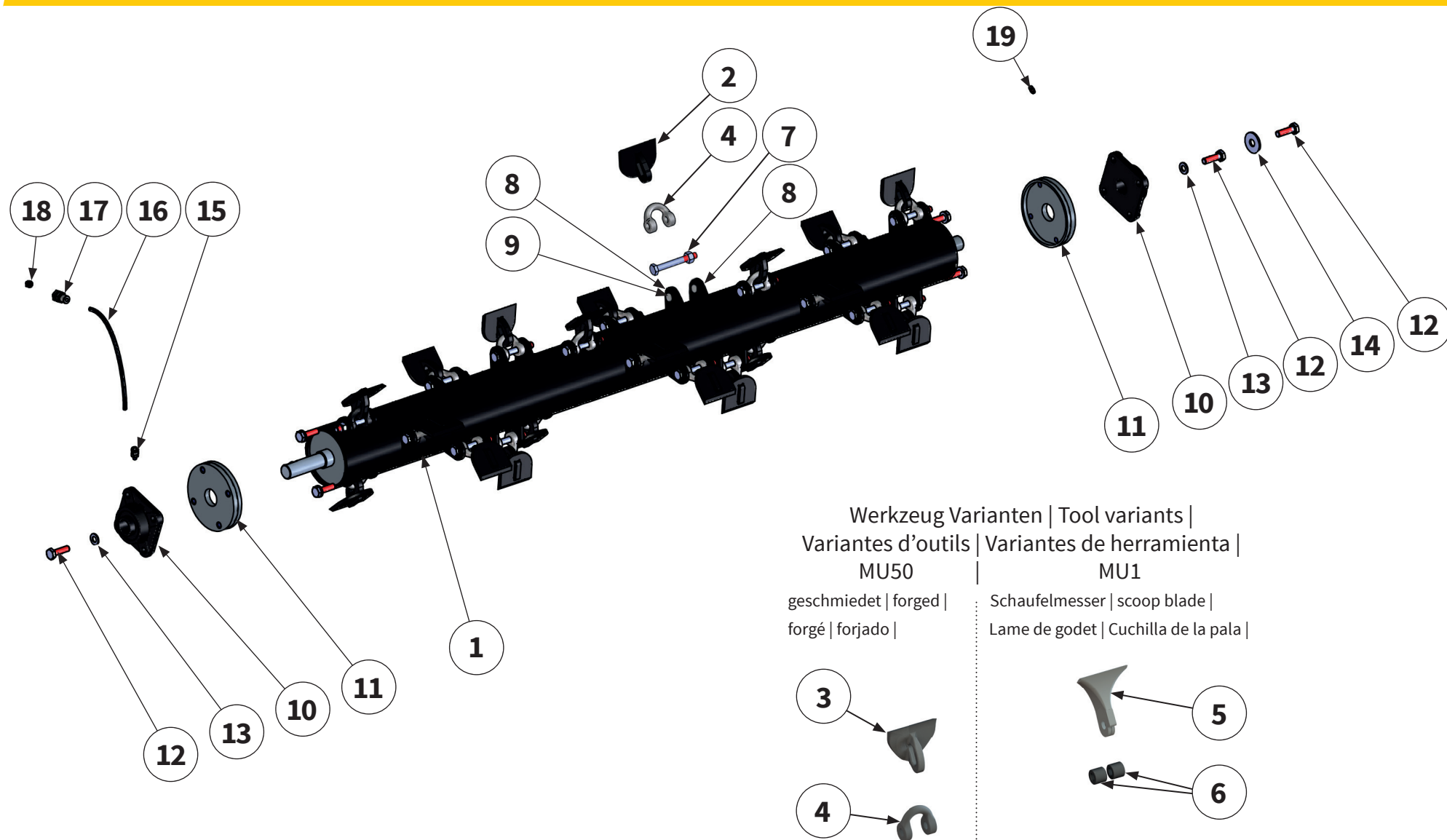

Werkzeug Varianten | Tool variants |
 Variantes d'outils | Variantes de herramienta |

MU50
 geschmiedet | forged |
 forgé | forjado |

MU1
 Schaufelmesser | scoop blade |
 Lame de godet | Cuchilla de la pala |

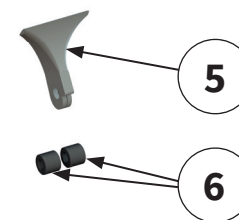
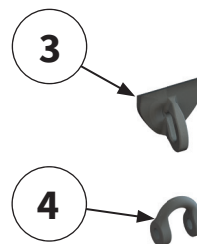

Pos.-Nr. No. Numéro Número	Ersatzteilnummer Manufacturer part number Numéro de pièce du fabricant Número de pieza del fabricante			DE Bezeichnung	EN Designation	FR Désignation	ES Designación
	Anzahl quantity quantité número						
	MU-C 120	MU-C 140	MU-C 160				
1	MU5040031	MU5040041	00010955	Rotor inkl. Werkzeug	rotor with tools	Rotor avec outils	Rotor con herram
2	20	MU5 24	28	Schäkelmesser	shackle flail	Lame de manille	Chuchilla del grillete
3	20	MU50 24	28	Schäkelmesser	shackle flail	Lame de manille	Chuchilla del grillete
4	20	MU0801031 24	28	Schäkel	shackle	Manille	Grillete
5	20	MU1 24	28	Schaufelmesser	scoop blade	Lame de godet	Cuchilla de la pala
6	40	MU3 48	56	Buchse	bush	Douille	Casquillo
7	20	MU0801041 24	28	Schraube mit Mutter	bolt with nut	Vis avec Écrou	Tornillo con Tuerca
8	40	MU0504101 48	56	Werkzeughalter	tool holders	Porte-outils	portaherramientas
9	20	MU0702051 24	28	Verdrehsicherung	anti-twist protection	Sécurité anti-torsion	Seguro contra giro
10	2	MU0501041 2	2	Rotorlager	rotor holder	Support de Rotor	Soporte del Rotor
11	2	MU5102211 2	2	Wickelschutz	anti-wrapping device	Protection contre l'enroulement	Protección enrollable
12	9	MU980222 9	9	Schraube	bolt	Vis	Tornillo
13	8	MU980202 8	8	Scheibe	washer	Disque	Arandela

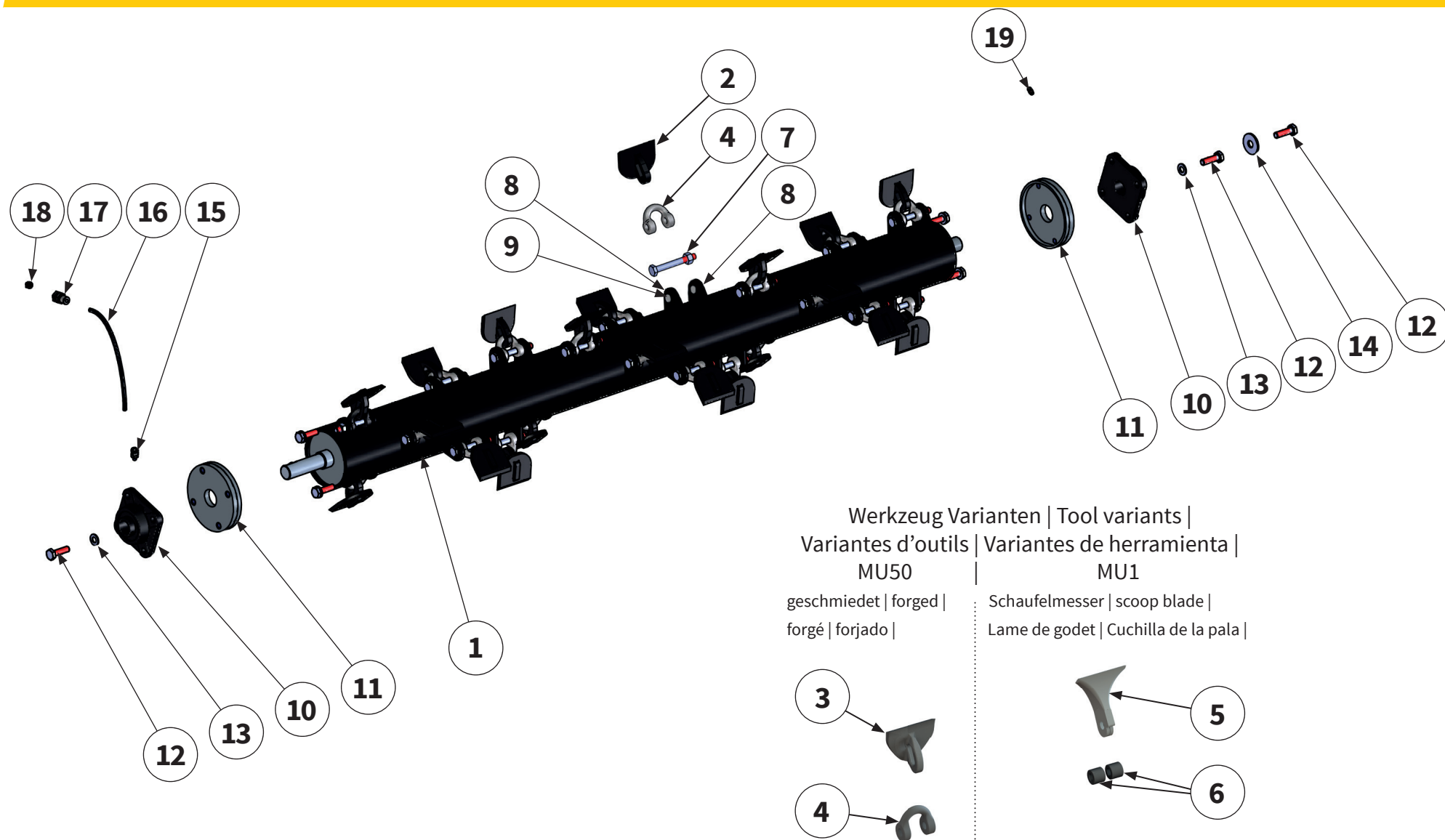

Werkzeug Varianten | Tool variants |
 Variantes d'outils | Variantes de herramienta |

MU50
 geschmiedet | forged |
 forgé | forjado |

MU1
 Schaufelmesser | scoop blade |
 Lame de godet | Cuchilla de la pala |

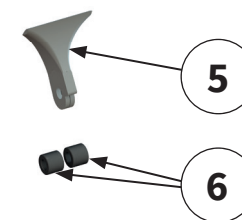
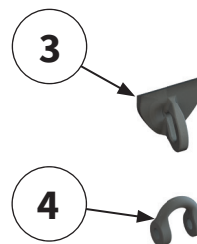

Pos.-Nr. No. Numéro Número	Ersatzteilnummer Manufacturer part number Numéro de pièce du fabricant Número de pieza del fabricante			DE Bezeichnung	EN Designation	FR Désignation	ES Designación
	Anzahl quantity quantité número						
	MU-C 120	MU-C 140	MU-C 160				
14	1	MU980203 1	1	Scheibe	washer	Disque	Arandela
15	1	MULI0001 1	1	Verschraubung	Screwed connection	Raccord à vis	Atornillamiento
16	0,17 m	MULI0005 0,17 m	0,17 m	Schmierleitung	lubrication line	Conduite de graissage	Tubería de engrase
17	1	MULI0003 1	1	Verschraubung	Screwed connection	Raccord à vis	Atornillamiento
18	1	MULI0004 1	1	Schmiernippel	lubricating nipple	Nipple de graissage	Engrasador
19	1	DIN71412A-H1-M06X1 1	1	Schmiernippel	lubricating nipple	Nipple de graissage	Engrasador



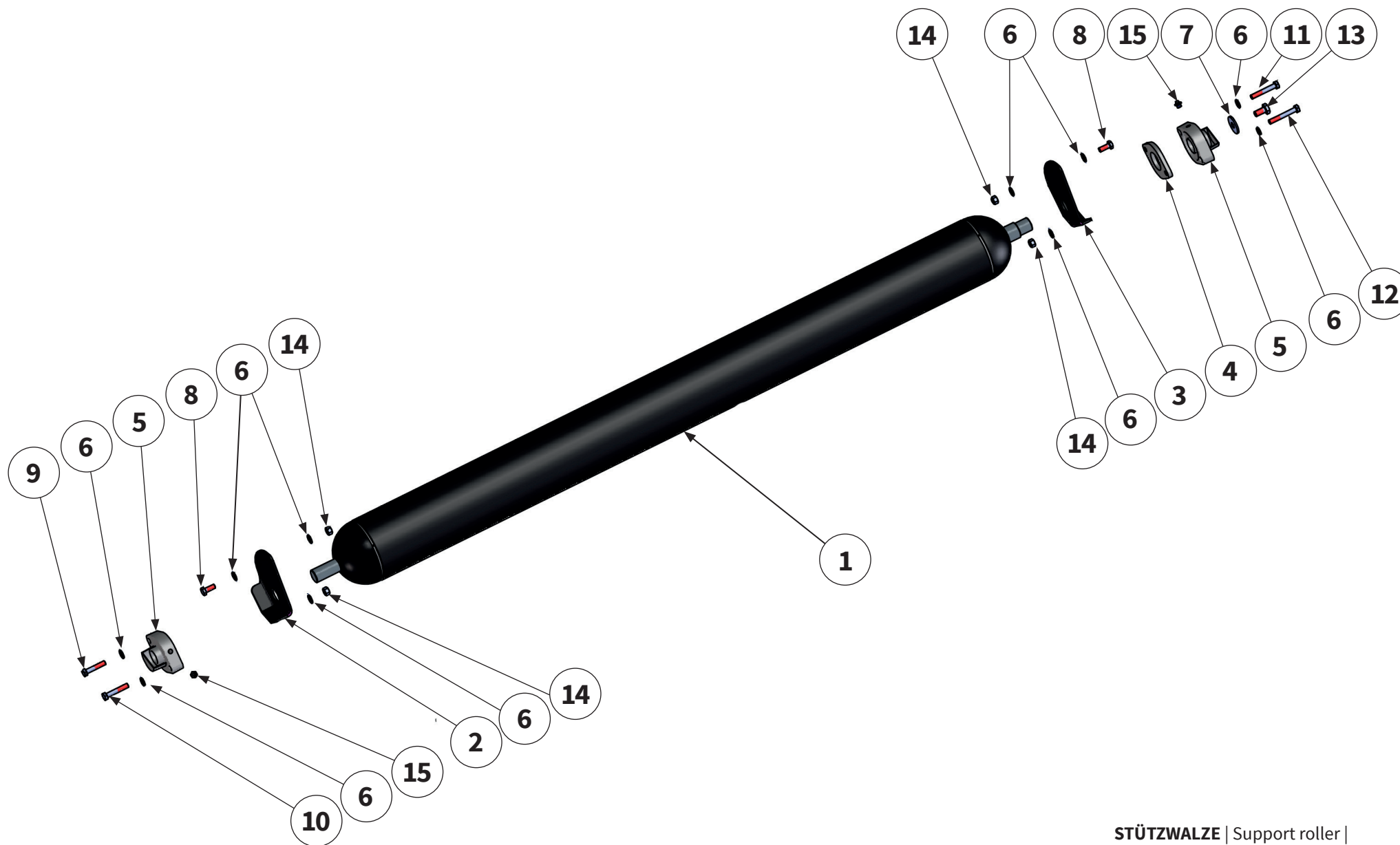

Pos.-Nr. No. Número	Ersatzteilnummer Manufacturer part number Numéro de pièce du fabricant Número de pieza del fabricante			DE Bezeichnung	EN Designation	FR Désignation	ES Designación
	Anzahl quantity quantité número						
	MU-C 120	MU-C 140	MU-C 160				
1	MU0110792 1	MU0110793 1	MU0110794 1	Stützwalze	support roller	Rouleau d'appui	Cilindro de apoyo
2	1	00015179 1	1	Flanschblech	flange plate	Plaque de bride	Chapa de bridas
3	1	00015180 1	1	Flanschblech	flange plate	Plaque de bride	Chapa de bridas
4	1	00001674 1	1	Platte	plate	Plaque	Placa
5	2	00001673 2	2	Flanschlager mit Kappe	flange with cap	Plaque de capuchon	Chapa de cubierta
5.1	2	KAPPE 2	2	Abdeckkappe	protective cap	Capuchon de protection	Cubierta protection
6	16	MU0099999 16	16	Scheibe	washer	Disque	Arandela
7	1	MU0099992 1	1	Scheibe	washer	Disque	Arandela
8	4	MU980115 4	4	Schraube	washer	Disque	Arandela
9	1	MU980128 1	1	Schraube	bolt	Vis	Tornillo
10	1	MU980116 1	1	Schraube	bolt	Vis	Tornillo
11	1	MU980119 1	1	Schraube	bolt	Vis	Tornillo
12	1	MU980118 1	1	Schraube	bolt	Vis	Tornillo



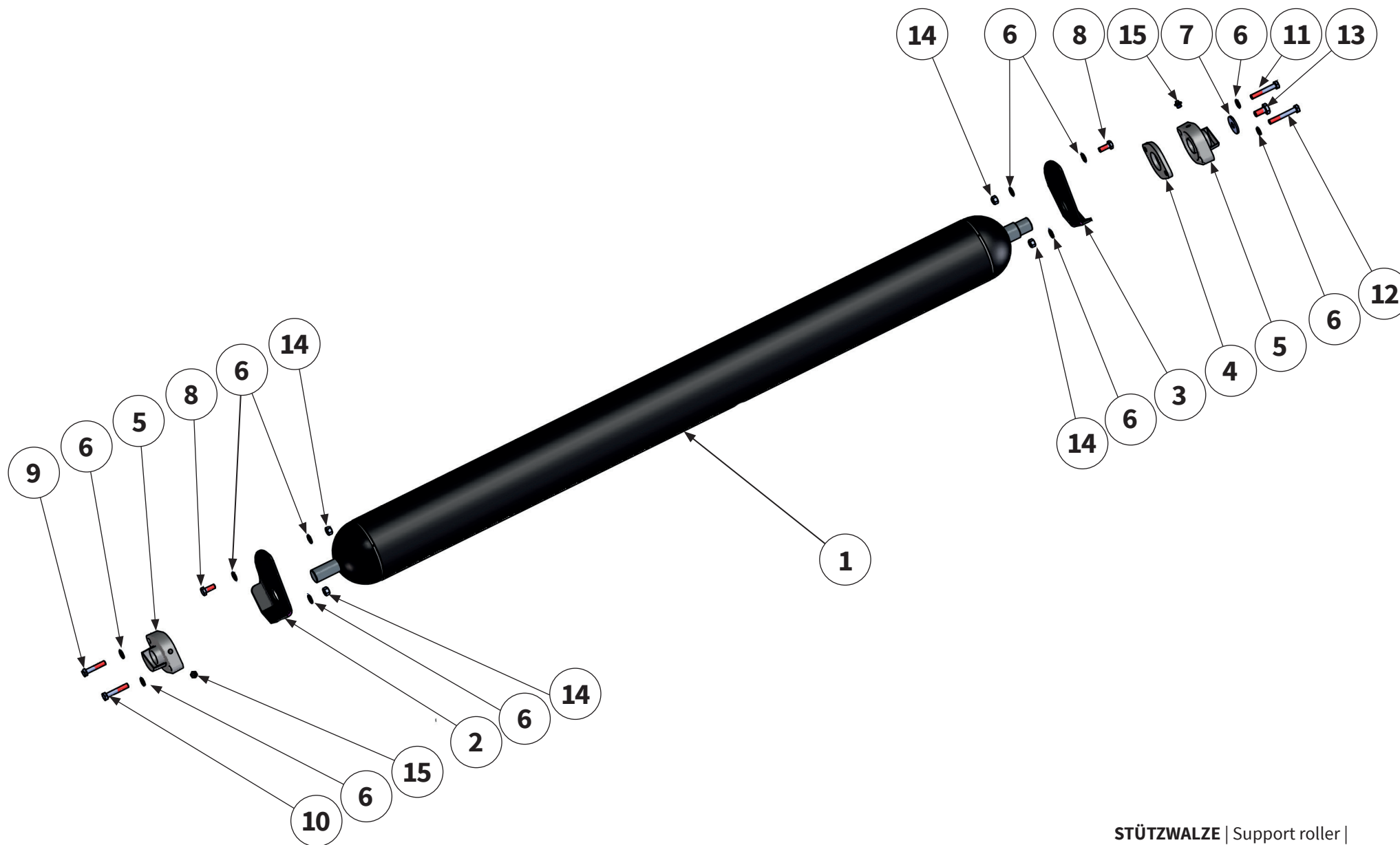

Pos.-Nr. No. Numéro Número	Ersatzteilnummer Manufacturer part number Numéro de pièce du fabricant Número de pieza del fabricante			DE Bezeichnung	EN Designation	FR Désignation	ES Designación
	Anzahl quantity quantité número						
	MU-C 120	MU-C 140	MU-C 160				
13	MU0099970			Schraube	bolt	Vis	Tornillo
	1	1	1				
14	MU0099961			Mutter	nut	Écrou	Tuerca
	8	8	8				
15	DIN71412C-H3-M06X1			Schmiernippel	lubricating nipple	Nipple de graissage	Engrasador
	2	2	2				

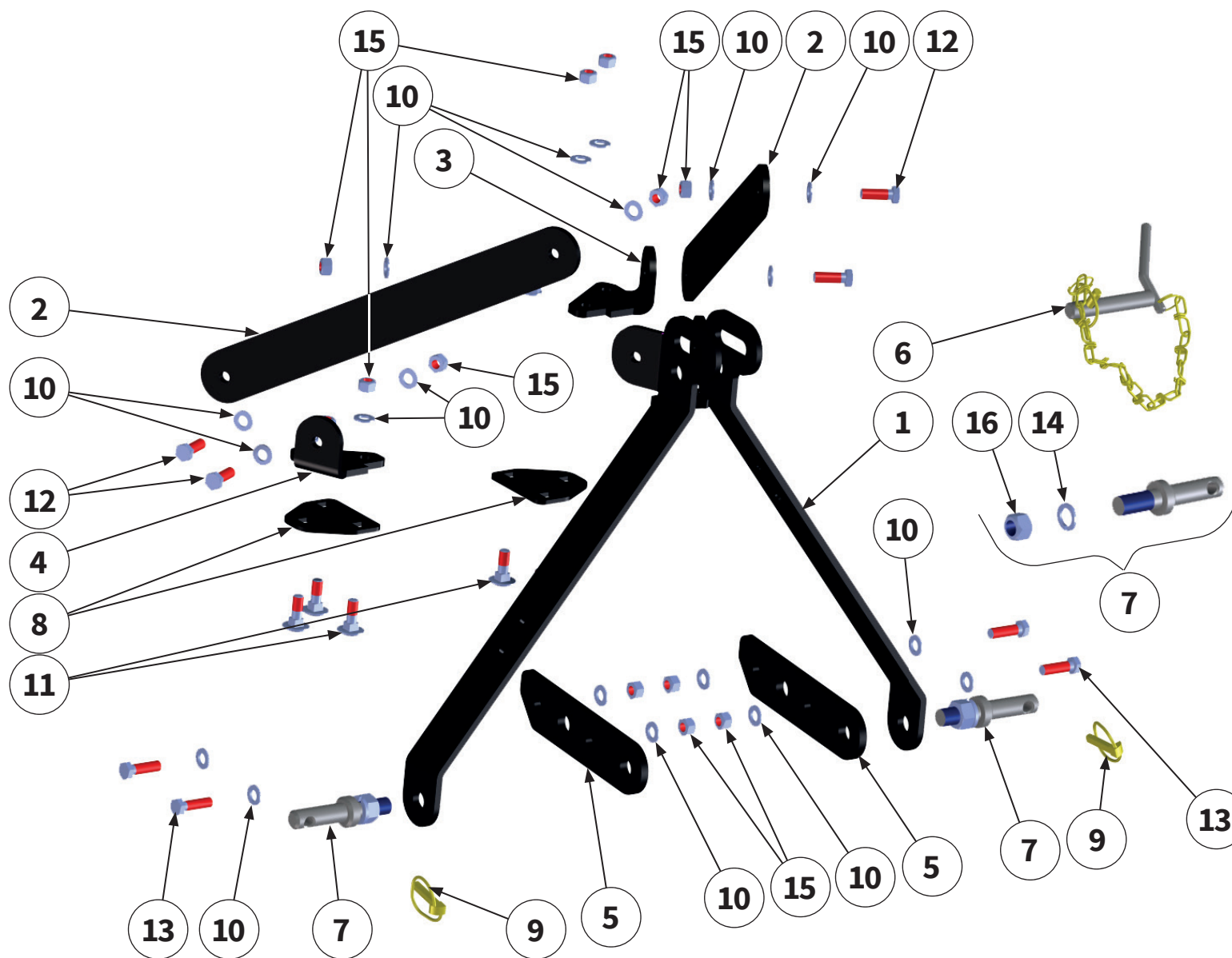

Pos.-Nr. No. Número	Ersatzteilnummer Manufacturer part number Numéro de pièce du fabricant Número de pieza del fabricante			DE Bezeichnung	EN Designation	FR Désignation	ES Designación
	Anzahl quantity quantité número						
	MU-C 120	MU-C 140	MU-C 160				
1	1	00011143 1	1	Dreipunktbock	3-point trestle	Support d'attelage trois point	Soporte de tres apoyos
2	2	00010868 2	2	Strebe	strut	Jambe de force	Tirante
3	1	MU0503032 1	1	Halter links	holder left	Support à gauche	Soporte a la izquierda
4	1	MU0503031 1	1	Halter rechts	holder right	Support à droite	Soporte a la derecha
5	2	MU0503061 2	2	Unterlenkerauf- nahme	lower link receiver	Logement du bras inférieur	Alojamiento del brazo inferior
6	1	00005545 1	1	Bolzen mit Kette	pin with chain	Axe avec Chaîne	Perno con Cadena
7	2	MU0501996 2	2	Bolzen kpl.	pin complete	Axe complet	Perno completo
8	2	00004053 2	2	Distanzblech	spacer plate	Tôle d'écartement	Chapa distanciadora
9	2	MU0099948 2	2	Klappstecker	lynch pin	Esse d'essieu	Pasador abatible
10	22	MU980302 22	22	Scheibe	washer	Disque	Arandela
11	6	MU980320 6	6	Schraube	bolt	Vis	Tornillo
12	4	MU980311 4	4	Schraube	bolt	Vis	Tornillo
13	4	MU980328 4	4	Schraube	bolt	Vis	Tornillo

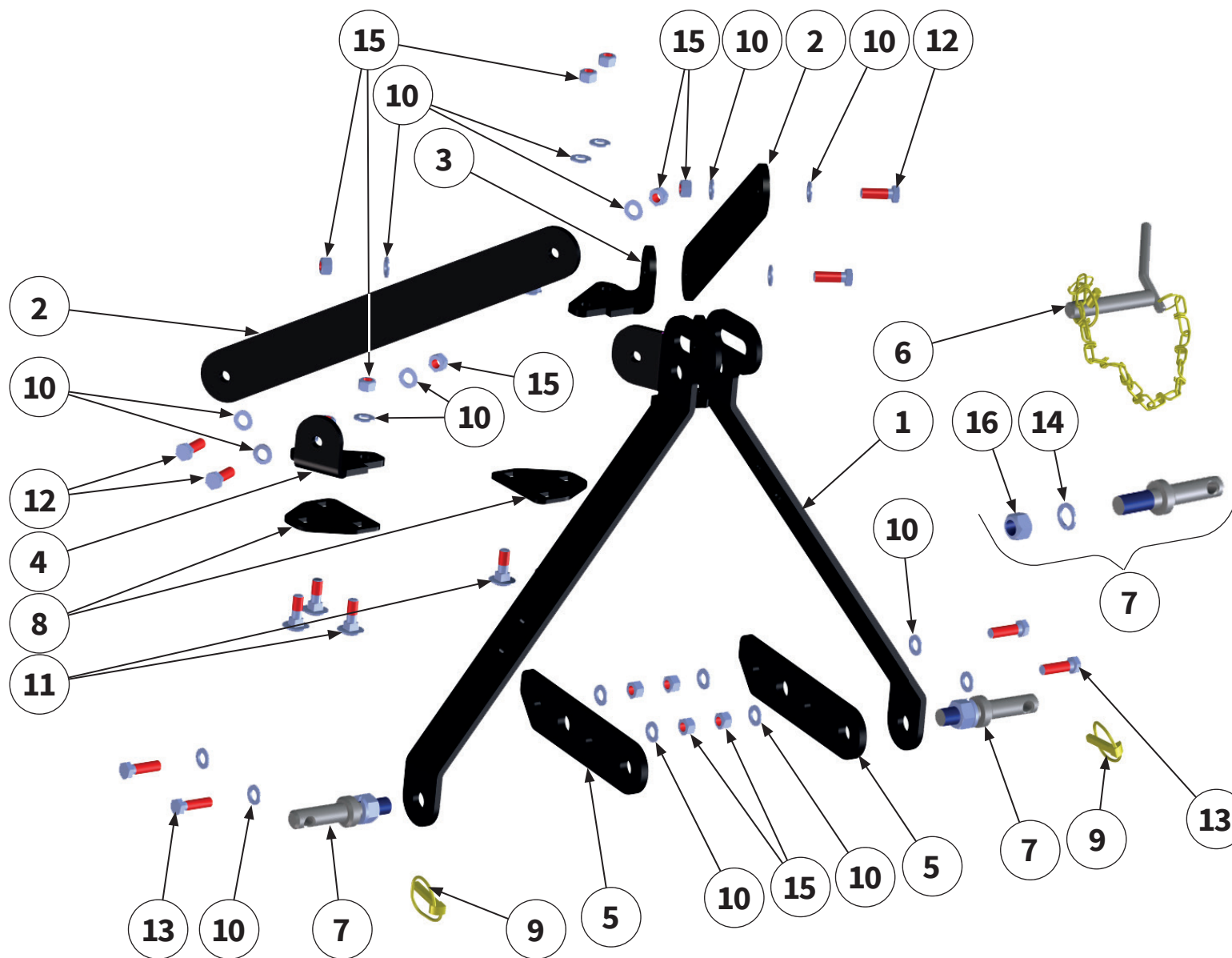

Pos.-Nr. No. Numéro Número	Ersatzteilnummer Manufacturer part number Numéro de pièce du fabricant Número de pieza del fabricante			DE Bezeichnung	EN Designation	FR Désignation	ES Designación
	Anzahl quantity quantité número						
	MU-C 120	MU-C 140	MU-C 160				
14	MU982030			Federring	spring washer	Rondelle élastique	Anillo elástico
	2	2	2				
15	MU0099960			Mutter	nut	Écrou	Tuerca
	14	14	14				
16	MU980260			Mutter	nut	Écrou	Tuerca
	2	2	2				

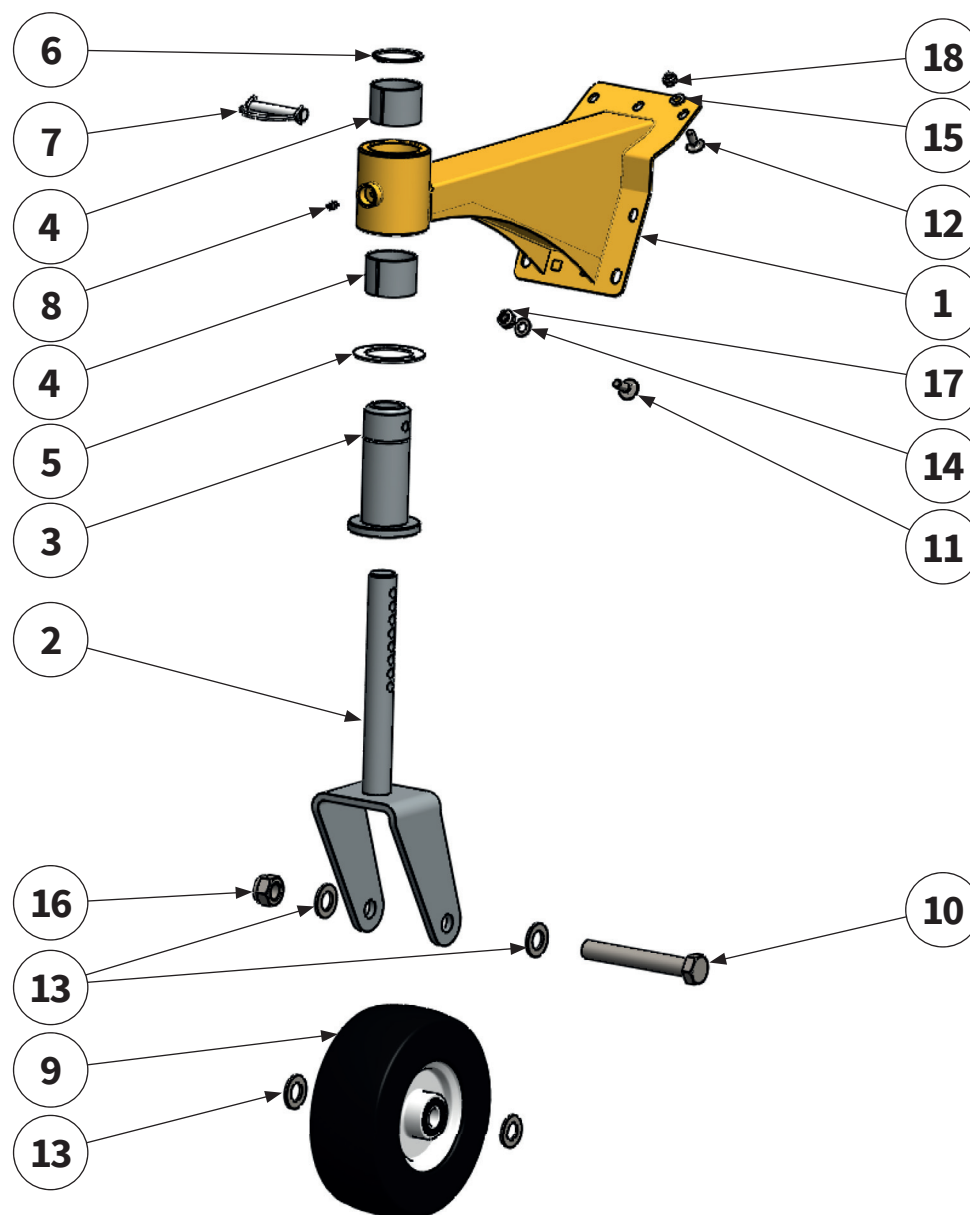

Pos.-Nr. No. Número	Ersatzteilnummer Manufacturer part number Numéro de pièce du fabricant Número de pieza del fabricante			DE Bezeichnung	EN Designation	FR Désignation	ES Designación
	Anzahl quantity quantité número						
	MU-C 120	MU-C 140	MU-C 160				
1	1	00031225 1	1	Stützradträger	support wheel carrier	Support de la roue d' appui	Soporte de la rueda de soporte
2	1	MU0110751 1	1	Radgabel	wheel yoke	Fourche de roue	Horquilla de rueda
3	2	MU0211071 2	2	Buchse	bush	Douille	Casquillo
4	2	MU0211111 2	2	Gleitlagerbuchse	plain bearing bush	Coussinet lisse	Casquillo de cojinete liso
5	1	MU0211101 1	1	Anlaufscheibe	thrust washer	Rondelle de butée	Arandela de tope
6	1	MU0099990 1	1	Sicherungsring	circlip	Bague de sécurite	Anillo de seguridad
7	1	MU0099946 1	1	Rohrklappstecker	pipe lynch pin	Goupille rabattable	Conector de tapa de tubo
8	1	DIN71412A-H1-M06X1 1	1	Schmiernippel	lubricating nipple	Nipple de graissage	Engrasador
9	1	MU0211091-3 1	1	Stützrad	support wheel	Roue d' appui	Rueda de soporte
10	1	MU0099977 1	1	Schraube	bolt	Vis	Tornillo



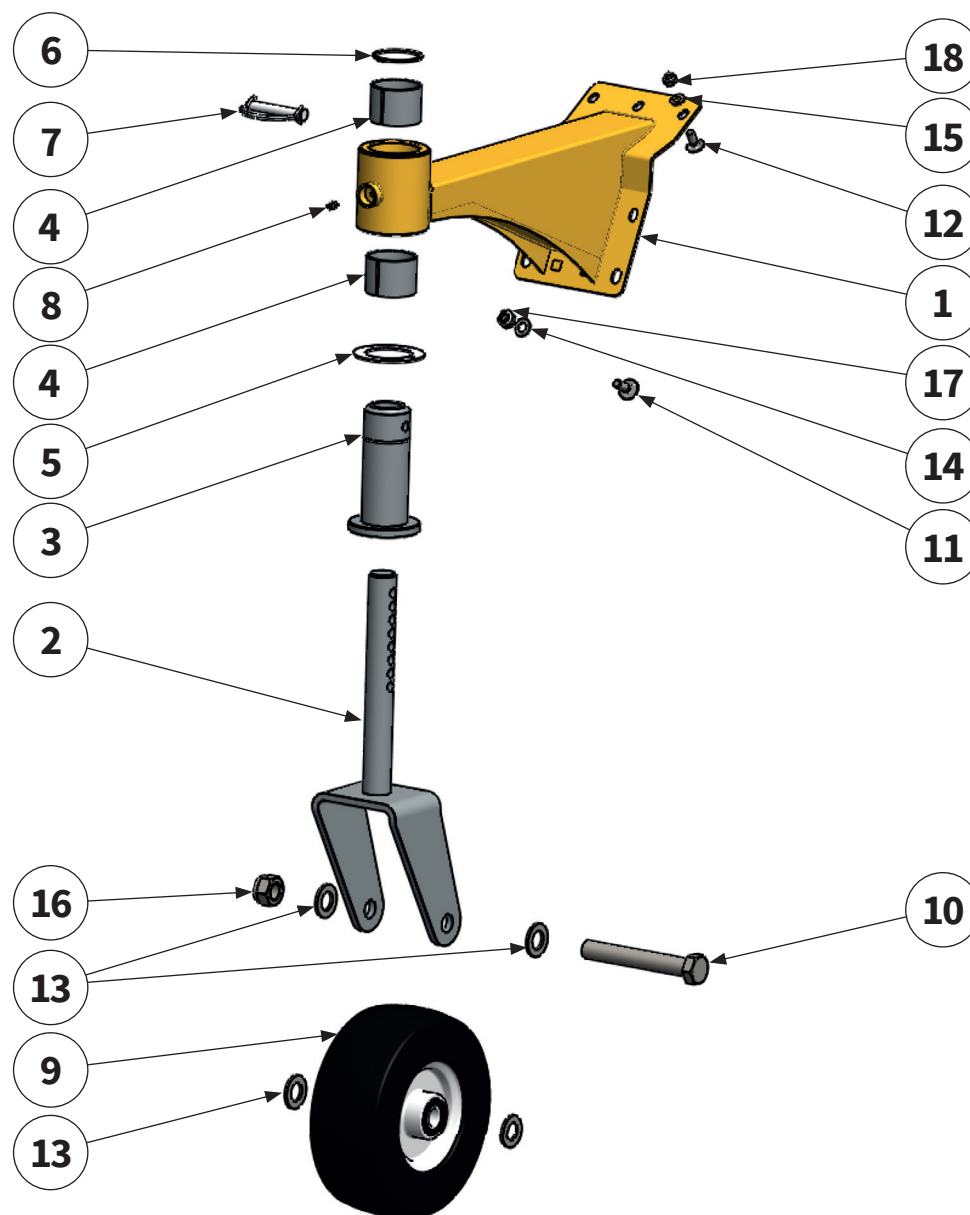

Pos.-Nr. No. Numéro Número	Ersatzteilnummer Manufacturer part number Numéro de pièce du fabricant Número de pieza del fabricante			DE Bezeichnung	EN Designation	FR Désignation	ES Designación
	Anzahl quantity quantité número						
	MU-C 120	MU-C 140	MU-C 160				
11	00000903			Schraube	bolt	Vis	Tornillo
	2	2	2				
12	MU980107			Schraube	bolt	Vis	Tornillo
	5	5	5				
13	MU980505			Scheibe	washer	Disque	Arandela
	4	4	4				
14	MU980202			Scheibe	washer	Disque	Arandela
	2	2	2				
15	MU0099999			Scheibe	washer	Disque	Arandela
	5	5	5				
16	MU0099959			Mutter	nut	Écrou	Tuerca
	1	1	1				
17	MU0099960			Mutter	nut	Écrou	Tuerca
	2	2	2				
18	MU0099961			Mutter	nut	Écrou	Tuerca
	5	5	5				



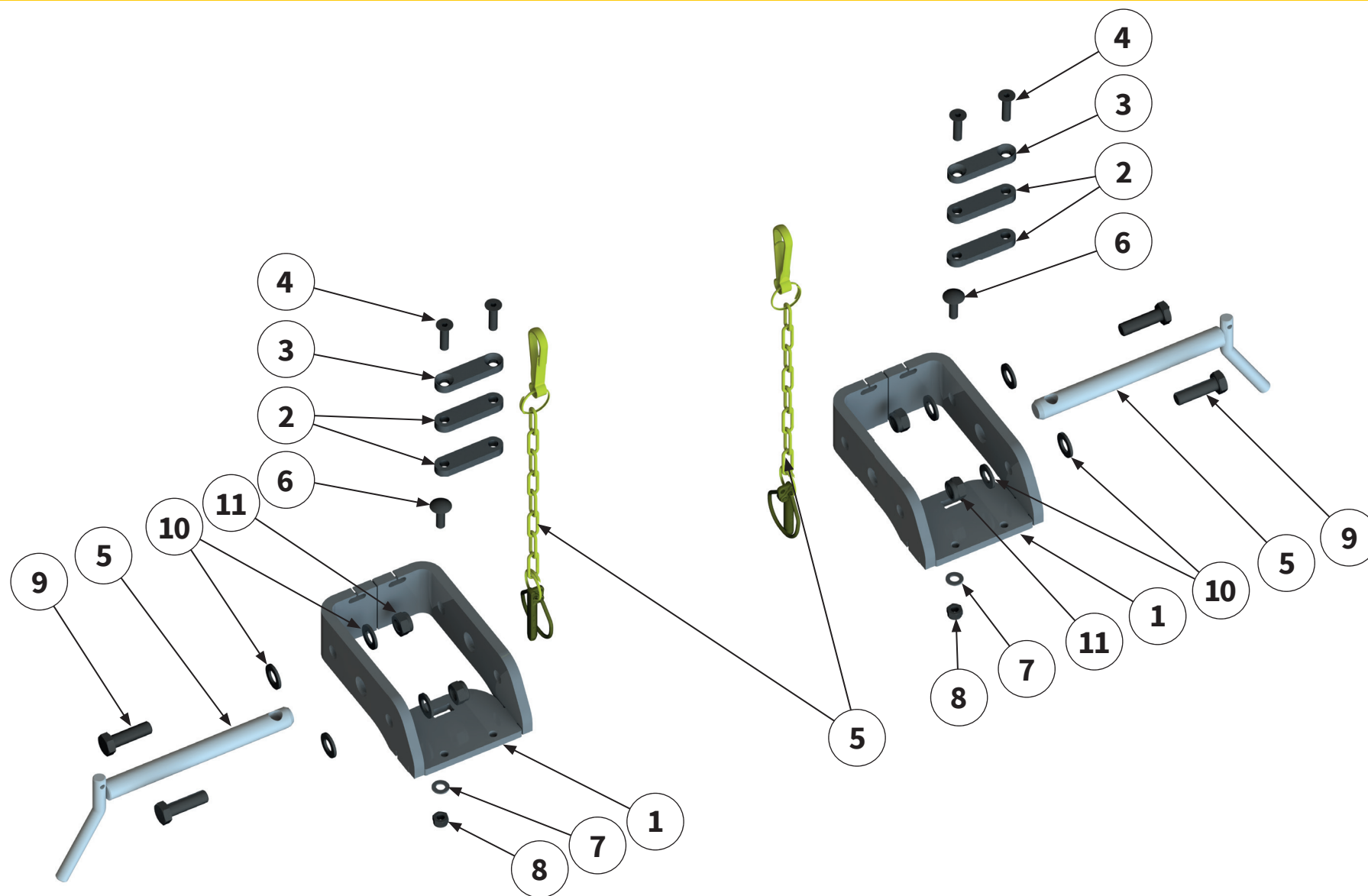

Pos.-Nr. No. Número	Ersatzteilnummer Manufacturer part number Numéro de pièce du fabricant Número de pieza del fabricante			DE Bezeichnung	EN Designation	FR Désignation	ES Designación
	Anzahl quantity quantité número						
	MU-C 120	MU-C 140	MU-C 160				
1	2	00014797 2	2	Unterlenkeraufnahme	lower link receiver	Logement du bras inférieur	Alojamiento del brazo inferior
2	4	00014793 4	4	Distanzblech	spacer plate	Tôle d'écartement	Chapa distanciadora
3	2	00014792 2	2	Blech	sheet metal	Tôle	Chapa
4	4	MU0099952 4	4	Schraube	bolt	Vis	Tornillo
5	2	00001787 2	2	Bolzen mit Kette	pin with chain	Axe avec Chaîne	Perno con Cadena
6	2	MU0099988 2	2	Schraube	bolt	Vis	Tornillo
7	2	MU0099999 2	2	Scheibe	washer	Disque	Arandela
8	2	MU0099961 2	2	Mutter	nut	Écrou	Tuerca
9	4	MU980328 4	4	Schraube	bolt	Vis	Tornillo
10	8	MU980302 8	8	Scheibe	washer	Disque	Arandela
11	4	MU980301 4	4	Mutter	nut	Écrou	Tuerca



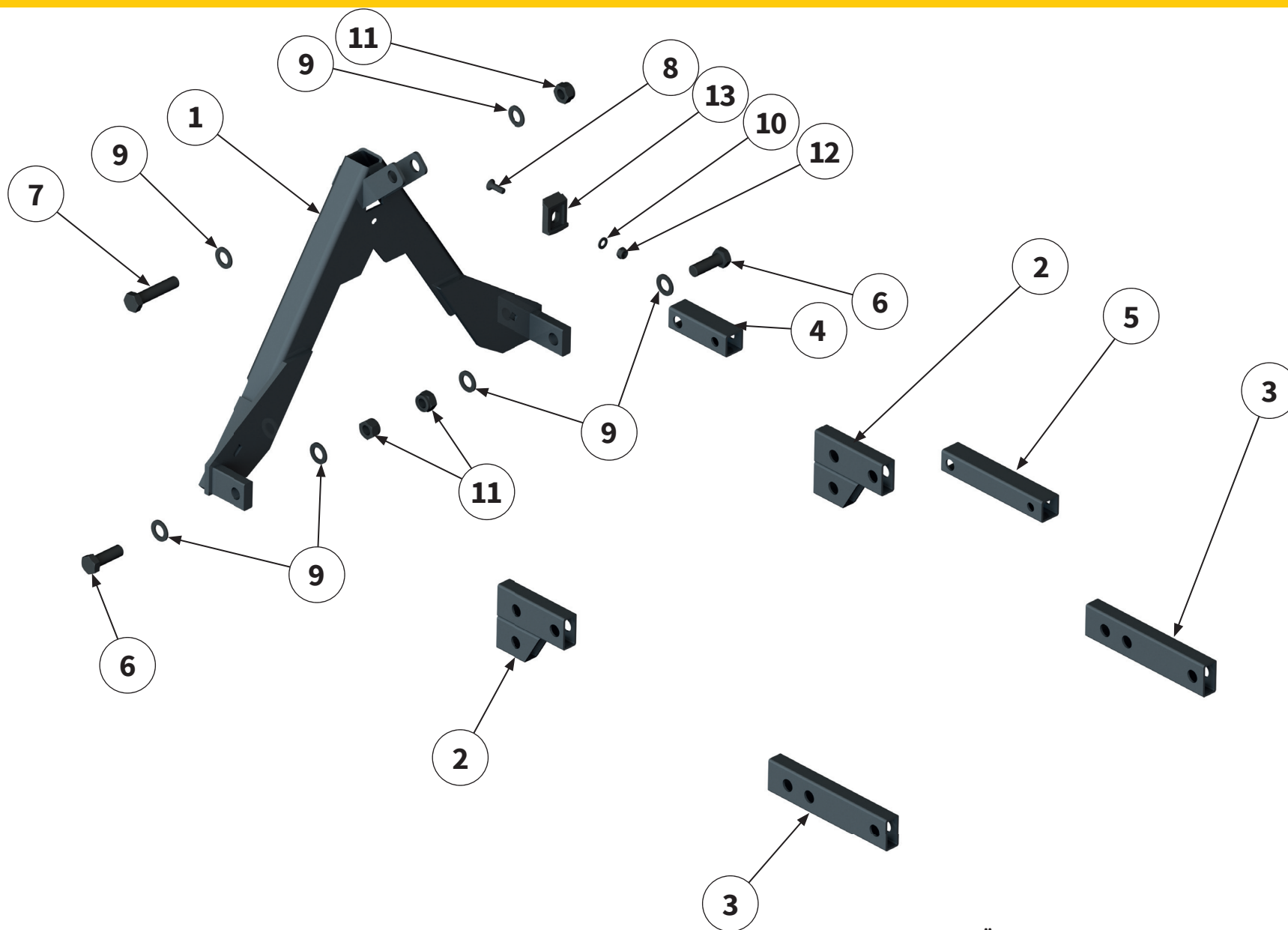

Pos.-Nr. No. Número	Ersatzteilnummer Manufacturer part number Numéro de pièce du fabricant Número de pieza del fabricante			DE Bezeichnung	EN Designation	FR Désignation	ES Designación
	Anzahl quantity quantité número						
	MU-C 120	MU-C 140	MU-C 160				
1	1	00014510 1	1	Gerätedreieck	implement triangle	Triangle d'attelage	Triángulo del dispositivo
2	2	00030696 2	2	Unterlenker- aufnahme	lower link receiver	Logement du bras inférieur	Alojamiento del brazo inferior
3	2	00014514 2	2	Profilrohr	section tube	Tube de section	Tubo de sección
4	1	00014511 1	1	Profilrohr	section tube	Tube de section	Tubo de sección
5	1	00014512 1	1	Profilrohr	section tube	Tube de section	Tubo de sección
6	2	MU981008 2	2	Schraube	bolt	Vis	Tornillo
7	1	MU980529 1	1	Schraube	bolt	Vis	Tornillo
8	1	MU980252 1	1	Schraube	bolt	Vis	Tornillo
9	6	MU980505 6	6	Scheibe	washer	Disque	Arandela
10	1	MU980202 1	1	Scheibe	washer	Disque	Arandela
11	3	MU0099959 3	3	Mutter	nut	Écrou	Tuerca
12	1	MU0099960 1	1	Mutter	nut	Écrou	Tuerca
13	1	MU0011071 1	1	Sperrklinke	detent freewheel	Cliquet d'arrêt roue libre	Trinquete de bloqueo rueda libre



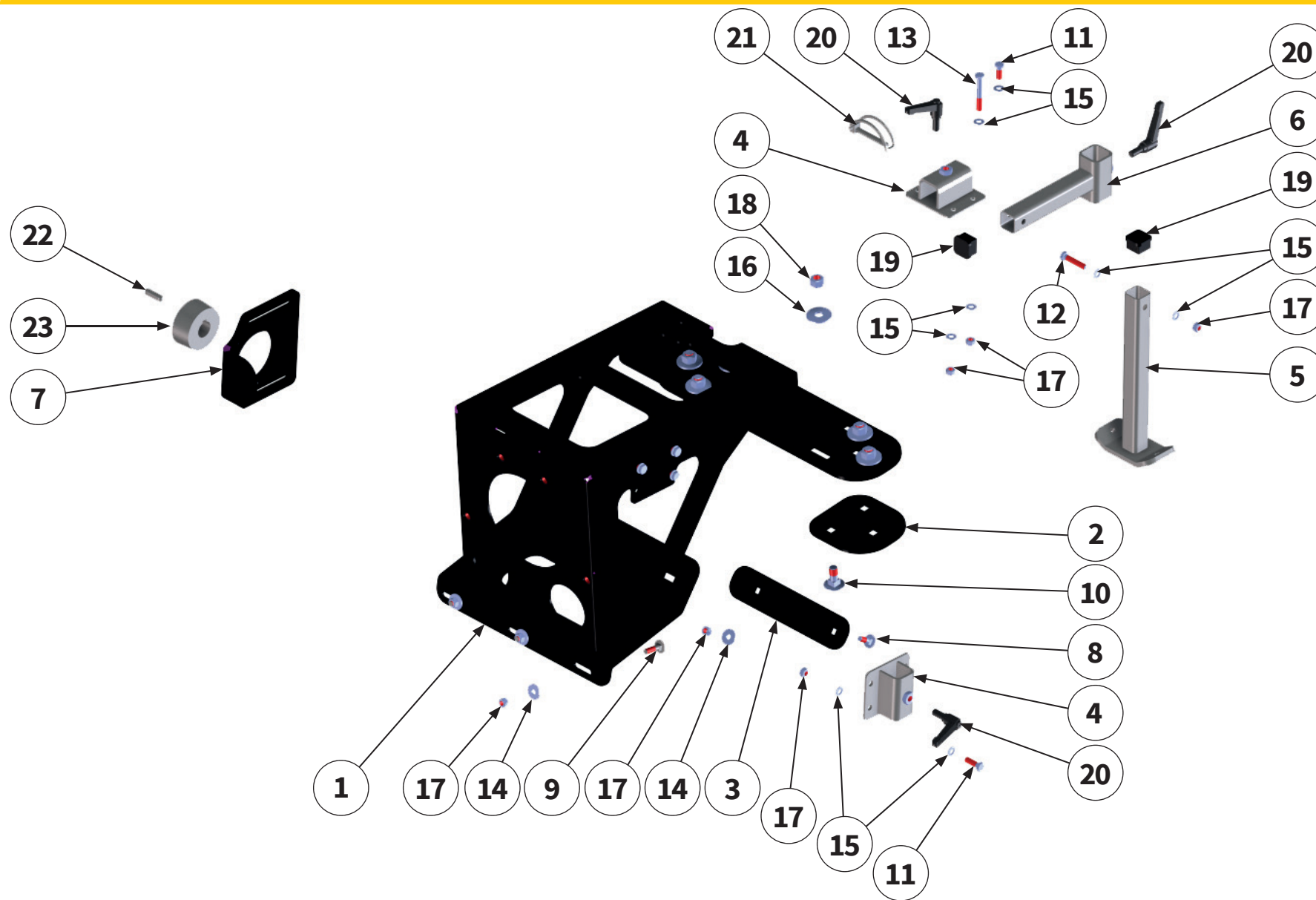

Pos.-Nr. No. Número	Ersatzteilnummer Manufacturer part number Numéro de pièce du fabricant Número de pieza del fabricante			DE Bezeichnung	EN Designation	FR Désignation	ES Designación
	Anzahl quantity quantité número						
	MU-C 120	MU-C 140	MU-C 160				
1	1	00014770 1	1	Konsole	Console	Console	Consola
2	2	00014745 2	2	Platte	plate	Plaque	Placa
3	1	00014746 1	1	Platte	plate	Plaque	Placa
4	2	00001134 2	2	Stützenhalter	support bracket	Supports de stationnement	soporte de apoyo
5	1	00001101 1	1	Abstellstütze	support leg	Béquille de stationnement	Pie de apoyo
6	1	00001137 1	1	Halter	holder	Support	Soporte
7	1	00014772 1	1	Spannblech	clamping plate	Plaque de serrage	Chapa de sujeción
8	2	MU0099988 2	2	Schraube	bolt	Vis	Tornillo
9	3	MU0099987 3	3	Schraube	bolt	Vis	Tornillo
10	6	MU980310 6	6	Schraube	bolt	Vis	Tornillo
11	6	MU980109 6	6	Schraube	bolt	Vis	Tornillo
12	1	MU980112 1	1	Schraube	bolt	Vis	Tornillo
13	2	MU980118 2	2	Schraube	bolt	Vis	Tornillo



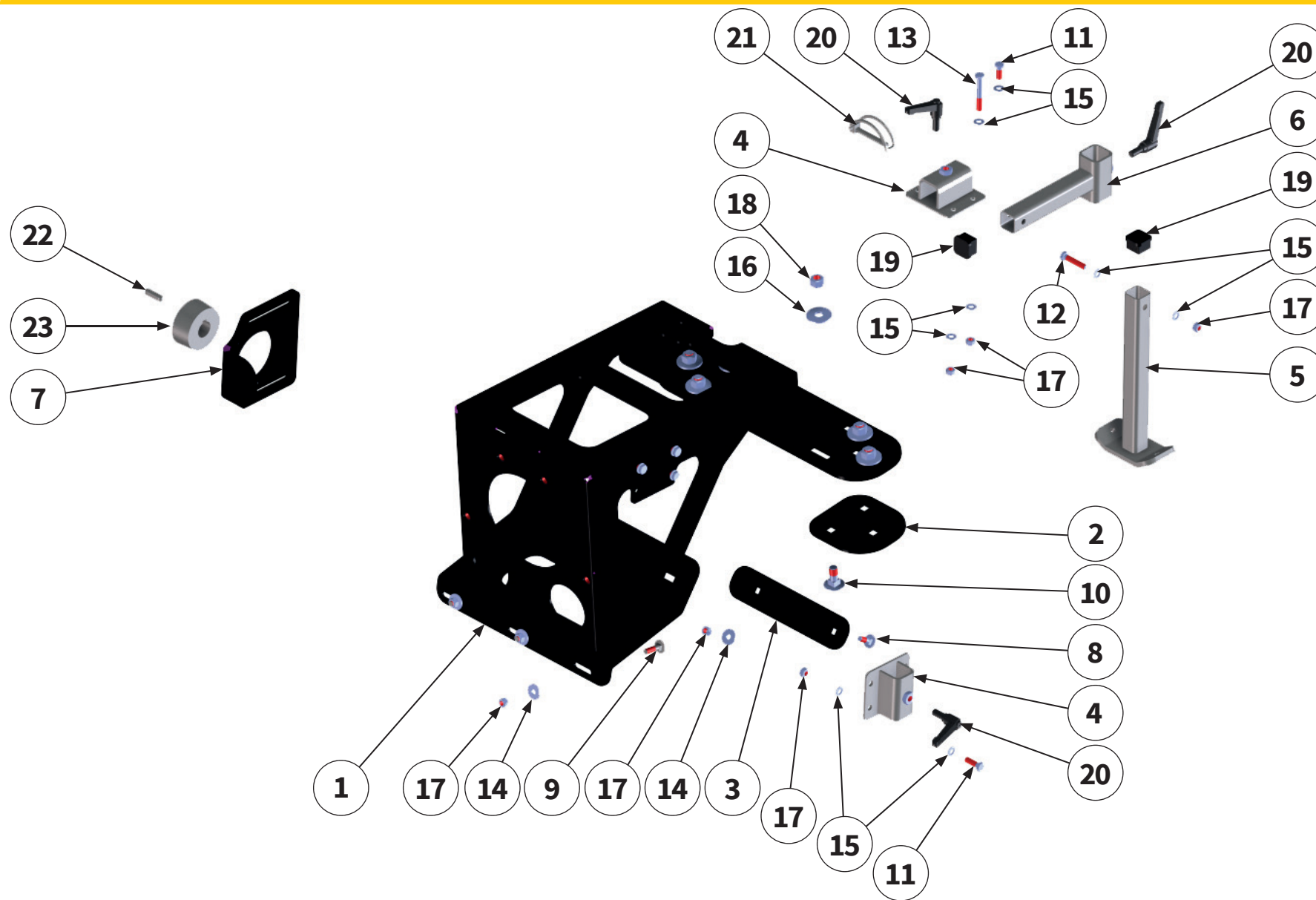

Pos.-Nr. No. Número	Ersatzteilnummer Manufacturer part number Numéro de pièce du fabricant Número de pieza del fabricante			DE Bezeichnung	EN Designation	FR Désignation	ES Designación
	Anzahl quantity quantité número						
	MU-C 120	MU-C 140	MU-C 160				
14	5	MU0099951 5	5	Scheibe	washer	Disque	Arandela
15	18	MU0099999 18	18	Scheibe	washer	Disque	Arandela
16	6	MU980203 6	6	Scheibe	washer	Disque	Arandela
17	14	MU0099961 14	14	Mutter	nut	Écrou	Tuerca
18	6	MU980301 6	6	Mutter	nut	Écrou	Tuerca
19	2	00003433 2	2	Verschlußstopfen	sealing plug	Bouchon de fermeture	Tapón de cierre
20	3	00015825 3	3	Klemmhebel	clamping lever	Levier de serrage	Palanca de sujeción
21	1	00005605 1	1	Rohrklappstecker	pipe lynch pin	Goupille rabattable	Conector de tapa de tubo
22	1	MU280027 1	1	Paßfeder	parallel key	Clavette	Chaveta de ajuste
23	1	MU0501999 1	1	Spannbuchse	clamping bush	Douille de serrage	Manguito de su- jeción



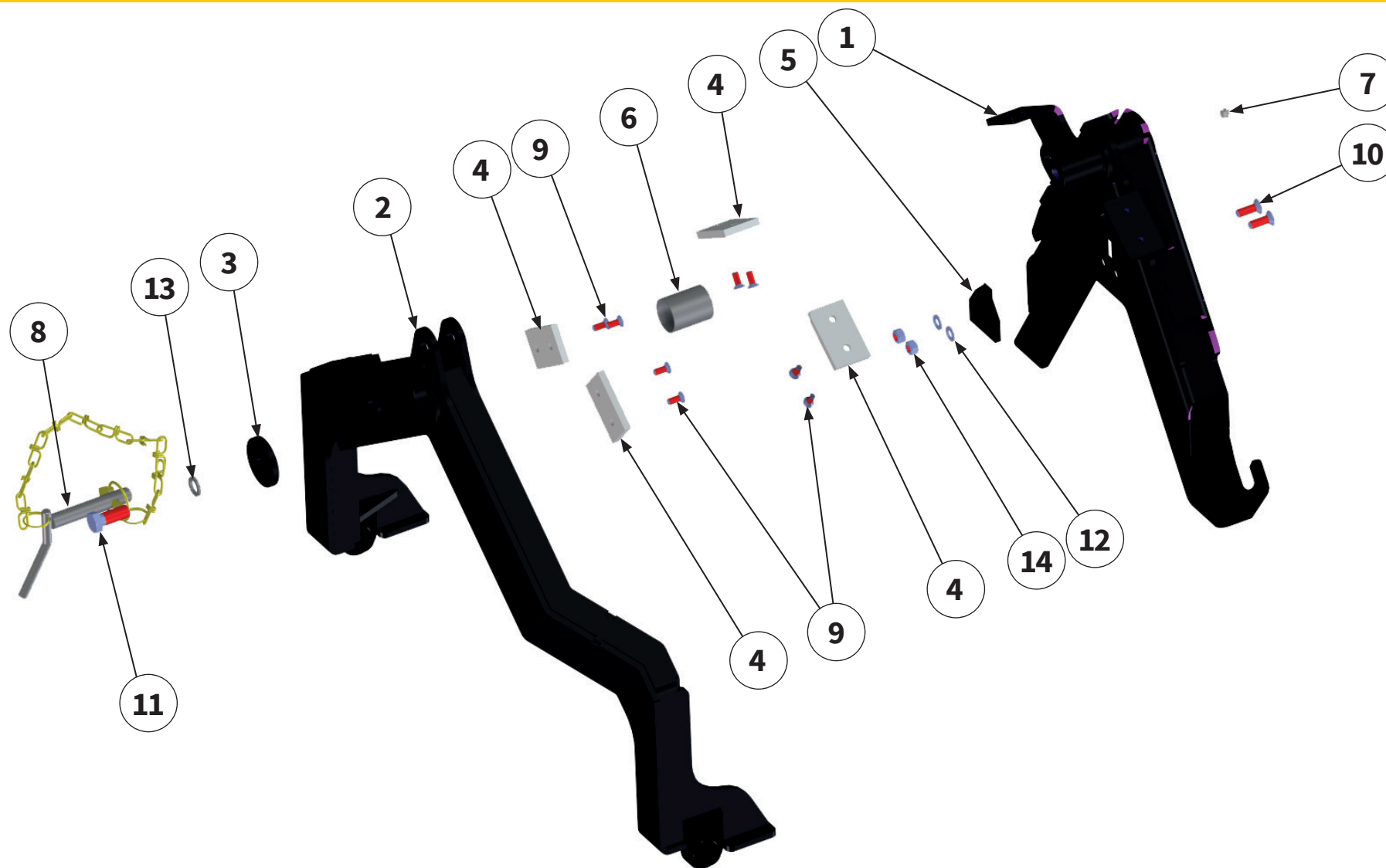

Pos.-Nr. No. Número	Ersatzteilnummer Manufacturer part number Numéro de pièce du fabricant Número de pieza del fabricante			DE Bezeichnung	EN Designation	FR Désignation	ES Designación
	Anzahl quantity quantité número						
	MU-C 120	MU-C 140	MU-C 160				
1	1	00014163 1	1	Gerätedreieck	implement triangle	Triangle d'attelage	Triángulo del dispositivo
2	1	00015343 1	1	Schwinge	linkage	Balancier	Balancín
3	1	00009771 1	1	Scheibe	washer	Disque	Arandela
4	4	00003768 4	4	Gleitplatte	slide plate	Plaque de glissement	Placa deslizante
5	1	00014169 1	1	Sperrplatte	locking plate	Plaque de verrouillage	Placa de bloqueo
6	1	00009950 1	1	Gleitlager	sleeve bearing	Palier lisse	Cojinete de deslizamiento
7	1	DIN71412A-H1-M10X1 1	1	Schmiernippel	lubricating nipple	Nipple de graissage	Engrasador
8	1	00005545 1	1	Oberlenkerbolzen	upper link pin	Boulon de liaison supérieure	Perno de enlace superior
9	8	MU980134 8	8	Schraube	bolt	Vis	Tornillo
10	2	MU980252 2	2	Schraube	bolt	Vis	Tornillo
11	1	MU980412 1	1	Schraube	bolt	Vis	Tornillo
12	2	MU980202 2	2	Scheibe	washer	Disque	Arandela
13	1	MUNL0016 1	1	Scheibe	washer	Disque	Arandela
14	2	MU0099960 2	2	Mutter	nut	Écrou	Tuerca

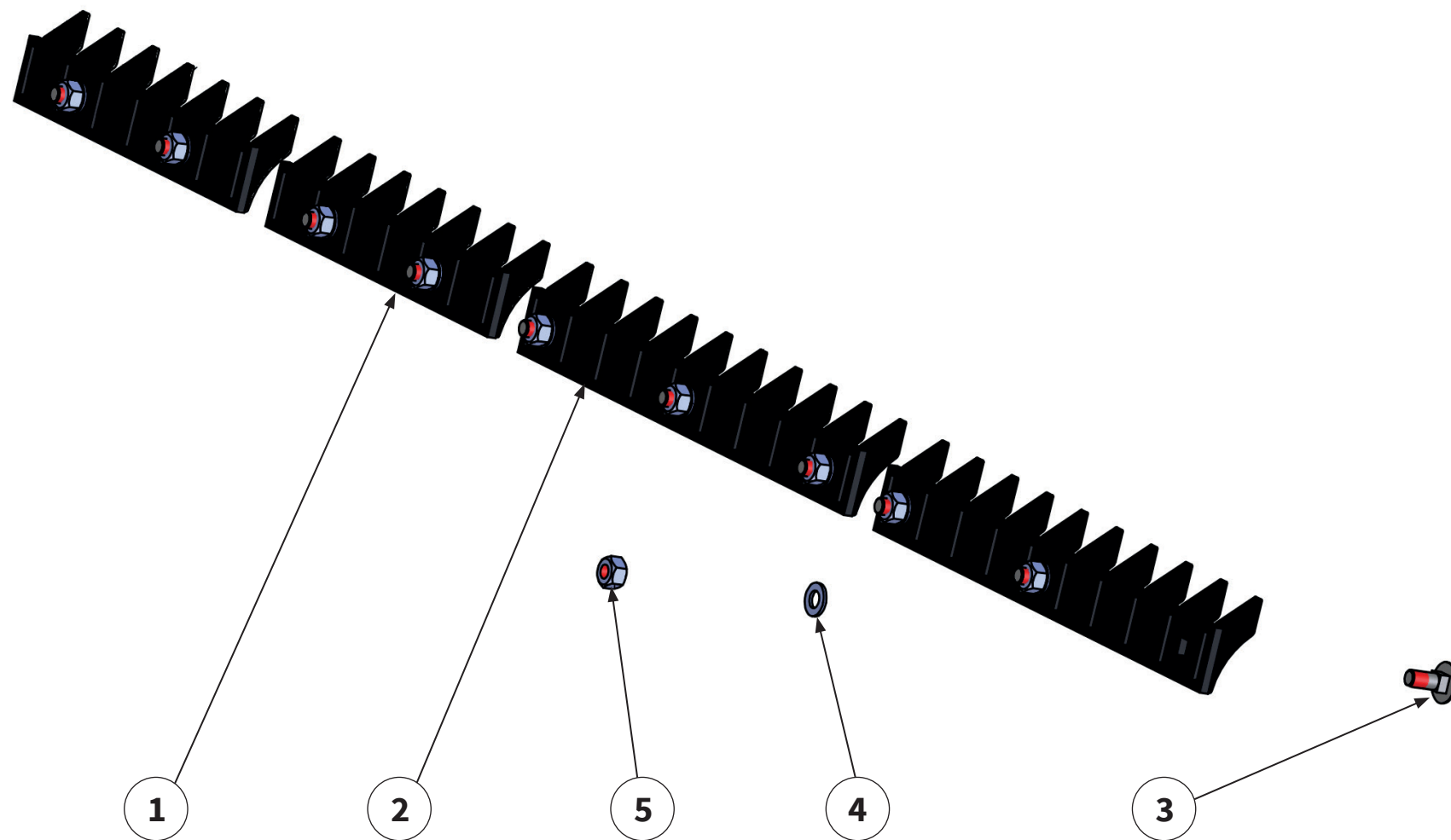

Pos.-Nr. No. Numéro Número	Ersatzteilnummer Manufacturer part number Numéro de pièce du fabricant Número de pieza del fabricante			DE Bezeichnung	EN Designation	FR Désignation	ES Designación
	Anzahl quantity quantité número						
	MU-C 120	MU-C 140	MU-C 160				
1	-	00005472 2	-	Gegenschneide 300	short-chopping bar	Lame hache-paille courte	Listón de corte de paja corto
2	3	00005474 2	4	Gegenschneide 400	short-chopping bar	Lame hache-paille courte	Listón de corte de paja corto
3	9	00000903 10	12	Schraube	bolt	Vis	Tornillo
4	9	MU980202 10	12	Scheibe	washer	Disque	Arandela
5	9	MU0099960 10	12	Mutter	nut	Écrou	Tuerca



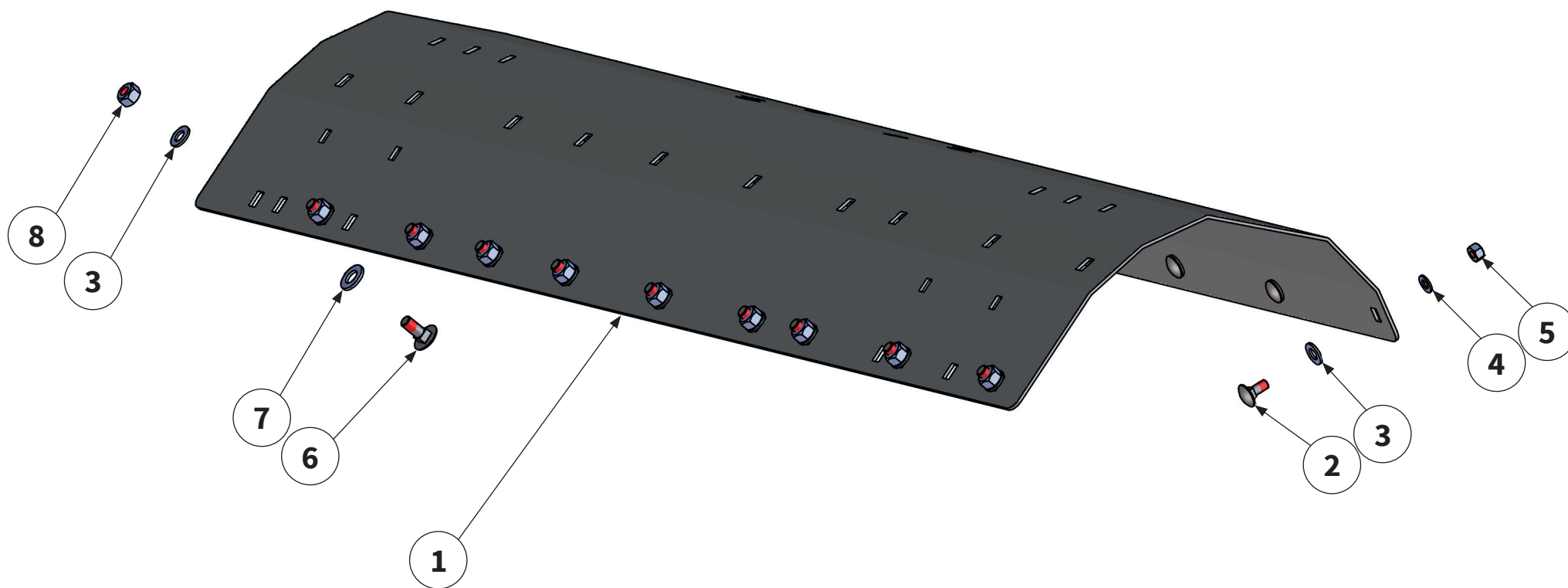

Pos.-Nr. No. Numéro Número	Ersatzteilnummer Manufacturer part number Numéro de pièce du fabricant Número de pieza del fabricante			DE Bezeichnung	EN Designation	FR Désignation	ES Designación
	Anzahl quantity quantité número						
	MU-C 120	MU-C 140	MU-C 160				
1	00010881 1	00010914 1	00010957 1	Verschleißeinlage	wear insert	Blindage	Junta de desgaste
2	7	MU980107 9	9	Schraube	bolt	Vis	Tornillo
3	16	MU980202 19	21	Scheibe	washer	Disque	Arandela
4	7	MU0099999 9	9	Scheibe	washer	Disque	Arandela
5	7	MU0099961 9	9	Mutter	nut	Écrou	Tuerca
6	10	00000903 10	12	Schraube	bolt	Vis	Tornillo
7	9	MU980302 10	12	Scheibe	washer	Disque	Arandela
8	9	MU0099960 10	12	Mutter	nut	Écrou	Tuerca



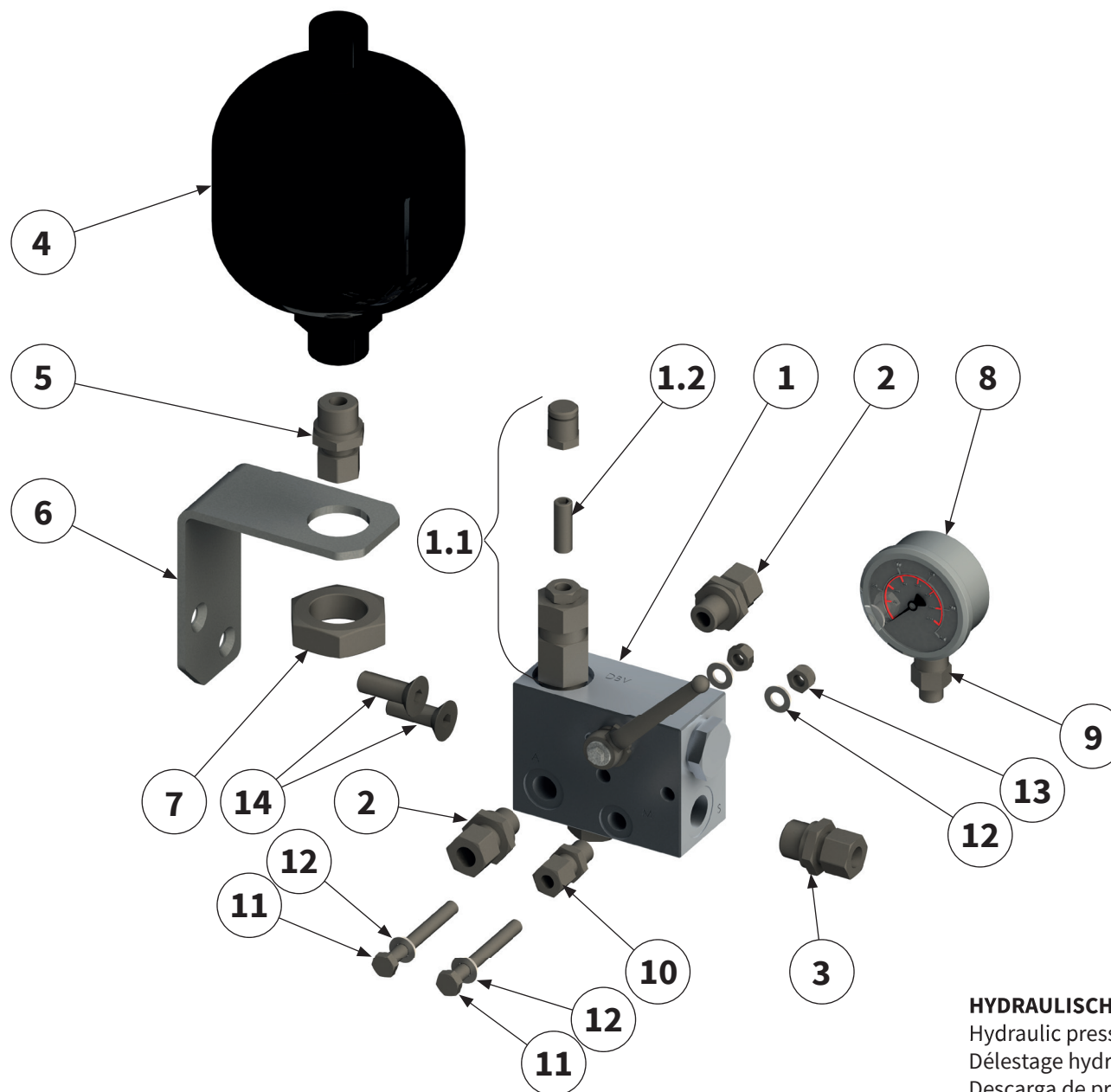

HYDRAULISCHE DRUCKENTLASTUNG MU-SOFA |
 Hydraulic pressure relief MU-SOFA |
 Délestage hydraulique MU-SOFA |
 Descarga de presión hidráulica MU-SOFA |

Pos.-Nr. No. Número	Ersatzteilnummer Manufacturer part number Numéro de pièce du fabricant Número de pieza del fabricante			DE Bezeichnung	EN Designation	FR Désignation	ES Designación
	Anzahl quantity quantité número						
	MU-C 120	MU-C 140	MU-C 160				
1	1552600			Ventilblock	Valve block	Bloc de soupapes	Bloque de válvulas
	1	1	1				
1.1	180352			Ventileinsatz	Valve core	Garniture de s oupape	Inserto de válvula
	1	1	1				
1.2	209343			Gewindestift	threaded pin	Tige filetée	Perno roscado
	1	1	1				
2	GE-12-PLR-3/8			Verschraubung	Screwed connection	Raccord à vis	Atornillamiento
	2	2	2				
3	GE-12-PLR-1/2			Verschraubung	Screwed connection	Raccord à vis	Atornillamiento
	1	1	1				
4	209162			Stickstoffspeicher	Nitrogen accumulator	Poche d'azote	Burbuja de nitrógeno
	1	1	1				
5	GE-12-PLM-22X1.5			Verschraubung	Screwed connection	Raccord à vis	Atornillamiento
	1	1	1				
6	00009033			Haltewinkel	holder	Support	Soporte
	1	1	1				
7	00001159			Mutter	nut	Écrou	Tuerca
	1	1	1				
8	112922			Manometer	Pressure gauge	Manomètre	Manómetro
	1	1	1				
9	MAV-LR08R1/4Zoll			Verschraubung	Screwed connection	Raccord à vis	Atornillamiento
	1	1	1				

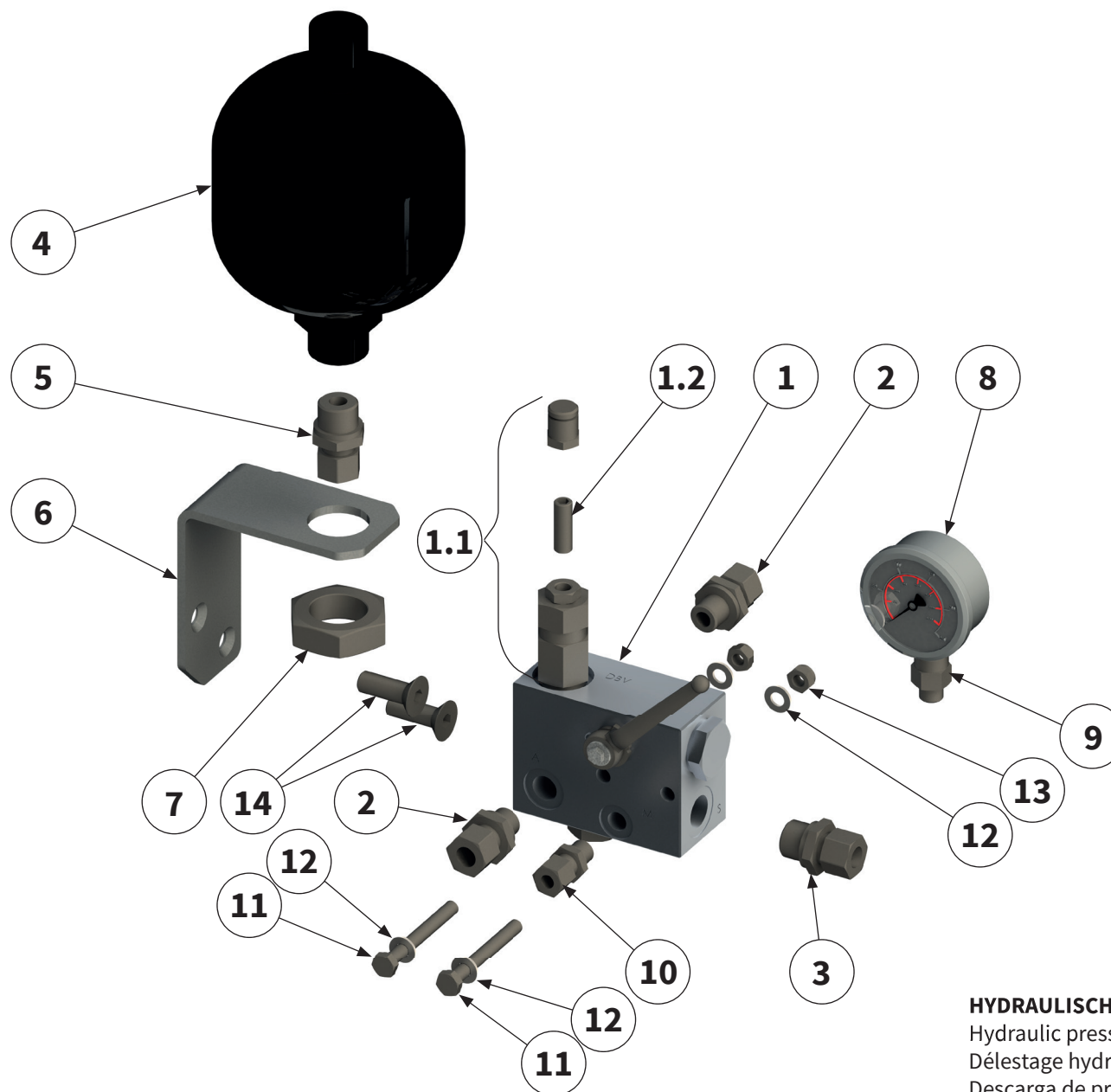

HYDRAULISCHE DRUCKENTLASTUNG MU-SOFA |
 Hydraulic pressure relief MU-SOFA |
 Délestage hydraulique MU-SOFA |
 Descarga de presión hidráulica MU-SOFA |

Pos.-Nr. No. Numéro Número	Ersatzteilnummer Manufacturer part number Numéro de pièce du fabricant Número de pieza del fabricante			DE Bezeichnung	EN Designation	FR Désignation	ES Designación
	Anzahl quantity quantité número						
	MU-C 120	MU-C 140	MU-C 160				
10	GE-08-PLR-1/4			Verschraubung	Screwed connection	Raccord à vis	Atornillamiento
	1	1	1				
11	MU980122			Schraube	bolt	Vis	Tornillo
	2	2	2				
12	MU0099999			Scheibe	washer	Disque	Arandela
	6	6	6				
13	MU0099961			Mutter	nut	Écrou	Tuerca
	4	4	4				
14	MU980134			Schraube	bolt	Vis	Tornillo
	2	2	2				

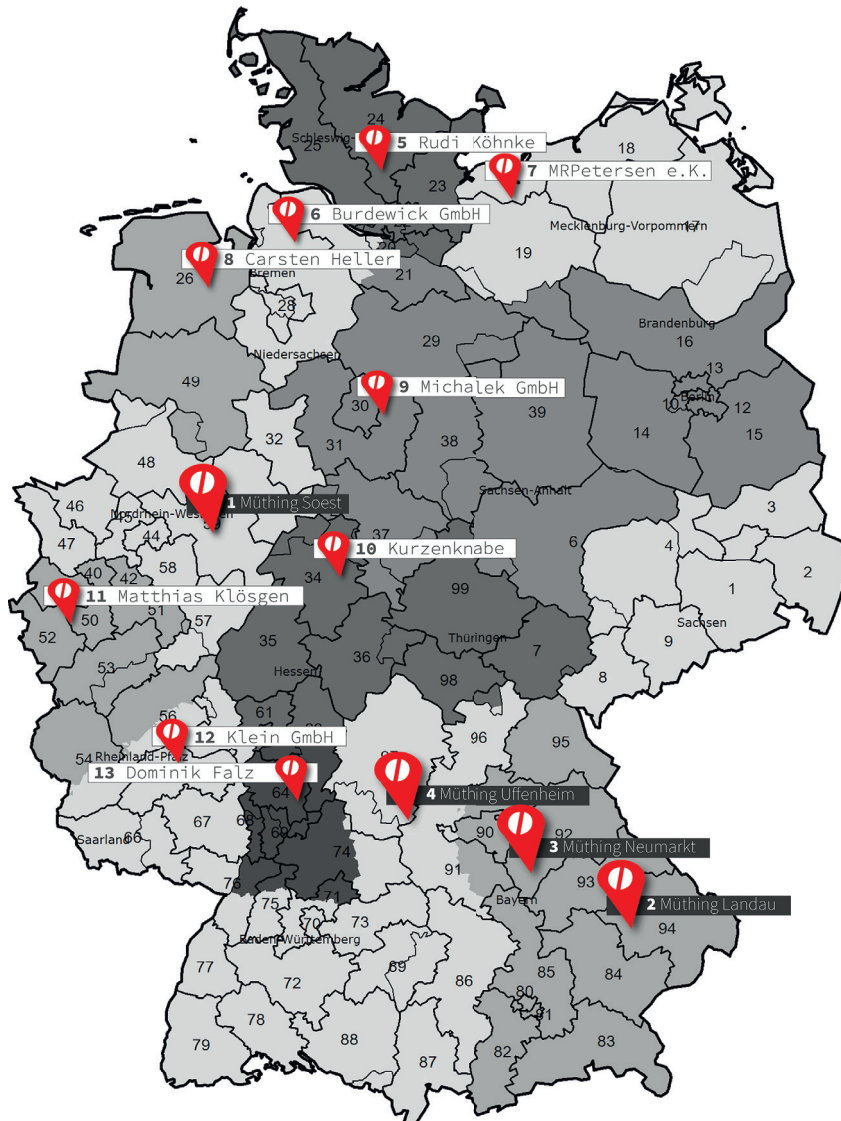

(1) Müthing GmbH & Co. KG Soest

Am Silberg 23
59494 Soest
Tel.: 02921 / 9651 - 0
Fax: 02921 / 73080
E-Mail: et-soest@muething.com

(2) Müthing GmbH & Co. KG Landau

Wiesenweg 6
94405 Landau
Tel.: 09951 / 6908 - 0
Fax: 09951 / 6333
E-Mail: et-landau@muething.com

(3) Müthing GmbH & Co. KG Neumarkt

Hans-Dehn-Str. 7
92318 Neumarkt
Tel.: 09181 / 2976 - 0
Fax: 09181 / 21841
E-Mail: neumarkt@muething.com

(4) Müthing GmbH & Co. KG Uffenheim

Am Brünlein 2
97215 Uffenheim
Tel.: 09842 / 9866 - 0
Fax: 09842 / 9866 - 67
E-Mail: et-uff@muething.com

(5) Rudi Köhnke

Wohldweg 16
24558 Henstedt-Ulzburg
Tel.: 04193 / 91544
Fax: 04193 / 759576
E-Mail: krkoehnke@aol.com

(6) Burdewick GmbH

Mittelstenaher Str. 33
21769 Lamstedt
Tel.: 04773 / 8941 - 0
Fax: 04773 / 8941 - 41
E-Mail: info@burdewick.de

(7) MRPetersen e.K. Werksvertretung

Christiansburger Weg 20
24969 Lindewitt / OT Sillerup
Tel.: 04604 / 9866 - 36
Fax: 04604 / 9866 - 37
E-Mail: rp@mrpetersen.de

(8) Müthing GmbH & Co. KG Soest - Carsten Heller Werksbeauftragter

Tel.: 0160 / 96919245
Fax: 04461 / 759302
E-Mail: c.heller@muething.com

(9) Michalek GmbH

Industriestraße 14
31275 Lehrte
Tel.: 05132 / 2006 - 0
Fax: 05132 / 2006 - 30
E-Mail: info@michalek-ww.de

(10) Kurzenknabe

Obervellmarer Weg 36
34314 Espenau
Tel.: 05673 / 4012
Fax: 05673 / 2495
E-Mail: info@kurzenknabe-gmbh.de

(11) Matthias Klösger

Drovestrasse 104
52372 Kreuzau
Tel.: 02422 / 9019 - 25
Fax: 02422 / 9019 - 26
E-Mail: matthias.kloesger@t-online.de

(12) Klein GmbH

Hauptstraße 2
55627 Weiler / Nahe
Tel.: 06754 / 404
Fax: 06754 / 643
E-Mail: klein-ww-weiler@t-online.de

(13) Dominik Falz

Carl-Benz- Str. 4
64711 Erbach / Odw.
Tel.: 06062 / 1867
Fax: 06062 / 61851
E-Mail: d.falz@muething-mulcher.de

Bei weiteren Fragen zu Technik und Einsatz Ihres Gerätes stehen Ihnen unsere Mitarbeiter oder unsere Vertriebspartner gerne zur Verfügung.

Our employees or sales partners are happy to help should you have any further questions on the technical aspects and use of your implement.

Nos collaborateurs ou nos partenaires commerciaux sont à votre entière disposition pour toutes questions complémentaires relatives aux caractéristiques techniques ou à l'utilisation de votre engin.

Tanto nuestros empleados como los socios comerciales de la marca estamos a su disposición para atender cualquier consulta técnica o sobre piezas que pueda tener respecto a su equipo.

Blank lined page for notes.



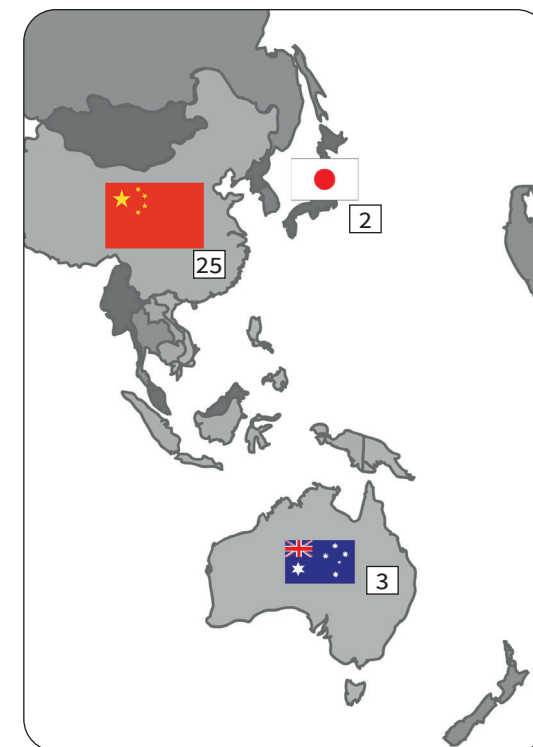

**(1) Prairie Agri Sales Ltd.**

W. Heidebrecht
P.O Box 216
Road 6W , 26028
Lowe Farm, MB R0G 1E0
Tel.: 001-204-746-6994
Fax: 001-204-515-4064
E-Mail: wheidebrecht@prairiegrisaes.ca

**(6) IP Innovations et Paysage**

ZI de Saint Nizier
F - 42190 Charlieu
Tel.: 0033 / 477 605454
Fax: 0033 / 477 606846
E-Mail: info@innovex-gmbh.de

**(11) Oy J-Trading Ab**

Kuriiritie 15
01510 Vantaa
Tel.: 00358 / 207458600
Fax: 00358 / 207458651
E-Mail: info@j-trading.fi

**(16) EZ Agrar e. Gen**

Salzburger Straße 38
4020 Linz
Tel.: 0043 / 732 347266
Fax: 0043 / 732 347260
E-Mail: office@ezagr.ar.at

**(21) Mühthng GmbH & Co. KG Soest**

Am Silberg 23
59494 Soest
Tel.: 02921 / 9651 -0
Fax: 02921 / 73080
E-Mail: et-soest@muething.com

**(2) Agri Direct Co. Ltd.**

Higashimemuro, Memuro-cho,
Kasai-gun
18-7 Kita 1-sen
Hokkaido 082-0004
Tel.: 0081 / 155612777
Fax: 0081 / 155612755
E-Mail: info@agridirect.jp

**(7) GTJ**

Peter Janssen
Way Broek 5
6041PJ Roermond
Tel.: 0031 /615370411
E-Mail: p.janssen@gjtjtrading.nl

**(12) Brøns Group**

Hovedvejen 20
6780 Skærbæk
Tel.: 0045 / 74753112
E-Mail: brons@bronsgroup.com

**(17) Güttler Mezőgazdasági**

Gépgyárto és Szolgá Kft.
Külterület 022/ 35
6800 Hódmezővásárhely
Tel.: 0036 / 62 533690
Fax: 0036 / 62 533691
E-Mail: orsolay.torok@guttler.hu

**(22) Mühthng GmbH & Co. KG Uffenheim**

Am Brunnlein 2
97215 Uffenheim
Tel.: 09842 / 9866 - 0
Fax: 09842 / 9866 -67
E-Mail: et-uff@muething.com

**(3) Southern Cross Mowers PTY Ltd.**

Marcus Cornish
1/29 Mustang Drive, PO Box 454
Rutherford NSW Australia 2320
Tel.: 0061 / 240440313
Fax: 0061 / 249321088
E-Mail: mcornish@sxm.com.au

**(8) Van Dyke Marcel Belgium**

Provinciebaan 71 - 2235 Houtvenne
Tel.: 0032 / 16699156
E-Mail: info@vandyck.be
GÖWEIL BNL PGmbH - Mirfeld
Zur Schmiede 23 - 4770 Amel
E-Mail: office@goeweil.be

**(13) Konekesko Eesti AS**

Pildiküla Rae vald
Porguvälja tee 3a
75308 Harjumaa MK
Tel.: 00372 / 6059100
Fax: 00372 / 6059101
E-Mail: kristjan.nelis@kesko.ee

**(18) Topagri S.r.o.**

Kostalkova 1527
26601 Beroun
Tel.: 00420 / 311 636766
Fax: 00420 / 311621822
E-Mail: topagri@topagri.cz

**(23) EZ Landmaschinen AG**

Bützbergstrasse 70
4912 Aarwangen
Tel.: 0041 / 62 9226801
Fax: 0041 / 62 9230369
E-Mail: info@ezlandmaschinen.ch

**(4) Simon Richard Ltd.**

Crown Tailrig
Simon Richardt
Bonchester Bridge
Hawick TD9 8RA
Tel.: 0044 / 1450860774
Fax: 0044 / 1450860772
E-Mail: mail@simon-richard.co.uk

**(9) Felten Freres et Fils Sarl**

Zone Artisanale
9775 Weicherdange
Tel.: 00352 921612
Fax: 00352 920530
E-Mail: info@felten.lu

**(14) SIA Konekesko Latvija**

Tiraines 15
1058 Riga
Tel.: 00371 / 67064300
Fax: 00371 / 67064301
E-Mail: aivars.metla-rozents@kesko.lv

**(19) Ematech s.r.o**

Piestanska 3/3
95605 Radosina
Tel.: 00421 / 385398119
Fax: 00421 / 385398216
E-Mail: ematech@ematech.sk

**(24) G.I.Antonakis A.E.**

3 xlm Thiva-Mouriki
32200 Thiva
Tel.: 0030 / 2262 025915
Fax: 0030 / 2262 025914
E-Mail: gianton@otenet.gr

**(5) Delgado Delgado e Hijos, S.A.**

C / Sevilla , 23
34004 Palencia
Tel.: 0034 / 979728450
Fax: 0034 / 979710390
E-Mail: recambios@deltacinco.es

**(10) ForSentralen AS**

Einar M. Bardal/ Carl M. Bardal
Bardalsvegen 100
7724 Steinkjer
Tel.: 0047 / 7414-7600
Fax: 0047 / 7414-9399
E-Mail: forsentralen@online.no

**(15) UAB Konekesko**

Vilnius raj.
Moletu g. 13
14262 Didžioji Riese
Tel.: 00370 / 46421752
Fax: 00370 / 46421753
E-Mail: vilnius.sventkauskas@kesko.lt

**(20) NHR Agropartners SRL**

Judet Ilfov
Calea Bucurestilor 247
075100 Otopeni
Tel.: 0040 / 21 3007906
Fax: 0040 / 213521660
E-Mail: office@vait.ro

**(25) Ten Square International Inc. Nanjing**

Rm.402 Bldg.2, Zhongqing Plaza NO.96
Caochangmen St. Nanjing, Jiangsu
210013 China
Tel.: 0086 / 25 86210358
Fax: 0086 / 25 86212081
E-Mail: usoffice@tensquare.com

www.muething.com



Müthing GmbH & Co. KG Soest
Am Silberberg 23
59494 Soest

Tel +49 (0) 2921 96510
Fax +49 (0) 2921 73080
soest@muething.com

Müthing GmbH & Co. KG Uffenheim
Am Brünlein 2
97215 Uffenheim

Tel +49 (0) 9842 98660
Fax +49 (0) 9842 98667
uffenheim@muething.com

WWW.MUETHING.COM